



STANDARD/MODIFIED TAP PERMIT FOR COMMERCIAL STRUCTURES

1. PERMITTED PREMESIS/PERMITTED SIZE(S):

Street address: _____ Monument, CO 80132

Legal Description: Lot # _____, Block # _____, Subdivision _____.

Taps permitted to be installed (circle all that apply): Water Sewer Fire Suppression

Sewer tap size: _____ (Inches) Water tap size: _____(Inches)

Water tap size (Fire Suppression) _____(inches)

Total Drainage Fixture Units (domestic) _____ Total Water Supply Fixture Units (domestic): _____

Water Meter Size (domestic) _____

Water Meter Size (irrigation) _____

2. PERMIT CONTACT INFORMATION:

Name of Prime Contractor

Name of Owner

Mailing Address

Mailing Address

City, State, Zip Code

City, State, Zip Code

3. PERMIT FEES PAID:

Application Deposit (refundable): _____, Equipment Fee: _____,

Processing / Inspection Fee: _____,

Tap Fees: Water: Service Line & Tap Size: _____, Fee: _____,

 Sewer: Drainage Fixture Units: _____, Fee: _____,

Total Fees and Deposit: _____.

4. GENERAL PERMIT TERMS AND CONDITIONS:

- a. Owner agrees to pay the water and sewer monthly fees and abide by the rules, regulations and policies of the District as may be amended from time to time. A copy of these rules and regulations are available for inspection at the District office.
- b. Installation of taps, service lines and associated equipment shall be in accordance with all District rules and regulations and system specifications and shall adhere to and be in compliance with the service line plan as approved by the District.
- c. Owner shall be responsible for calling and scheduling inspections of the tap and service line installations as well as the meter and associated equipment installations prior to covering up any work. Partial inspections may be requested as the work commences. Once all tap, service line, meter and associated service equipment has been installed and has passed inspected by the District (final inspection), the District will install the meter register(s) necessary to read water usage.
- d. If construction is not completed and final inspection by the District is not made within 12-months from the date this permit is issued, the permitted premises will be subject to any increase in tap fees that takes effect prior to the time that final inspection is made. If a tap has not been made within the 12-month period, no tap will be allowed until any applicable increase in tap fees has been paid. Any tap fee prepaid prior to March 15, 1995, is not affected by this provision.
- e. A water hammer arrester and a pressure reducing valve that complies with District system specifications must be installed before each water meter. An approved cross connection control device must be installed after each water meter and at each fire suppression service line entry into the building. The cost of installation, maintenance and testing in accordance with the Districts rules and regulations shall be the responsibility of the property owner.
- f. Commercial meters newly installed are owned and maintained by the District. Owner shall be liable to the District for any damages to or loss of a meter caused by Owner.
- g. Exclusive of the water curb stop box, the water service line from the main to the Owners property line or curb box, whichever is closer to the water main, is owned and maintained by the District. Owner shall be liable to the District for any damages or obstructions to this reach of service line caused by Owner.
- h. The Woodmoor Water and Sanitation District No. 1 is not responsible for any cost of installation, operation or maintenance of any private water service lines or sewer service lines.
- i. The owner is responsible for contacting the District for water/sewer main locates.
- j. After the water tap is completed, the District will charge the minimum monthly water and sewer service fees as well as any other applicable fees. A meter reading will be taken by the District as of occupancy date, and the District will continue to read the meter and provide the occupant this reading on the monthly bill. The District has increasing block rates to discourage excessive water use.
- k. Owner shall be responsible for verifying that a final inspection has been performed by the District prior to any request and subsequent issuance of a certificate of occupancy (CO) or temporary certificate of occupancy (TCO) by the regional building department or building authority having jurisdiction. If a CO/TCO is issued prior to the District conducting a final inspection and the installation of the water meter register(s), no refund of the tap fee deposit will be made and the District may disconnect service.

1. This permit shall transfer ownership upon sale of the property. Water and sewer fees and charges also run with the property rather than the person. The owner understands and agrees that the District will bill the tenant as a matter of courtesy to owner, however, if the tenant does not pay, the owner of the property is responsible for payment of any outstanding bills.

m. Site Specific Provisions:

COMMERCIAL TAP P E R M I T

Approved this _____ day of _____, 20__.

WOODMOOR WATER AND SANITATION DISTRICT NO. 1

By _____
For secretary

This Permit Form is effective the _____ day of _____, 20____ and supersedes all previous permits issued by this District for the premises.



WOODMOOR
Water & Sanitation District No. 1

**Commercial Sewer Service Line Sizing
Application & Forms for New or Modified Service**

Commercial Sewer SERVICE LINE (Tap) Sizing Review Process

Woodmoor Water and Sanitation District (the "District") accepts one method for sizing sewer service lines:

Standard Method

1. The Property Owner (or his assigned representative) shall be responsible for the accuracy of all data calculated and sent to the District for review.
2. The Owner works with an Architect/Professional Engineer to provide the necessary documentation for sewer service line sizing. (One form per building structure)
3. The Owner submits the Architect/Professional Engineer's completed domestic drainage fixture unit counts in accordance with International Plumbing Code (IPC) showing number of drainage fixture units and anticipated peak drainage flows for domestic drainage through the service line and into the sanitary sewer collection system. Estimated peak flows are used for design of tap & service line size. The Owner shall also submit one set of utility service line plans in accordance with the Districts "System Specifications" and one set of the proposed building's architectural Plumbing plans showing the drainage fixtures and piping layouts. Sample forms for drainage fixture unit counts are contained on page 4 of this document.
4. The District will review the proposed sewer service line sizing documents in conjunction with the water meter sizing documents (if applicable). The District will coordinate any comments/revisions with the Owner. Submittal will be reviewed within 21 calendar days.
5. If approved, the District will notify the Owner/design professional that the tap permit is available for pick up upon payment of all permit fees.



Commercial Sewer Service Line & Tap Size Application (New & Modified Service):

All landowners relevant to this application must be included as applicants of this submittal. By signing this application and attaching a completed Statement of Authority, applicant and property owner attests that they are aware of this application and agree to its content.

The Owner/Applicant shall attach the sewer line sizing documentation along with one set of drawings of the proposed plumbing mechanical plans for the structure to the Woodmoor Water and Sanitation District No. 1, (719) 488-2525, at 1845 Woodmoor Drive, Monument, CO 80132.

Sizing sewer service lines shall be based upon Drainage Fixture Units per the current approved version of the International Plumbing Code as adopted by the Pikes Peak Regional Building Department.

Owner/Applicant Name _____
Phone Number _____
Address of Facility _____

Use of Facility _____

Contractor information

The undersigned hereby makes application to Woodmoor Water and Sanitation District No. 1 for approval of sewer service size(s). Applicant has read and understands the application instructions, and certifies that all information contained herein is accurate and true to the best of their knowledge and belief.

Owner/Agent Signature Date

EXAMPLE DRAINAGE FIXTURE UNIT WORKSHEET

Fixture Type	Number of Fixture units			Total Number of Fixture Units	Total d.f.u.
	Existing	+	Proposed		
(Common Fixtures listed below)					
		+		=	X
Automatic Cloths Washer, Commercial		+		=	X
Automatic Cloths Washer, Residential		+		=	X
Water Closet, 1.6 g.p.f.		+		=	X
Water Closet, >1.6 g.p.f.		+		=	X
Bathtub		+		=	X
Bidget		+		=	X
Combination Sink & Tray		+		=	X
Dental Lavatory		+		=	X
Dental Unit or Cuspidor		+		=	X
Dishwashing Machine, Domestic		+		=	X
Drinking Fountain		+		=	X
Emergency Floor Drain		+		=	X
Floor Drain		+		=	X
Floor Sink		+		=	X
Kitchen Sink, Domestic		+		=	X
Kitchen Sink, Domestic w/grinder		+		=	X
Laundry Tray (1 or 2 compartment)		+		=	X
Lavatory		+		=	X
Shower:					
	5.7 gpm or less	+		=	X
	>5.7<12.3 gpm	+		=	X
	>12.3<25.8 gpm	+		=	X
	>25.8<55.6 gpm	+		=	X
Service Sink		+		=	X
Sink		+		=	X
Urinal		+		=	X
Urinal, 1 gpf		+		=	X
Urinal, non-water supplied		+		=	X
Wash Sink		+		=	X
Water Closet		+		=	X
Other		+		=	X
Total Drainage Fixture Units (domestic) =					
Max Flow Rate (gpm) =					
Min Flow Rate (gpm) =					
Booster Pumps:					
Will Sewer Ejector Pump(s) be used?		Y	N		
If yes, please provide peak pumping system capacity (gpm) and information on any drainage fixture Units that will bypass the booster pump(s)					
Any process or special drainage use? (not included in above fixtures)		Y	N	Type	
if yes, type and peak gpm demand?					

Notes:

1) All listed fixtures from IPC Table 709.1, for fixtures not listed, refer to IPC.

I affirm that the information given is accurate and acknowledge that approval of meter size and maximum water capacity is based solely on the information provided above.

Owner/Agent: _____

Date: _____

Architect/Professional Engineer: _____

Date: _____

Commercial Sewer Service Line Sizing Form Peak Flow Summary Sheet

Flow:

Domestic Sewer Flow (D): Maximum Drainage Fixture Units _____
Peak Flow Rate: _____ (gpm)

*Domestic Peak Flow Rate based on d.f.u. total of _____ (from page 4) plus your reported Process Water and/or
Booster Pump Capacity totaling _____ gpm.*

Service Line & Tap Size Requested: _____ Inch

Status: Prosed New Proposed Modification

Additional Customer Comments:

Owner/Agent: _____ Date: _____

This sheet for District Internal use only:

Application received by _____ Date _____

New or Modified Service: New Modified

Existing:

Size of Tap & Service Line _____ Slope: _____ Material: _____

Total Drainage Fixture Units: _____

New or as Modified:

Size of Tap & Service Line _____ Slope: _____ Material: _____

Total Drainage Fixture Units: _____

Comments:



WOODMOOR
Water & Sanitation District No. 1

**Commercial Water Meter & Service Line Sizing
Application & Forms for New or Modified Service**

Commercial Water SERVICE LINE (Tap) Sizing Review Process

Woodmoor Water and Sanitation District (the “District”) accepts one method for **sizing water service lines**:

Standard Method

1. The Property Owner (or his assigned representative) shall be responsible for the accuracy of all data calculated and sent to the District for review.
2. The Owner works with the Architect/Professional Engineer to provide the necessary documentation for water service line sizing. (One form per building structure)
3. The Owner submits the Architect/Professional Engineer’s completed irrigation flow and domestic fixture unit counts in accordance with International Plumbing Code (IPC) showing number of fixture units and anticipated peak demands for irrigation and internal domestic water usage. Combined estimated peak flows (irrigation plus domestic) are used for tap & service line size selection per table 1 or 2 on page 8. The Owner shall also submit one set of utility service line plans in accordance with the Districts “System Specifications” and one set of the proposed building’s architectural Plumbing and Irrigation plans showing the water fixtures and piping layouts. Sample forms for fixture unit counts and irrigation system flows are contained in pages 6 and 7 of this document.
4. The District will review the proposed water service line sizing documents in conjunction with the water meter sizing documents. The District will coordinate any comments/revisions with the Owner. Submittal will be reviewed within 21 calendar days.
5. If approved, the District will notify the Owner that the tap permit is available for pick up upon payment of all permit fees.

Commercial Water METER Sizing Review Process

Woodmoor Water and Sanitation District (the “District”) accepts two methods for sizing water meters:

Standard Method

1. The Property Owner (or his assigned representative) shall be responsible for the accuracy of all data calculated and sent to the District for review.
2. The Owner works with the Architect/Professional Engineer to provide the necessary documentation for water meter sizing. (One form per building structure)
3. The Owner submits the Architect/Professional Engineer’s completed irrigation flow and domestic fixture unit counts in accordance with International Plumbing Code (IPC) showing number of fixture units and anticipated minimum and maximum demands for irrigation and internal domestic water usage. Meters for irrigation and internal domestic usage shall be separate and estimated peak flows are used for meter size selection per table 3 on page 7. The Owner shall also submit one set of utility service line plans in accordance with the Districts “System Specifications” and one set of the proposed building’s architectural Plumbing and Irrigation plans showing the water fixtures and piping layouts. Sample forms for fixture unit counts and irrigation system flows are contained in pages 5 and 6 of this document.
5. The District will review the proposed water meter sizing documents in conjunction with the service line sizing documents. The District will coordinate any comments/revisions with the Owner. Submittal will be reviewed within 21 calendar days.
6. If approved, the District will notify the Owner that the tap permit is available for pick up upon payment of all permit fees.
7. The Owner/Applicant is responsible for the cost of the water meter and related equipment.

Alternate Method

1. The Property Owner (or his assigned representative) shall be responsible for the accuracy of all data calculated and sent to the District for review.
2. An alternate engineered design for water meters may be submitted to the District, for consideration.
3. A registered design professional (architect or engineer) can submit sufficient technical data to substantiate an alternate design for water meter sizing. This data shall include, but not limited to, construction documents and calculations, to support the proposed alternate design of the water meter, for review and approval by the District. If a diversity factor is used in calculating the meter and service line size, then the engineer shall submit documentation justifying the diversity factor criteria.
4. The District will review the proposed water meter sizing documents. The District will coordinate any comments/revisions with the registered design professional. Submittal will be reviewed within 21 calendar days. If the alternative engineered design is not approved, a District representative shall notify the designer and request that the standard method be used.
4. If approved, the District will notify the Owner that the tap permit is available for pick up upon payment of all permit fees.
5. The Owner/Applicant is responsible for the cost of the water meter and related equipment.



Commercial Water Service Line, Tap & Meter Size Application (New & Modified Service):

All landowners relevant to this application must be included as applicants of this submittal. By signing this application and attaching a completed Statement of Authority, applicant and property owner attests that they are aware of this application and agree to its content.

The Owner/Applicant shall attach the water meter sizing documentation along with one set of drawings of the proposed water/plumbing mechanical plans for the structure to the Woodmoor Water and Sanitation District No. 1, (719) 488-2525, at 1845 Woodmoor Drive, Monument, CO 80132.

Sizing water meters shall be based upon Water Supply Fixture Units per the current approved version of the International Plumbing Code as adopted by the Pikes Peak Regional Building Department.

Owner/Applicant Name _____

Phone Number _____

Address of Facility _____

Legal Description Lot_____, Block_____, Subdivision_____, Filing____

Name of Prime Contractor (if known) _____

Address _____

Phone Number _____

Use of Facility _____

(restaurant, retail, school, office, etc.)

(Denote Answer)

Domestic Use Only: Y N

Irrigation Use Only: Y N

Combined Domestic/Irrigation: Y N

The undersigned hereby makes application to Woodmoor Water and Sanitation District No. 1 for approval of new or modified water tap and service size and meter size(s) requested per the attached documents. Applicant has read and understands the application instructions, and certifies that all information contained herein is accurate and true to the best of their knowledge and belief.

Owner/Applicant Signature

Date



Commercial Irrigation Demand Worksheet

Please choose method

Actual Demand Method (AD)

Design Criteria Method (DC)*

Example (AD)

(AD) Example illustrates a 3-zone system with zones A and B running simultaneously and C independently. To determine peak GPM: zone A + B operating together yields demand of 40 GPM (30 + 10); zone C yields demand of 30 GPM. Meter is sized to largest demand of 40 GPM for system. Appropriate meter size is 1-inch.

Zone	# Heads	GPM per Head	Total GPM per Zone
A	30	1	30
B	20	0.5	10
C	20	1.5	30
Totals	70		70

Example: Zone A + Zone B + Zone ____ = 30 GPM + 10 GPM + ____ GPM = 40 GPM Peak Irrigation System Demand

For AD Method, please provide requested information in table below

For DC Method, enter Value for maximum flow rate in box below

Zone	# Heads	GPM per Head	Total GPM per Zone

Determine maximum flow rate (GPM) by identifying which zones will be operating together ~or~ enter Design Criteria maximum flow rate (GPM)

Zone ____ + Zone ____ + Zone ____ = ____ GPM + ____ GPM + ____ GPM = _____ GPM Peak Irrigation Demand

AD **DC ***

** By selecting the Design Criteria Method (DC) for Irrigation Demand reporting, Owner/Applicant agrees to have empowered the Applicant (if other) to submit the information on their behalf and to the accuracy of the irrigation peak demand value reported herein. The DC peak demand value will be used in lieu of Approved Final Irrigation Plan submittal for the purposes of this form.*

Determine minimum flow rate (GPM) by identifying which zones will be operating together.

Zone ____ + Zone ____ + Zone ____ = ____ GPM + ____ GPM + ____ GPM = _____ GPM Min. Irrigation Demand

I affirm that the information given is accurate and acknowledge that approval of meter size and maximum water capacity is based solely on the information provided above, and such determination is at the sole discretion of Colorado Springs Utilities.

Owner/Applicant: _____ Date: _____

Architect/Professional Engineer: _____ Date: _____

EXAMPLE WATER SUPPLY FIXTURE UNIT WORKSHEET

Fixture Type (Common Fixtures Listed below)	Occupancy	Control Type	Number of Fixtures		=	Total Number of Fixtures	x	Hot + Cold IPC Load Value	=	Total w.s.f.u.	
			Existing	+ Proposed							
			+	=		x	=				
Bathroom Group	Private	Flush Tank	+	=		x	=				
Bathroom Group	Private	Flush Valve	+	=		x	=				
Bathtub	Private	Faucet	+	=		x	=				
Bathtub	Public	Faucet	+	=		x	=				
Bidjet	Private	Faucet	+	=		x	=				
Combined Fixture	Private	Faucet	+	=		x	=				
Dishwashing Machine	Private	Automatic	+	=		x	=				
Drinking Fountain	Offices, etc.	3/8" valve	+	=		x	=				
Kitchen Sink	Private	Faucet	+	=		x	=				
Kitchen Sink	Hotel, Restaurant	Faucet	+	=		x	=				
Laundry Trays (1 to 3)	Private	Faucet	+	=		x	=				
Lavatory	Private	Faucet	+	=		x	=				
Lavatory	Public	Faucet	+	=		x	=				
Service Sink	Offices, etc.	Faucet	+	=		x	=				
Shower Head	Public	Mixing Valve	+	=		x	=				
Shower Head	Private	Mixing Valve	+	=		x	=				
Urinal	Public	1" Flush Valve	+	=		x	=				
Urinal	Public	3/4" Flush Valve	+	=		x	=				
Urinal	Public	Flush Tank	+	=		x	=				
Washing Maching (8 lb.)	Private	Automatic	+	=		x	=				
Washing Maching (8 lb.)	Public	Automatic	+	=		x	=				
Washing Maching (15 lb.)	Public	Automatic	+	=		x	=				
water closet	Private	Flush Valve	+	=		x	=				
water closet	Private	Flush Tank	+	=		x	=				
water closet	Public	Flush Valve	+	=		x	=				
water closet	Public or Private	Flush Tank	+	=		x	=				
Other			+	=		x	=				
Other			+	=		x	=				
Other			+	=		x	=				
Other			+	=		x	=				
Other			+	=		x	=				
Total Water Supply Fixture Units (domestic) =											
Max Flow Rate (gpm) =											
Min Flow Rate (gpm) =											
Booster Pumps:						Max Capacity (gpm)	Min Capacity (gpm)				
Will Booster Pump(s) be used for the domestic system?						Y	N				
If yes, please provide peak pumping system capacity (gpm) and information on any water fixtures that will bypass the booster pump(s)											
Any process water or special water use? (not included in above fixtures)						Y	N	Type	Max Capacity (gpm)	Min Capacity (gpm)	
if yes, type and peak gpm demand?											

Notes:

1) All listed fixture values from IPC Table 103.3(2), for fixtures not listed, loads should be assumed by comparing the fixture to one listed using water in similar quantities and at similar rates. If gpm demand is known use IPC Table 103.3(3).

I affirm that the information given is accurate and acknowledge that approval of meter size and maximum water capacity is based solely on the information provided above.

Owner/Agent: _____

Date: _____

Architect/Professional Engineer: _____

Date: _____

WATER METER, TAP & SERVICE SIZE SELECTION TABLES

Table 1 - Tap & Service Size Selection Table **Maximum Allowable Fixture Units for Various Lengths of Service Line**

Service Length (Ft.)	50	100	150	200	250	300	350	400	450	500	550	600	650
3/4"	35	22	17	14	12	11	10	9	9	8	8	7	7
1"	96	57	43	35	30	27	24	22	21	19	18	17	16
1-1/2"	403	230	167	133	112	98	87	79	72	67	62	59	55
2"	760	760	577	457	382	329	291	261	238	219	203	189	177
2-1/2"	1322	1322	1116	892	748	647	571	513	466	428	396	369	346
3"	1854	1854	1854	1854	1632	1426	1269	1146	1047	964	895	836	784
4"	3382	3382	3382	3382	3382	3382	3382	3134	2872	2660	2484	2334	2204
6"	17214	17214	17214	17214	17214	17214	17214	17214	17214	17214	17214	17214	17214

Table 2 - Tap & Service Size Selection Table **Maximum Allowable Water Flow Rate (gpm) for Various Lengths of Service Line**

Service Length (Ft.)	50	100	150	200	250	300	350	400	450	500	550	600	650
3/4"	19	13	11	9	8	7	7	6	6	6	5	5	5
1"	41	29	23	20	17	16	14	13	13	12	11	11	10
1-1/2"	111	76	61	52	47	42	39	36	34	32	30	29	28
2"	170	170	141	121	107	97	89	83	78	74	70	67	64
2-1/2"	250	250	222	190	168	152	140	130	122	116	110	105	100
3"	320	320	320	320	291	264	243	226	212	200	190	181	174
4"	500	500	500	500	500	500	500	500	444	420	399	380	364
6"	1000	1000	1000	1000	1000	1000	1000	1000	1000	1000	1000	1000	1000

Notes (table 1 and table 2):

- (1) Max. Elevational Difference between main and meter is 20 feet
- (2) Tables incorporate friction losses from main to the meter only
- (3) Tables do not account for length or friction losses nor elevational head loss associated with internal building plumbing
- (4) Tables based on minimum available static pressure at the main of 60 psi.

Table 3 **Water Meter Selection Table**

Range of Flow	Min. (gpm)	Max. (gpm)
Disc Meters		
3/4"	0.125	25
1"	0.500	70
1-1/2"	1.250	120
2"	1.500	170
Compound Meters		
2"	0.5	200
3"	0.5	450
4"	0.75	1000
6"	0.75	2000

Commercial Water Meter & Service Line Sizing Form Demand Summary Sheet

Flow:

Irrigation Flow (I): Maximum Flow Rate: _____ (gpm)

Minimum Flow Rate: _____ (gpm)

Requested Meter Size for Irrigation = _____ Inch (from Table 3 on page 7)

Domestic Flow (D): Maximum water supply fixture units _____

Maximum Flow Rate: _____ (gpm)

Minimum Flow Rate: _____ (gpm)

Requested Meter Size for Domestic = _____ Inch (use table 3 on page 7)

*Domestic Max Flow Rate based on w.s.f.u. total of _____ (from page 6) plus your reported Process Water and/or
Booster Pump Capacity totaling _____ gpm.*

Total Irrigation plus Domestic: Maximum Flow Rate: I + D = _____ (gpm)

Service Line & Tap Size Requested: _____ Inch (use table 1 or 2 on page 7)

Length of Service Line (Main to Meter): _____ Feet

Status: Proposed New Proposed Modification

Note: Unless separate taps are to be purchased for irrigation and domestic services, service line & tap size shall be based on maximum combined flow (i.e. max irrigation flow + Max Domestic Flow). Meter sizes may be dissimilar between irrigation, domestic and water tap & service size, however in no event shall any meter size be greater than the tap & service line size.

Additional Customer Comments:

Owner/Agent: _____ Date: _____

This sheet for District Internal use only:

Application received by _____ Date _____

New or Modified Service: New Modified

Existing:

Size of meter Irrigation _____ Type: Disk Compound

Size of meter Domestic _____ Type: Disk Compound

Size of tap & service line _____ Total Water Supply Fixture Units: _____

New or as Modified:

Size of meter Irrigation _____ Type: Disk Compound

Size of meter Domestic _____ Type: Disk Compound

Size of tap & service line _____ Total Water Supply Fixture Units: _____

Comments:

WATER AND SEWER SERVICE LINE MATERIAL, METERS AND MINIMUM REQUIRED EQUIPMENT

PART 1 GENERAL

1.1 SUMMARY

- A. Section Includes
 - 1. Piping material, tapping saddles, corporation stops, curb stops & boxes, water and sewer service line material, fittings, anti-hammer devices, meters, ball valves, check valves and associated water and sewer service line accessories.

1.2 REFERENCES

- A. Referenced Standards
 - 1. ANSI B31.9-Building Service Piping
 - 2. NSF 61-Drinking Water System Components-Health Effects
 - 3. ASTM D1784 – Rigid Poly (Vinyl Chloride) (PVC) Compounds and Chlorinated Poly (Vinyl Chloride) (CPVC) Compounds
 - 4. ASTM D2321 – Practice for Underground Installation of Flexible Thermoplastic Sewer Pipe
 - 5. ASTM D3034 – TYPE PSM Poly (Vinyl Chloride) (PVC) Sewer Pipe and Fittings
 - 6. ASTM D3212 – Joints for Drain and Sewer Plastic Pipes Using Flexible Elastomeric Seals
 - 7. ASTM F477 – Elastomeric Seals (Gaskets) for Joining Plastic Pipe
 - 8. AWWA C509-Resilient Seated Gate Valves 3 in through 12 in NPS, for Water and Sewage Systems
 - 9. AWWA C515-Reduced-Wall, Resilient-Seated Gate Valves for Water Supply Service
 - 10. AWWA C504-Rubber Seated Butterfly Valves

1.3 ACTION SUBMITTALS

- A. For items specified as “or equal”, owner/contractor shall determine if the product being installed meets the minimum requirements specified herein and no product submittals are required by the District.
- B. For products without an “or equal” statement or that are listed herein with specific model or manufacturer’s numbers, only those products specifically listed shall be installed. Owner/contractor may submit product data on alternate materials desired that illustrates the product desired to be used meets or exceeds the specified products attributes in all respects for approval or rejection by the District prior to installation.

1.4 QUALITY ASSURANCE

- A. Perform Work in accordance with all applicable codes and regulations.

1.5 REGULATORY REQUIREMENTS

- A. Conform to all municipal codes and ordinances, laws and regulations of the State.
- B. In case of apparent conflict, state and local requirements govern over these specifications.
- C. In absence of state and local regulations, International Plumbing Code applies.

1.6 DELIVERY, STORAGE, AND HANDLING

- A. Deliver, store, protect and handle products according to manufacturer's recommendations.

PART 2 PRODUCTS (WATER SERVICE LINES)**2.1 SERVICE LINE PIPING & FITTINGS (2" AND SMALLER)**

- A. Manufacturer and Product
 - 1. Type "K" soft copper, coils or standard 10 and 20 foot lengths, Mueller Streamline Co, or equal. Copper or lead free brass fittings in accordance with NSF 61.

2.2 SERVICE LINE PIPING & FITTINGS (2-1/2" AND 3")

- A. Manufacturer and Product
 - 1. Type "K" soft copper, Mueller Streamline Co, or equal. Copper or lead free brass fittings in accordance with NSF 61.
 - 2. PVC pipe, gasketed bell and spigot, ASTM D2241, IPS size, SDR 21 with 200 psi working pressure rating, JM Eagle "IPS Pressure" pipe or equal. Ductile Iron gasketed push on fittings (i.e. PVC ends), IPS size, ASTM A536, AWWA C153, 250 psi pressure rated, Harrington Corporation or equal. All fittings and valves must be restrained using ductile iron fitting restraints, Harrington Corporation Ductile Iron IPS restraints or equal.
 - 3. Ductile Iron or PVC pipe material and fittings in accordance with section 33 11 00 Water Utility Distribution Piping.

2.3 SERVICE LINE PIPING & FITTINGS (4" AND LARGER)

- A. Manufacturer and Product
 - 1. Ductile Iron or PVC pipe material and fittings in accordance with section 33 11 00 Water Utility Distribution Piping.

2.4 GATE VALVES (2" THROUGH 12")

- A. Manufacturers:
 - 1. American AVK – Series 45 or 65
 - 2. American Flow Control – Series 2500
 - 3. Or equal.
- B. AWWA C515 or AWWA C509, minimum working pressure of 250 psi., ductile iron body, lead free, stainless steel stem, two O-ring stem seals, non-rising stem with square nut, single wedge fully encapsulated with EPDM rubber, resilient seat, Mechanical Joint Ends or push on/PVC joint ends for IPS pipe or ends per plan, control rod, and extension box.
- C. Rotation: Open left (counter clockwise) with the word "OPEN" and an arrow indicating the direction to open cast on valve body.

2.5 ISOLATION VALVES (BALL)

- A. Manufacturers
 - 1. Nibco
 - 2. Apollo
 - 3. Or equal
- B. Description
 - 1. For use on 4 inch and smaller non buried piping.
 - 2. 300 lbs minimum working pressure rating.
 - 3. Full port, lead free, certified to NSF 61

2.6 ISOLATION VALVES (BUTTERFLY – OPEN ACCESS)

- A. Manufacturers
 - 1. Nibco
 - 2. Apollo
 - 3. Or equal
- B. Description
 - 1. For use as isolation valves on 3 inch and larger non buried piping.
 - 2. 200 lbs minimum working pressure rating.
 - 3. Lead free, certified to NSF 61

2.7 TAPPING SADDLES

- A. Manufacturers and Products
 - 1. 2" and smaller - Romac #202NS, Smith Blair #317
 - 2. 2-1/2" – IPS threads, Romac #202NS or ductile iron mechanical joint tee with 2-1/2" tapped threads on branch side, see section 33 11 00 Water Utility Distribution Piping for mechanical joint fittings

3. 3" and larger – Ductile iron mechanical joint tee in lieu of tapping saddle, see section 33 12 00 Water Utility Distribution equipment
- B. Description
1. Ductile iron body with nylon or fusion bonded epoxy coating.
 2. AWWA tapered threads
 3. Double 304 stainless steel straps, bolts, and nuts.
 4. Rubber seating gasket.
 5. 250 psi minimum pressure rating.
- C. No direct taps.

2.8 CORPORATION STOPS

- A. Manufacturer and Products (2" and smaller)
1. Ford ball corporation valve, AWWA taper inlet X Flare, ford quick joint compression or pack outlet, 300 psi. working pressure, model FB600-X-XX
 2. Mueller 300 ball corporation valve, AWWA taper X Flare, Mueller 110 compression or pack outlet, 300 psi. working pressure
 3. Or accepted substitution.

2.9 CURB STOPS

- A. Manufacturers and Products (2" and smaller)
1. Ford "B" Series Ball Curb Valve (Non Minneapolis style), Flare inlet X Flare, ford quick joint compression or pack outlet 300 psi. working pressure
 2. Mueller 300 Ball Curb Valve (Non Minneapolis style), Flare inlet X flare Mueller 110 compression or pack outlet, 300 psi. working pressure
 3. Or accepted substitution.

2.10 CURB STOP BOXES (2" AND SMALLER CURB VALVES)

- A. Manufacturers and Products
1. Tyler Union 6500 series, ¾" through 1 ½" curb valves: Arched style base, cast iron sections, slip or screw type extensions, with asphalt bituminous coating, 27/32" standard lid with pentagon head plug. For curb stop valves 2" in size, use "enlarged" box base.
 2. Or accepted substitution.

2.11 CURB STOP BOXES (2-1/2" AND LARGER GATE VALVES)

- A. Manufacturers and Products
1. Tyler Union 6855 Series # 6 Base
- B. Description

1. Slip-type.
2. Cast iron box, base, extensions, and lid.
3. Minimum inside diameter 5 inches.
4. Minimum wall thickness 3/16 inch.
5. All parts coated by dipping in asphalt varnish.
6. Minimum lid depth 3”.
7. Lid is drop type and marked with “WATER”.

2.12 WATER METERS

- A. Manufacturers and Products
 1. Badger Meter
- B. Supplied by District, size shall be as indicated on tap permit.

2.13 ANTI-HAMMER ARRESTORS

- A. Manufacturers and Products
 1. Precision Plumbing Products, Inc.
 2. Watts
 3. Or equal
- B. Metallic body, NSF 61 certification with 0-200 psi static pressure rating.
- C. Size and surge pressure rating: Per manufacturer’s recommendations for specific pressure and flow application

2.14 BACKFLOW PREVENTION DEVICES

- A. Manufacturers and Products
 1. Watts
 2. Febco
 3. Or equal
- B. ¾” Residential Configurations
 1. Copper or lead free brass
 2. Two positive seating dual check modules
 3. Test cocks not required
 4. 150 psi. minimum working pressure rating
 5. One (1) supplied by District
 6. Larger than ¾” residential application– See non health hazard configurations below
- C. Non-Health Hazard Configurations
 1. Copper or lead free brass
 2. AWWA C510
 3. Two positive seating check modules

4. Minimum of three test cocks
 5. 150 psi. minimum working pressure rating
 6. Size: per tap permit
 7. Commercial application – supplied by Owner
- D. Health Hazard/Potential Health Hazard Configurations
1. Copper or lead free brass
 2. AWWA C511
 3. Two positive seating check modules with internal pressure differential relief valve
 4. Minimum of three test cocks
 5. 150 psi. minimum working pressure rating
 6. Size: per tap permit
 7. Commercial application – supplied by Owner

2.15 PRESSURE REDUCING VALVES

- A. Manufacturers and Products
1. Wilkins
 2. Watts
 3. Or equal
- B. Metallic body, NSF 61 certification
1. Lead free
 2. 200 psi. minimum upstream working pressure rating
 3. Size: per tap permit
 4. Adjustable pressure range downstream : 0 psi. minimum to 75 psi. maximum. or if plumbing code requires more stringent standards, per plumbing code.

PART 3 PRODUCTS (SEWER SERVICE LINES)

3.1 SERVICE LINE PIPING & FITTINGS

- A. Products
1. Cast Iron Soil Pipe, ASTM A74, extra heavy or service type, bell and spigot or plain end.
 2. Cast Iron Soil Pipe Fitting – ASTM C564 or CISPI Standard 310
 3. Plastic Pipe and fittings – ASTM D3034, type PSM, Poly Vinyl Chloride (PVC) material, bell and spigot or glue joint style, SDR 35, Schedule 40 or 80

3.2 ACCESSORIES

- A. Tracer Wire
1. Material: #12 solid copper THHN, insulated for direct bury installation

2. Connections at intersections: Copper connector type Burndy No. YC 6 or equal.
 3. Splices at end to end connections: Copper connector type Dossert No. DPC 2, Homac No. C6
 4. Or accepted substitution.
- B. Sanitary Sewer Service Connection
1. "In Line" Wye
 - a. Wye fitting with gasketed joint per Section 33 31 00.
 - b. Schedule
 - 1) For use when installing proposed service line connections to proposed mains. (New Construction)
 2. Saddle Tap
 - a. Manufacturer
 - 1) Geneco
 - 2) Or Accepted Substitution
 - b. Product
 - 1) Sealtite Multi Range Sewer Saddle
 - 2) Configuration: Wye or Tee
 - 3) Model:
 - a) Wye: Type E
 - b) Tee: Type U
 - 4) Base: ASTM A-48 Class 30 Cast Iron dip-coated in water-based bituminous coating
 - 5) Gasket: O-Ring ASTM C-367-77 Tubular Polyisoprene
 - 6) PVC Adapter: ASTM D-3034 SDR-35 gasketed bell cemented to cast iron base with two-part urethane adhesive
 - 7) Strap: One 24 gauge 2.5 inch wide Type 304 Stainless Steel
 - 8) Strap Pins: 0.75 inch diameter Type 303 Stainless Steel
 - 9) T-Bolts: 0.375 inch diameter-16 Type 304 Stainless Steel
 - 10) Nuts and Washers: Type 18-8 Stainless Steel
 - c. Schedule
 - 1) For use when connecting to existing mains.

PART 4 EXECUTION

4.1 INSTALLATION

- A. Install all components per manufacturers recommendations.
- B. Install 1-1/2" plastic pipe insert, minimum 5 feet in length, into curb stop valve cans, centered on curb stop valve.
- C. For buried underground water service lines utilizing type K soft copper, use brass compression or flare fittings to connect/couple joints, no sweating, soldering or brazed connection permitted underground.

- D. For interior or non-buried copper, soldering, brazing and sweating of copper fittings is permitted in accordance with the local plumbing code.
- E. No backflow prevention device shall be installed in such a configuration that would allow for submergence of the device (i.e. non-draining underground vaults, non-draining basements below grade, etc.). All backflow prevention devices shall be installed at locations where the area in and around the installed device is free draining.

4.2 FIELD QUALITY CONTROL

- A. Service lines from (and including) the curb stop valve/service line shut off valve to the building are the property of the lot owner. Field quality control shall be as provided/mandated by International Plumbing Code or Owner. The District performs inspections on service lines and equipment only to verify location, proper configuration of mandatory components, size of service lines and associated appurtenances. The District does not assume any responsibility or liability for product or installation quality, integrity or longevity of private system components. Manufactures and products for private system improvements and components listed herein are listed in general and/or generic format with minimum attributes that must be complied with.
- B. Service lines from the water main up to (but not including) the curb stop valve to the property are installed at the expense of owner but are owned and maintained by the District. Field quality control shall be as provided/mandated by International Plumbing Code or the District. The District performs inspections on this portion of service lines and equipment to verify location, material, proper configuration and installation of equipment and associated appurtenances. Products in this reach of service line(s) are specifically listed by manufacturer's part number and shall be used unless a substitute item is otherwise approved (in writing) by the District,

END OF SECTION

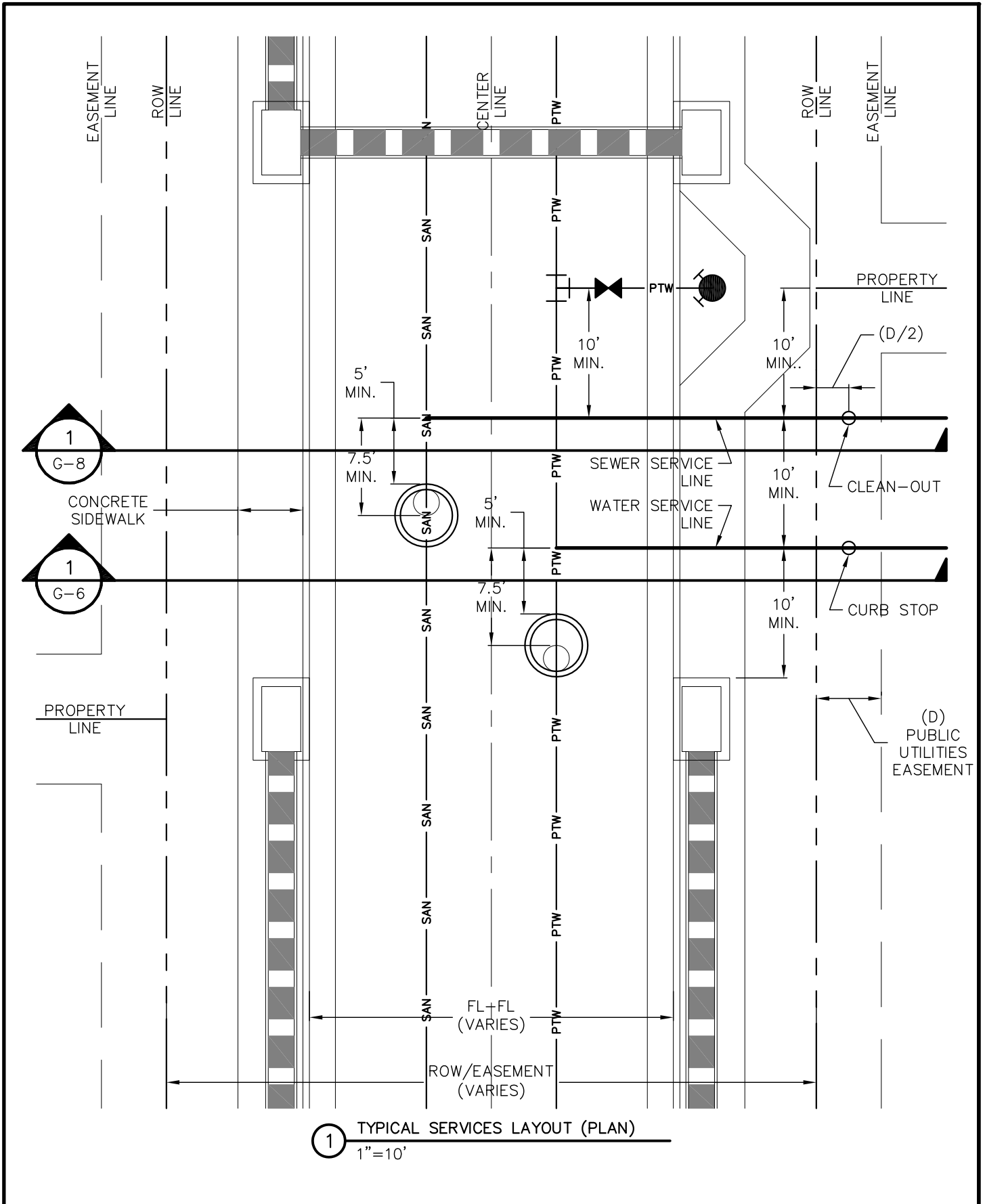

1 TYPICAL SERVICES LAYOUT (PLAN)
1"=10'

	TYPICAL SERVICES LAYOUT (PLAN)	G-5
	GENERAL	-
	THIS CONSTRUCTION DETAIL SHOWS GENERAL CONFORMANCE TO SYSTEM SPECIFICATIONS AND MAY NEED TO BE ADJUSTED FOR SPECIFIC APPLICATIONS.	MAY 13, 2014

REFER TO WATER & SEWER SERVICE LINE EQUIPMENT SPECIFICATIONS FOR SUPPLEMENTAL INFORMATION
(APP C OF THE SYSTEM SPECIFICATIONS)

GENERAL NOTES:

- PROVIDE METAL T-POST AT CURB STOP WHEN CONSTRUCTION OF STUB-OUT TO LOT IS COMPLETE.
T-POST MAY BE REMOVED AFTER CONNECTION TO SERVICE STUB.

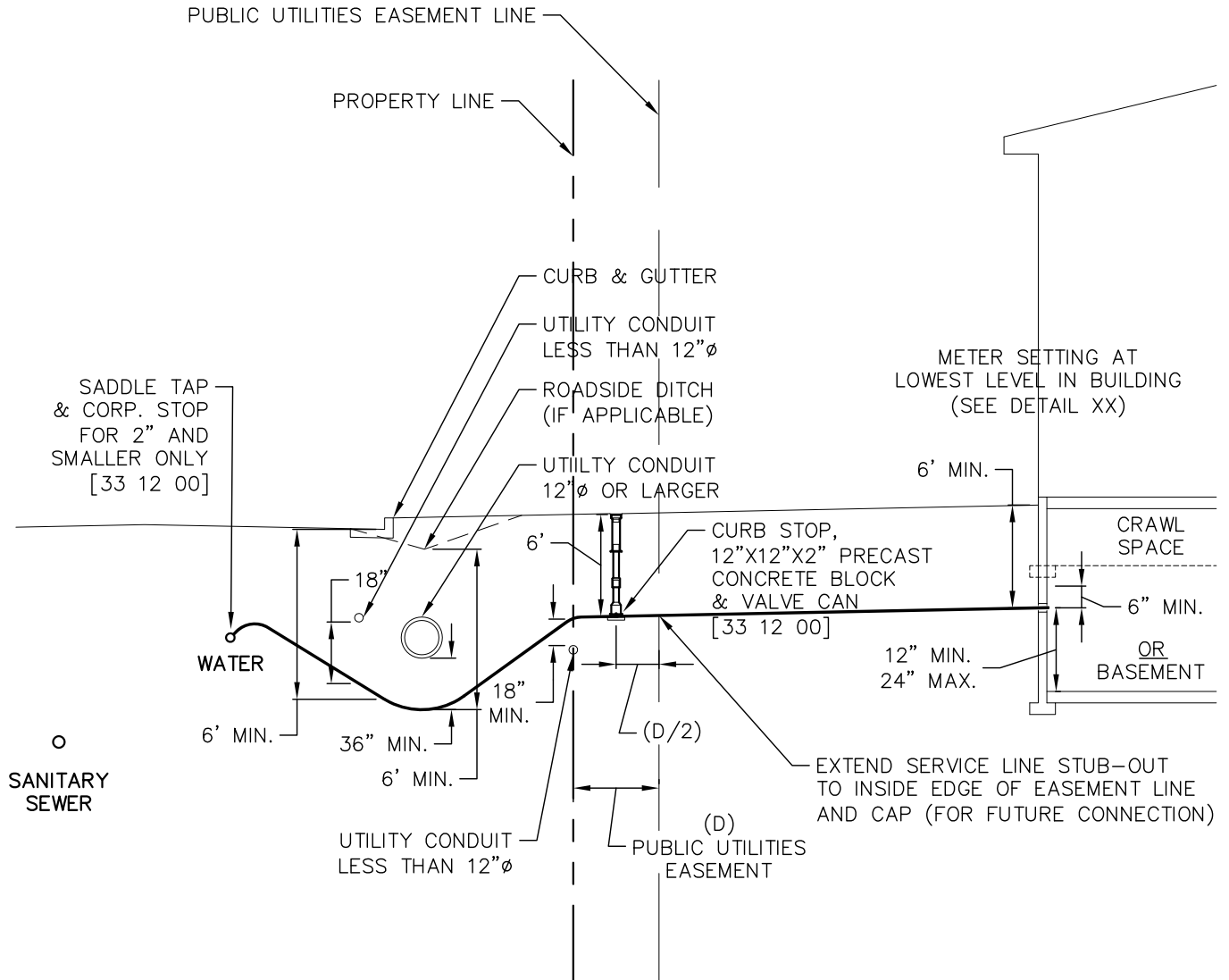

① WATER SERVICE (3/4" TO 2")
1"=10'

	WATER SERVICE (3/4" TO 2")	G-6
	GENERAL	-
	<small>THIS CONSTRUCTION DETAIL SHOWS GENERAL CONFORMANCE TO SYSTEM SPECIFICATIONS AND MAY NEED TO BE ADJUSTED FOR SPECIFIC APPLICATIONS.</small>	
		MAY 13, 2014

REFER TO WATER & SEWER SERVICE LINE EQUIPMENT SPECIFICATIONS FOR SUPPLEMENTAL INFORMATION
(APP C OF THE SYSTEM SPECIFICATIONS)

GENERAL NOTES:

- MECHANICAL JOINT RESTRAINTS REQUIRED ON ALL FITTINGS.

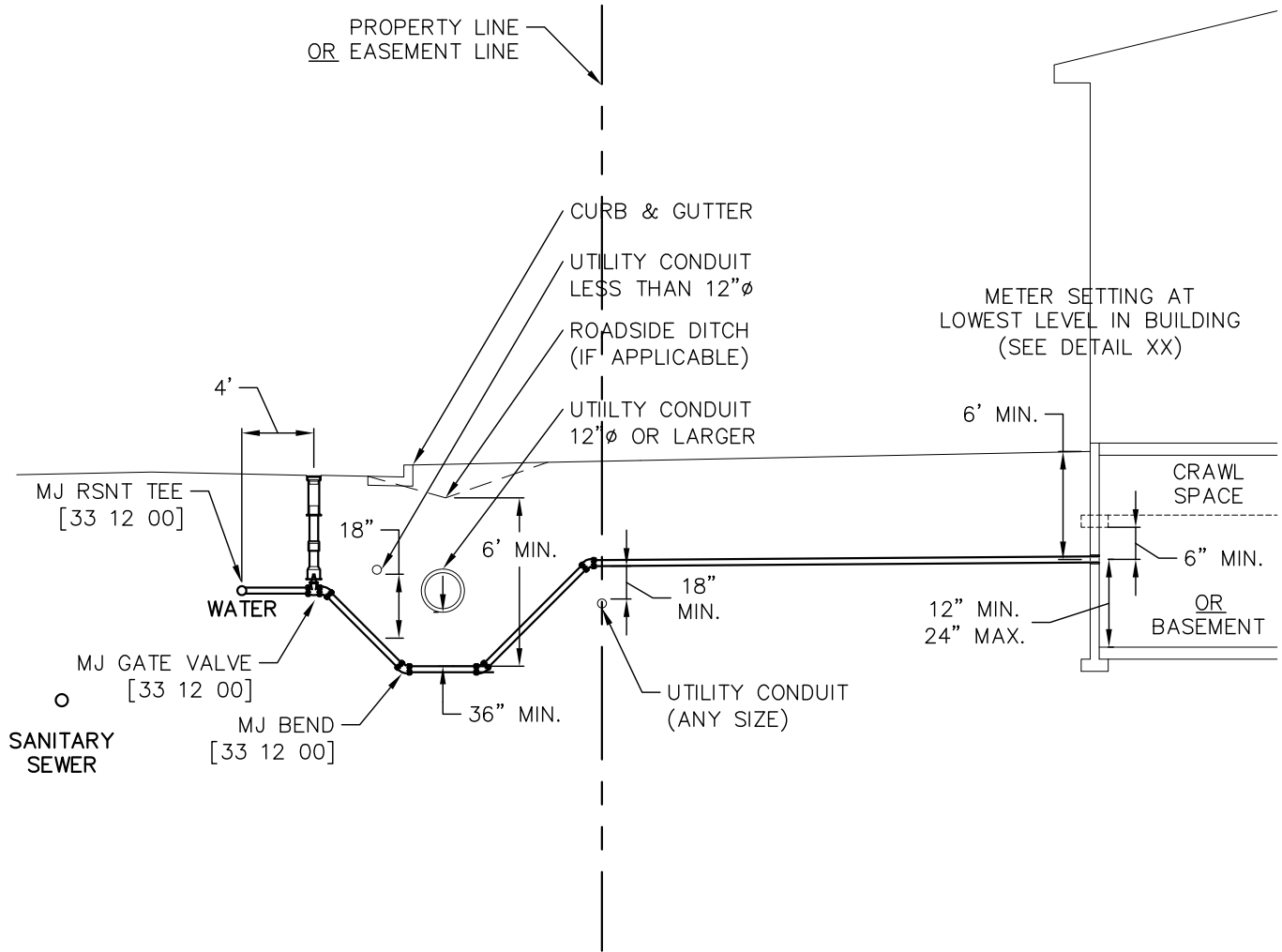

1 WATER SERVICE (2-1/2" TO 6")
1"=10'

	WATER SERVICE (2-1/2" TO 6")	G-7
	GENERAL	-
	THIS CONSTRUCTION DETAIL SHOWS GENERAL CONFORMANCE TO SYSTEM SPECIFICATIONS AND MAY NEED TO BE ADJUSTED FOR SPECIFIC APPLICATIONS.	MAY 13, 2014

REFER TO WATER & SEWER SERVICE LINE EQUIPMENT SPECIFICATIONS FOR SUPPLEMENTAL INFORMATION
(APP C OF THE SYSTEM SPECIFICATIONS)

GENERAL NOTES:

- PROVIDE METAL T-POST AT CURB STOP WHEN CONSTRUCTION OF STUB-OUT TO LOT IS COMPLETE. T-POST MAY BE REMOVED AFTER CONNECTION TO SERVICE STUB.
- INTERMEDIATE CLEAN-OUT ASSEMBLIES REQUIRED AT 100' INTERVALS (FOR UNI-DIRECTIONAL) OR 200' INTERVALS (FOR BI-DIRECTIONAL) BETWEEN PROPERTY LINE CLEAN-OUT AND BUILDING CLEAN-OUT..

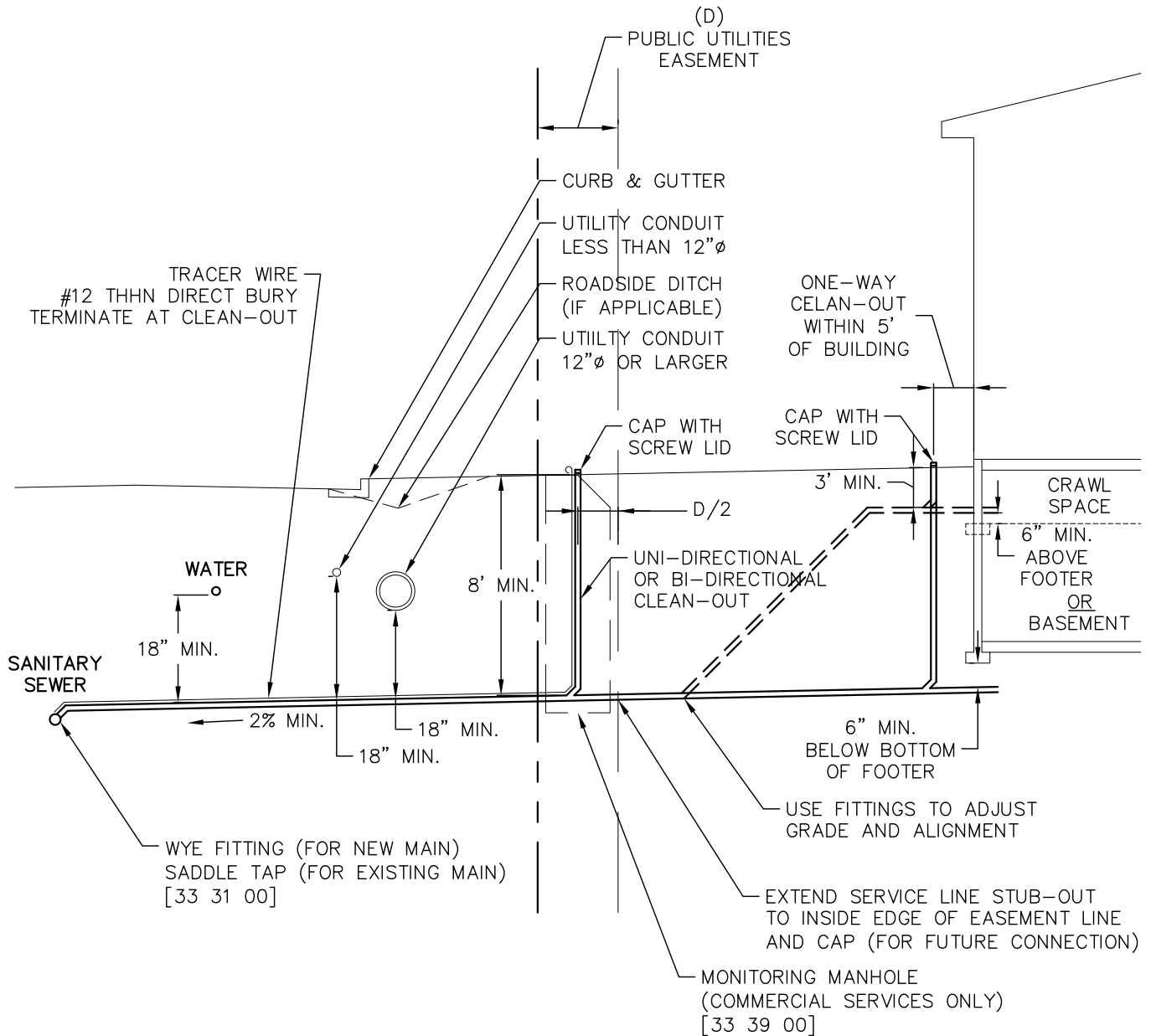

1 TYPICAL SEWER SERVICE (SECTION)
1"=10'

 WOODMOOR WATER & SANITATION DISTRICT NO. 1	TYPICAL SEWER SERVICE (SECTION)	G-8
	GENERAL	-
	THIS CONSTRUCTION DETAIL SHOWS GENERAL CONFORMANCE TO SYSTEM SPECIFICATIONS AND MAY NEED TO BE ADJUSTED FOR SPECIFIC APPLICATIONS.	MAY 13, 2014

REFER TO WATER & SEWER SERVICE LINE EQUIPMENT SPECIFICATIONS FOR SUPPLEMENTAL INFORMATION
(APP C OF THE SYSTEM SPECIFICATIONS)

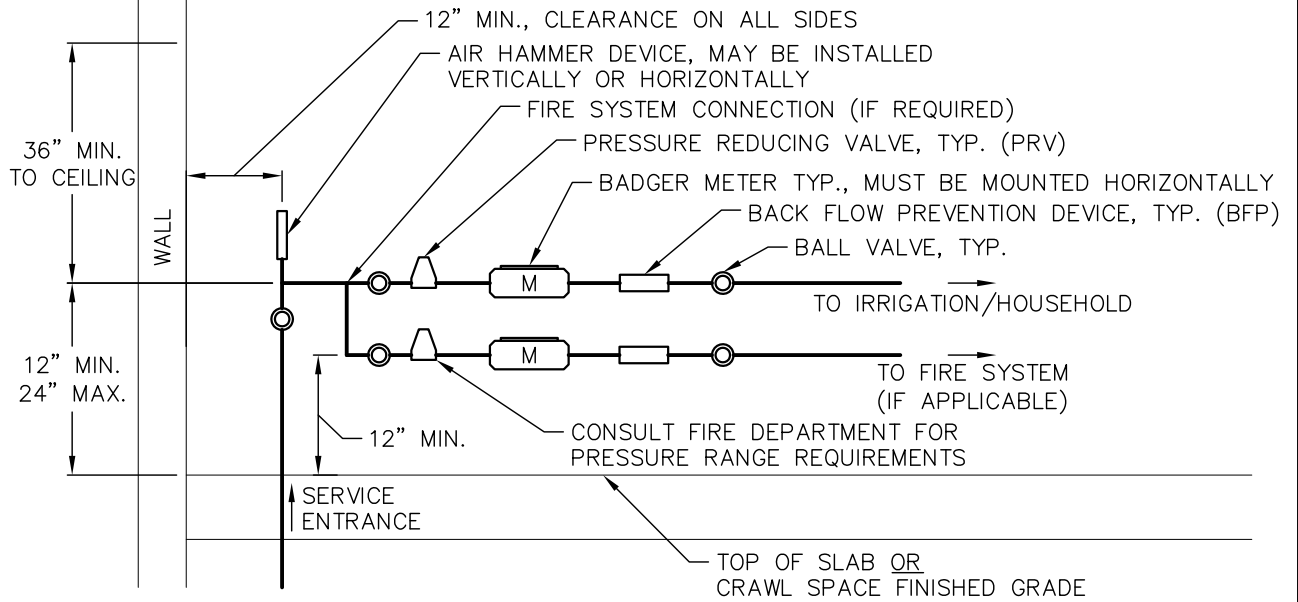

1 WATER METER SETTING (RESIDENTIAL)
NOT TO SCALE

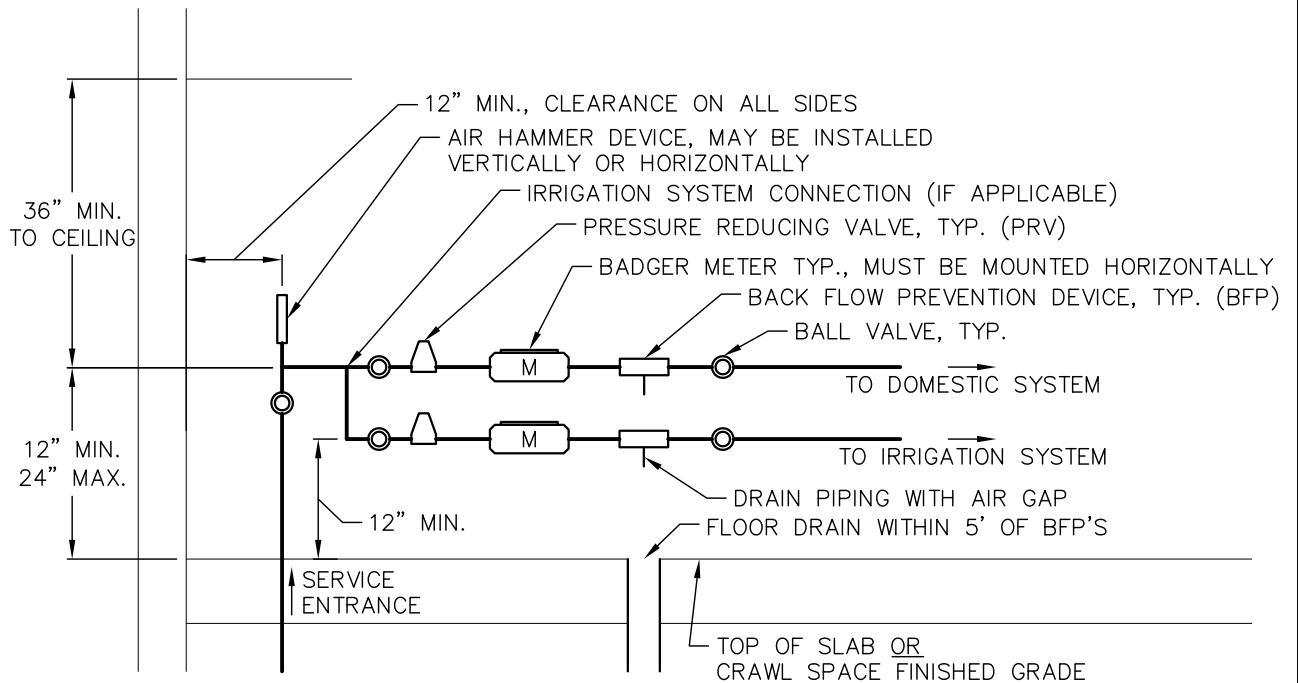

1 WATER METER SETTING (COMMERCIAL)
NOT TO SCALE



WOODMOOR
WATER & SANITATION DISTRICT NO. 1

WATER METER SETTING DETAIL

G-9

GENERAL

-

THIS CONSTRUCTION DETAIL SHOWS GENERAL CONFORMANCE TO SYSTEM SPECIFICATIONS AND MAY NEED TO BE ADJUSTED FOR SPECIFIC APPLICATIONS.

MAY 13, 2014