



WOODMOOR

Water & Sanitation District No. 1

P. O. Box 1407 • Monument, Colorado 80132

Phone (719) 488-2525 • Fax (719) 488-2530

SYSTEM SPECIFICATIONS

FOR

**DESIGN AND CONSTRUCTION OF PUBLIC OR PRIVATE
WATER OR SEWER SYSTEM IMPROVEMENTS**

VERSION: 2023.1

JUNE 2023

Table of Contents

SECTION 1	TITLE, PURPOSE, SCOPE, DEFINITIONS, AND GENERAL CONDITIONS	6
1.1	TITLE	6
1.2	PURPOSE.....	6
1.3	SCOPE.....	6
	1.3.1 Provisions	6
1.4	GENERAL CONDITIONS.....	6
	1.4.1 Monetary responsibilities.....	6
	1.4.2 Modifications.....	7
	1.4.3 Interpretation/Enforcement.....	7
	1.4.4 Violations.....	7
1.5	DEFINITIONS	7
SECTION 2	PROCEDURES	12
2.1	APPROVALS REQUIRED	12
	2.1.1 New Subdivisions, Private Commercial Development.....	12
2.2	PUBLIC IMPROVEMENTS	12
	2.2.1 Preliminary Design And Review Procedures	12
	2.2.2 Final Design And Review Procedures	12
2.3	COMMERCIAL UTILITY SERVICE PLANS AND BUILDING PLANS	14
	2.3.1 Procedures – Public Systems.....	14
	2.3.2 Procedures – Private Systems	15
2.4	BUILDING PLANS.....	15
	2.4.1 General	15
	2.4.2 Residential Service Plans	15
	2.4.3 Plan Review Fees.....	15
	2.4.4 System Improvements Agreement.....	16
	2.4.5 Letter of Credit/Guarantees.....	16

SECTION 3 DESIGN GUIDELINES..... 17

3.1 GENERAL17

3.2 WATER DISTRIBUTION SYSTEMS.....17

 3.2.1 Design 17

 3.2.2 Fire Flows 17

 3.2.3 Fire Hydrant Spacing 18

 3.2.4 Water Main Layout 18

 3.2.5 Valves..... 20

 3.2.6 Blow Off Valve Assemblies..... 20

 3.2.7 Vacuum Release Valves 20

 3.2.8 Other Valves 20

 3.2.9 Restraints 20

 3.2.10 Casing Pipe 21

 3.2.11 Service Connections..... 21

 3.2.12 Pump Stations, Booster Stations and Treatment Facilities 21

3.3 SEWER COLLECTION SYSTEMS.....22

 3.3.1 Design 22

 3.3.2 Diameter..... 22

 3.3.3 Design Slope 22

 3.3.4 Manholes/Clean-Outs..... 23

 3.3.5 Monitoring Manholes (Commercial) 23

 3.3.6 Grease Traps/Interceptors and Sand/Oil Separators (Commercial) 24

 3.3.7 Sewer Main Layout..... 24

 3.3.8 Service Connections..... 25

 3.3.9 Sewage Lift Stations, Treatment Facilities, and Pre-Treatment Facilities..... 25

3.4 EASEMENTS26

 3.4.1 General 26

SECTION 4 PLAN & PROFILE REQUIREMENTS 27

4.1	PURPOSE/APPLICABILITY	27
4.2	PLAN NOTES	27
	4.2.1 Requirements	27
	GENERAL NOTES:	27
4.3	GENERAL	29
	4.3.1 Minimum Requirements	29
4.4	COVER SHEETS (WATER AND/OR SANITARY SEWER, PUBLIC OR PRIVATE)	29
	4.4.1 Cover Sheet	29
4.5	PLAN VIEWS (SERVICE CONNECTION STUB OUTS).....	30
	4.5.1 Minimum Requirements	30
4.6	PLAN VIEWS (PUBLIC WATER).....	31
	4.6.1 Minimum Requirements	31
	4.6.2 Separations	33
4.7	PROFILE VIEW (PUBLIC WATER)	33
	4.7.1 Minimum Requirements	33
	4.7.2 Separations	34
4.8	PLAN VIEW (PUBLIC SEWER).....	35
	4.8.1 Minimum Requirements	35
	4.8.2 Separations	36
4.9	PROFILE VIEW (PUBLIC SEWER).....	36
	4.9.1 Minimum Requirements	36
	4.9.2 Separations:	37
4.10	PLANS - PRIVATE SYSTEM IMPROVEMENTS	38
	4.10.1 General Plan Requirements	38
	4.10.2 Minimum Plan Requirements	38
	4.10.3 Separations	40
	SECTION 5 CONSTRUCTION PROCEDURES	41
5.1	SYSTEM IMPROVEMENTS (PUBLIC ONLY).....	41

5.1.1 Pre-Construction Meeting	41
5.1.2 Progress Meetings	41
5.1.3 Construction Fee.....	41
5.1.4 Inspection and Observation	42
5.1.5 Utilities Testing	43
5.1.6 Interpretation/Discrepancies	44
5.1.7 Alternate Materials and Methods	44
5.1.8 Field Modifications.....	44
5.1.9 Removal or Correction of Unacceptable Work.....	45
5.1.10 Construction Closeout	45
5.1.11 Conditional Acceptance (Public System Improvements)	46
5.1.12 Final Acceptance (Public System Improvements)	48

Appendix A Standard Construction Specifications

Appendix B Standard Construction Details

Appendix C Supplemental Information

- Commercial Water & Sewer Tap Application, Service Line Sizing, & Forms
- Water and Sewer Service Line Equipment Specification

SECTION 1 TITLE, PURPOSE, SCOPE, DEFINITIONS, AND GENERAL CONDITIONS

1.1 TITLE

These requirements are to be known as the Woodmoor Water & Sanitation District No. 1 System Specifications for design and construction of system improvements.

1.2 PURPOSE

The purpose of these System Specifications is to provide general procedures, acceptable minimum standards of design, construction, type and quality of materials, location and use for standard or typical system improvements.

1.3 SCOPE

1.3.1 Provisions

- 1) The provisions of these System Specifications apply to any Person when engaged in activities that require design and/or construction of system improvements within the jurisdictional boundaries of the District.
- 2) These System Specifications do not include policies and procedures for inclusions, extra-territorial service, or supplemental water service. These topics are specifically addressed within the Rules and Regulations of the Woodmoor Water and Sanitation District No. 1.
- 3) The provisions outlined in these System Specifications include:
 - a. Minimum Design and Construction Plan Requirements for system improvements related to any public or private development.
 - b. Administrative procedures which summarize the steps to be followed in the design and approval of any system improvements prior to construction.
 - c. Construction details and construction specifications that must be adhered to during construction of system improvements.
 - d. Construction Quality Control Standards which include construction inspection, testing, and quality assurance performed by the District and/or by third parties.
 - e. Conditional and Final Acceptance Procedures for system improvements.

1.4 GENERAL CONDITIONS

1.4.1 Monetary responsibilities

Unless otherwise specified herein or in the RULES AND REGULATIONS, the Developer/Owner will be financially responsible for costs related to the design, engineering, inspections, construction, materials, testing etc. of the system

improvements, including expenses and fees paid to the District for plan review, construction inspections, and administration.

1.4.2 Modifications

In the event of a conflict or practical difficulty involved in following the provisions of these system specifications, the District may grant modifications for specific circumstances, provided the District has determined that the request for the modification is reasonable and consistent with the intent and purpose of these system specifications, and will not have an adverse or detrimental impact on the installed system improvements or the District system.

1.4.3 Interpretation/Enforcement

The District shall be the deciding authority with respect to interpretation of its Rules, Regulations, System Specifications and Policies regarding construction of any system improvements.

The District Manager or designated representative is authorized to enforce all provisions of these System Specifications.

1.4.4 Violations

It will not be permitted for any person or entity to construct, enlarge, alter, repair, relocate, improve, remove, excavate, convert, demolish, or operate any public improvements or common facilities, nor permit the same to be done in violation of these System Specifications or the Rules and Regulations.

1.5 DEFINITIONS

ACTUAL COSTS: All direct and indirect costs attributable to any project or undertaking. Actual costs to the District shall include but not be limited to, its engineering, legal, labor, material, equipment, administrative, and overhead expenses, calculated in accordance with the rates set forth in Appendix B of the Rules and Regulations and all direct payments to third parties, at cost.

APARTMENT: A dwelling unit located in a building where other dwelling units are located and where a common landlord holds title to each dwelling unit and all common areas.

APARTMENT BUILDING: A building containing a group of apartments.

BOARD OR BOARD OF DIRECTORS: The duly constituted Board of Directors of the District.

BUSINESS DAY: Monday, Tuesday, Wednesday, Thursday; excepting legal holidays.

COMMERCIAL PROPERTY: Land intended for uses that includes, but is not limited to office buildings, industrial facilities, restaurants, medical centers, hotels, apartments, condominiums, retail stores, golf courses, schools, warehouses, garages, and others.

COMMERCIAL DEVELOPMENT: Water and/or wastewater system improvements including service lines, dedicated fire lines, dedicated irrigation taps, etc. that service commercial properties.

CONDITIONAL ACCEPTANCE: Includes any conditions and stipulations related to acceptance of water or wastewater system improvements by the District, and initiates the effective date of the warranty period for improvements that are ready to be placed into service and have been completed in accordance with all District Rules and Regulations.

CONDOMINIUM: An arrangement whereby more than one dwelling unit or business unit exists on a parcel of land, and each unit is identified by a separate tax identification number on file with the County, and each tenant may hold full title to their unit and have a joint ownership in the common ground.

CONDOMINIUM BUILDING: A building containing a group of condominiums.

CONSTRUCTION DOCUMENTS: All documents related to an approved subdivision or commercial development, to include water and sewer construction plans, specifications for design and construction of water and wastewater facilities, written work directives, and all written amendments to the plans or specifications.

CONTRACTOR: Any person who performs any work, either for himself or another, on any water or wastewater or irrigation facility, public or private, within the District, including all subcontractors, agents, employees, officers and other representatives of such person.

CUSTOMER: any person authorized to use the District system under a permit issued by the District.

DAY OR CALENDAR DAY: Calendar day.

DESIGNATED REPRESENTATIVE: A person authorized to act on the behalf of another person with authoritative limitations granted to him from the authorizing person.

DEVELOPER: Any person and/or their designated representative who is the owner or developer of real property within the District's jurisdiction, and desires service from the District or the right to construct any public or private system improvements.

DISTRICT: Woodmoor Water and Sanitation District No. 1, its employees, agents, officers, directors, insurers, and professional consultants.

DISTRICT SYSTEM: The plants, facilities, systems, assets, and appurtenant property rights owned or directly controlled by the District, including the District Water Service Lines.

DISTRICT WATER SERVICE LINE (PUBLIC): That portion of a service line that runs from the water main to a District customer's property line or curb stop, whichever is closer to the water main, excluding the curb stop and the stop box.

DWELLING UNIT: One or more rooms arranged and designed and used as living quarters for a single-family unit and necessarily including individual bathrooms and complete kitchen facilities.

ENGINEER: The engineering firm(s), or duly authorized representative(s), designated by the District to act on its behalf in all engineering and related matters, including any inspectors employed by the engineer.

EXTRA-TERRITORIAL PROPERTY OWNER: Any person who, whether solely or with others, owns real property being served by the District extra-territorially. When the property is owned by more than one person, the term includes all the owners thereof. As used in the Rules and Regulations, the term shall apply to such person only in connection with their ownership of any specific parcel of real property involved in any specific matter governed by the Rules and Regulations.

FINAL ACCEPTANCE: The conveyance of ownership and maintenance obligations of system improvements within the District upon satisfactory completion of the conditions and/or stipulations associated with the terms of Conditional Acceptance certificate and final inspection.

FAMILY UNIT: An individual or two or more persons related by blood, marriage, adoption, as guardian and ward or similar legal relationship, or a group of not more than five persons (excluding employees) who need not be related by blood, marriage or adoption living together in a dwelling unit, and provided that family unit as defined herein shall include family as that term is defined by any applicable local laws.

FIXTURE UNIT: A numerical value assigned to different types of plumbing fixtures corresponding to demand on District system and flow generation.

FOREIGN MATERIALS: Anything other than treated potable water with respect to that part of the District system designed and used for the disbursement of treated water; and anything other than normal residential wastewater with respect to that part of the District system designed and used for collecting wastewater.

INSPECTOR: Designated representatives of the District responsible for observing that improvements to public or private systems are constructed and/or installed consistent with the approved design plans, using approved materials, and follow the construction requirements per the District System Specifications.

MAIN(S): Pipelines used to transport water or sanitary sewer flows.

MULTI-FAMILY UNIT (MFU): A dwelling unit that is separated from another dwelling unit by a common wall or partition, such as a townhome or condominium.

NON-POTABLE WATER: Water that does not meet the standards for drinking quality, such as lake or river water, but may still be used for other purposes, such as irrigation.

OFF-SITE FACILITIES: Any infrastructure and any increase in the size of any part of the existing District system, which is located outside of a particular piece of property being developed but constructed as a result of the development of that piece of property.

ON-SITE FACILITIES: Any infrastructure and any increase in the size of any part of the existing District system, which is located within a particular piece of property being developed and constructed as a result of the development of that piece of property.

OWNER: see PROPERTY OWNER

PERMITTED PREMISES: The land area and improvements thereto which water service or wastewater service is limited under any particular permit.

PERSON: Any individuals, associations, corporations, firms, property owners, partnerships, and bodies politic and corporate.

POTABLE WATER: Water that is safe to drink.

PUBLIC SYSTEM: See DISTRICT SYSTEM

PRIVATE SYSTEM: Any system improvements and appurtenant property rights that are not deemed or required to be publicly owned by the District. Reference District Rules and Regulations for improvements required to be dedicated to the District.

PROPERTY OWNER: Any person who, whether solely or with others, owns real property within the District. When property is owned by more than one person, the term includes all owners thereof. As used in these Rules and Regulations, the term shall apply to such person only in connection with their ownership of any specific parcel of real property involved in any specific matter governed by these Rules and Regulations.

RECORD OR AS-BUILT DRAWINGS: A separate set of full-scale construction plans, in hard copy and digital format, as requested by the District, marked to indicate complete and accurate field-installed conditions of the actual construction.

RESIDENTIAL LOT EQUIVALENT: Any piece of property, residential or commercial, as originally platted, or subsequently re-platted, to which the County Assessor's office has assigned a separate identification number. The term Residential Lot Equivalent shall not include golf courses or common areas, or any other area platted for common usage.

RESIDENTIAL PROPERTY: Land used for dwelling and/or habitable purposes in which single-family or multi-family housing units predominate.

SANITARY SEWER OR SEWER: A system of pipes and associated facilities that operate separately and independently from storm water sewer, and are used for the collection of human waste and wastewater from buildings or structures.

SERVICE LINES (PRIVATE): All pipe, fittings, and appurtenances, which (1) convey water from the District water service line to the plumbing of the permitted premises or (2) carry wastewater away from the permitted premises for discharge into a District sanitary sewer main.

SINGLE FAMILY EQUIVALENT OR SFE: A relative measure of demand placed on the District system by an average single-family residential unit. SFE values shall be assigned to specific uses and development in accordance with the Standard Demand Table.

SINGLE FAMILY RESIDENTIAL UNIT: See DWELLING UNIT

STANDARD DEMAND TABLE: A list of estimated water usage per unit of measurement for different types of water users.

STUB OUT: An extension of a service line from the main to the property line.

SYSTEM IMPROVEMENTS: Any construction, enlargement, alteration, relocation, removal, abandonment, conversion, demolition, repair, and/or excavation of any water or wastewater related infrastructure, including main extensions, whether public or private (including offsite improvements), necessary to provide for or facilitate utility service to areas within or outside of the Districts service area.

SYSTEM SPECIFICATIONS: The provisions of the System Specifications, as now or hereafter constituted, adopted by the Board of Directors, which prescribe the minimum technical standards and related requirements for the design, installation, construction, operation, use, maintenance, repair, replacement and disconnection and abandonment of all water and wastewater facilities, public and private, within the District.

TAP ABANDONMENT: The complete physical disconnection and removal of the water and/or sewer tap on the main, together with the permit for the same.

TAP OR SERVICE CONNECTION: The physical connection to a main which, together with the permit for same, effects water and/or wastewater service to a permitted premises.

TOWNHOME: A dwelling unit in a row of at least two dwelling units in which each unit is identified by a separate tax identification number on file with the County and each tenant may hold full title to their unit and the ground underneath it, and each unit has its own front and rear access to the outside, no unit is located over another unit, and each unit is separated from any other unit by one or more vertical common fire-resistant walls.

TOWNHOME BUILDING: A building containing a two or more townhomes.

WASTEWATER: See SANITARY SEWER

SECTION 2 PROCEDURES

2.1 Approvals required

2.1.1 New Subdivisions, Private Commercial Development

No person or entity will commence any construction to improve, alter, or connect system improvements to the Districts system without prior written consent or approval of final construction plans and/or applicable District agreements or permitting.

2.2 Public Improvements

2.2.1 Preliminary Design And Review Procedures

Submission and review of preliminary construction plans for system improvements as a result of land use processes through other agencies may occur. The District will review such plans and provide general and preliminary comments. Comments on any preliminary plans are reviewed to indicate major items that may prevent the project from moving forward. As the project progresses through any land use authority, Developer/Owner must adhere to the provisions outlined below for detailed approval by the District and construction commencement.

2.2.2 Final Design And Review Procedures

- 1) As a part of any preliminary design and review procedures (noted above), or as a part of final design and review procedures, the District or Developer/Owner may request a project meeting to discuss the intent and scope of the system improvements project.
 - a. The purpose of this meeting is to share all available information and discuss general project design approach, design alternatives, District processes, procedures, and requirements (such as supplemental water service), as well as construction sequences and processes, etc. for advancing the project.
 - b. An estimated project timeline and scope of work required for design review and construction supervision will be discussed with the Developer/Owner.
 - c. It is recommended that a meeting take place before the District reviews any plans.
- 2) At Developer/Owner discretion and any time during the development of final constructions plans, Developer/Owner may request a meeting with District

staff to discuss specific design considerations, preferences, and to request guidance from the District.

- a. These meetings are informal and non-binding.
 - b. These meetings are intended to answer questions Developer/Owner may have and to clarify District requirements in order to streamline the completion of construction plans and minimize substantial change requests on subsequent formal reviews performed on construction plans.
- 3) Developer/Owner shall complete the design of the system improvements to 100% in accordance with these SYSTEM SPECIFICATIONS for the project and shall submit a minimum of (1) copy to the District for review and comment (the “review plan set”). The review plan set may be submitted to the District via referral from the land use authority having jurisdiction over the project, or may be submitted directly to the District by the Developer/Owner or at District’s request. Along with the submission of the review plan set, Developer/Owner will submit one (1) copy of the latest version of the preliminary/final plat (if applicable).
 - 4) No review will take place until the District receives both the review plan set and a copy of the preliminary/final plat.
 - 5) All plans shall be prepared by a Professional Engineer or Professional Land Surveyor (as applicable) licensed in the State of Colorado.
 - 6) If, in the sole discretion of the District, review plans are submitted and found to be significantly deficient relative to the requirements in these system specifications, the District may return the review set to the Developer/Owner unreviewed. The District will state in writing that significant deficiencies exist and will direct the Developer/Owner to design in accordance with these System Specifications.
 - 7) The District will review the plan set and submit comments, recommendations, special requirements, omissions, easement requirements, size of mains, connection points, required offsite improvements, etc., to Developer/Owner and/or the Developer/Owner’s consultants.
 - 8) The expected timeline for review shall not be less than 12 business days. At the District’s discretion, such comments may be submitted to Developer/Owner through the land use referral agency such as El Paso County and Town of Monument, etc.
 - 9) The design provisions of these System Specifications are only supplied as minimum design guidelines and the District reserves the right to request any deviations, modifications, or other special requirements not specifically addressed herein arising from the plan review process.
 - 10) Upon receipt of comments from the District, Developer/Owner shall complete and/or modify the review plans and resubmit (1) copy of the revised review plans and one (1) copy of the latest version of the preliminary/final plat to the District for a second review and comment.
 - 11) The District will review the second set of review plans and will submit comments, recommendations, special requirements, omissions, etc. to Developer/Owner and/or the Developer/Owner’s consultants as outlined in [Section 2.2.2.6](#) above. The District will provide comments and indicate any

additional major revisions (if needed) and request additional review plan sets be modified and resubmitted for further review. The District will also indicate minor revisions (if needed) be made and incorporated into the final set of plans.

- 12) Any special requirements, such as easements, supplemental water requirements, and fees, that were noted in the review comments of plans shall be completed to the District's satisfaction prior to the District's approval and signature of the final plan set.
- 13) Final sets of plans must be physically delivered directly to the District for the District's signature of approval.
- 14) During the review process if the District determines that easements or other requirements are necessary for final plan approval or prior to Conditional Acceptance of the system improvements, such easements and/or special requirements will be conveyed to the Developer/Owner or Developer/Owners consultants. Easements must be conveyed to the District prior to Conditional Acceptance.
- 15) The Developer/Owner will have completed the inclusion process (See Article 6 of the Rules and Regulations) as applicable, a Supplemental Water Service Agreement if applicable (See Article 1 and Appendix 7 of the Rules and Regulations), and any other identified requirements of the District prior to submitting final construction plans for approval signature.
- 16) All plan review fees, the system improvements agreement, and the construction deposit will be submitted to the District prior to the District signing the final plans.
- 17) The signed final plan set submitted to the District will bear an original seal of a registered professional engineer, and/or professional land surveyor as applicable, licensed in the State of Colorado.
- 18) Final plans will be submitted to the District with a request for signature.
 - a. Single or multiple copies may be submitted to the District for signature.
 - b. The District will sign and date all copies of the final plans, will retain one copy, and return remaining copies to the Developer/Owner.
 - c. The Developer/Owner will submit one (1) print copy and one (1) digital copy (in PDF format) of the final plan set with all signatures from applicable agencies (including the District).
- 19) If construction does not begin within six months of the approval date, or if construction is halted for more than six months, the construction plans shall be resubmitted for review and approval.
- 20) The District may waive any procedural requirement herein if the District determines such requirements are not necessary given the scope of the proposed project.

2.3 Commercial Utility Service Plans and Building Plans

2.3.1 Procedures – Public Systems

The procedures summarized in [Section 2.2.2](#) above will be followed for submission and approval of utility service and building plans for all system improvements not classified as residential by the District, such as commercial water and sewer service lines.

2.3.2 Procedures – Private Systems

Owner/Developer shall design the private system improvements in accordance with the design guidelines noted in [Section 3](#) and in the Districts Water Meter and Water and Sewer Service line sizing application (Appendix C, Rules and Regulations) for submission and approval by the District.

2.4 Building Plans

2.4.1 General

- 1) The District will review and provide comments on any Building plans referred to the District by the Regional Building Department.
- 2) In accordance with [Section 3](#) and the District’s Water Meter and Water and Sewer Service Line Sizing criteria, Owner/Developer shall estimate maximum irrigation demand and the maximum number of water supply and drainage fixture units and include these as part of the design plan submission.
- 3) Prior to District’s approval and signature of the Building Plans, Owner/Developer shall have completed a supplemental water agreement (if applicable), obtained a tap permit for new or modified water and/or sewer service(s) and shall have obtained approval of the utility service plan.
- 4) Modifications may be required to any previously approved utility service plan if the water and sewer service lines therein are inconsistent with the building plans.

2.4.2 Residential Service Plans

- 1) No plan submission is required for private residential system improvements, except for detached structures with water and sewer service.
- 2) A tap permit shall be obtained prior to residential construction commencing.
- 3) Construction shall be performed in accordance with the standard construction details and construction specifications (where applicable) contained in Appendices A & B.
- 4) The District reserves the right to require private residential infrastructure projects to comply with the processes outlined in in these System Specifications if determined necessary by the District.

2.4.3 Plan Review Fees

- 1) For development within the District, no plan review fees will be charged during the plan review process. However, whenever any previously approved

plans undergo a revision that requires review and approval by the District, the Developer/Owner will be subject to plan review fees.

- 2) For development outside the District (e.g., extra-territorial service, inclusions, etc.) all plan reviews are subject to plan review fees.
- 3) See the Rules and Regulations for rates set forth in Appendix B.

2.4.4 System Improvements Agreement

If an improvements agreement has been submitted to El Paso County, Town of Monument, or the entity having land use jurisdiction over the project as part of their land use/development requirements, then Developer/Owner may submit the agreement to the District for consideration in meeting the District's agreement requirement. If the District determines the agreement does not adequately address the requirements, a system improvements agreement between the District and the Developer/Owner will be required setting forth the terms and conditions applicable to the project.

2.4.5 Letter of Credit/Guarantees

- 1) In conjunction with the system improvements agreement referenced above, collateral such as an irrevocable letter of credit or other appropriate security acceptable to the District, guaranteeing performance, installation (e.g., material/labor payment) and warranty of the system improvements will be supplied to the District by the Developer/Owner.
- 2) For performance and installation guarantees, such guarantees, at a minimum, shall be in an amount equal to the estimated cost of construction as estimated by Developer/Owner and submitted to the District Manager for review and approval before any construction commences.
- 3) For Warranty guarantees, such guarantees, at a minimum, will be in an amount equal to 10% of the cost of construction and installation of the system improvements and shall be submitted to the District prior to Conditional Acceptance of the system improvements.
- 4) If collateral to guarantee performance of construction, installation, and warranty of these system improvements has been submitted to El Paso County, Town of Monument, or the entities having jurisdiction over the project as part of their land use/development requirements, then evidence of such collateral may be submitted to the District for consideration in meeting the District's guarantee requirement. The District will determine the adequacy of any guarantees submitted to land use entities in its sole, absolute, and subjective discretion.
- 5) District will not accept collateral to guarantee warranty of system improvements.

SECTION 3 DESIGN GUIDELINES

3.1 General

- 1) Developer/Owner will prepare final construction plans for review and approval by the District for system improvements.
- 2) All system improvements will comply with the requirements of these System Specifications and may include special criteria established by the District. Special criteria will be discussed during the review process or as otherwise determined necessary by the District.
- 3) The District will make available record drawings showing the location of its facilities in the vicinity of the work and otherwise comply with all applicable laws and regulations pertaining to the location of the District's underground facilities.
- 4) The design guidelines contained herein are not all encompassing and are general design considerations that are routinely encountered by the District. These guidelines are not intended to limit or constrain the designers of system components.
- 5) Deviations from these guidelines may be requested and approved on a case-by-case basis provided those deviations do not compromise maintainability, integrity, quality, or reliability of the Districts system or the systems being constructed and provided such deviations do not compromise public safety.
- 6) Any applicable local, state, and federal regulations must be adhered to.

3.2 Water Distribution Systems

3.2.1 Design

- 1) Water Mains

The District will determine the adequate hydraulic requirements of the proposed system improvements and inform Developer/Owner of any design requirements exceeding the minimums noted herein during the review process.

- 2) Service Lines (Commercial)

Design flow for service lines shall be calculated by a professional architect or professional engineer in accordance with the commercial water meter & service line sizing application and forms for new or modified service contained in Appendix C of the District's Rules and Regulations.

3.2.2 Fire Flows

- 1) It is the responsibility of the designer to consult with the applicable Fire Department having jurisdiction regarding fire flow requirements within the development.

- 2) Other than a minimum goal of 1250 gpm for new developments, the District does not mandate fire flows.
- 3) The District will supply, upon request, a current estimate of maximum fire flow capabilities at requested existing and proposed fire hydrant locations using water modeling software.
- 4) Field flow-testing of fire hydrants will not be performed without prior approval from the District.
- 5) The District does not provide fire protection and assumes no obligation or responsibility for the location, water pressure or flows from fire hydrants.

3.2.3 Fire Hydrant Spacing

- 1) It is the responsibility of the designer to consult the applicable Fire Department having jurisdiction over the development regarding the spacing and location of fire hydrants.
- 2) The District may request additional fire hydrants be installed for purposes of flushing, system maintenance, safety, or other criteria as determined necessary.

3.2.4 Water Main Layout

- 1) Water mainlines will be horizontally located such that service connection to the main is no more than 50 feet from the property line of the intended property to be served.
- 2) Water mainlines will be extended to within five (5) feet of the boundaries of future adjacent developable lands.
- 3) Water mainlines will be a minimum of six (6) inch diameter pipe unless otherwise determined by the District.
- 4) Water mainlines will be located at a six (6) foot depth below the finished grade measured from finished grade surface to the top of the pipeline. Exceptions for circumstances requiring less or more depth of cover may be considered by the District on an individual basis and will be noted on the final plans.
- 5) Every effort must be made to minimize dead end water main configurations whenever possible by providing “looping” of water mains. When looping is determined by the District to be an impractical option (e.g., end of cul-de-sacs), dead ends will be provided with a blow off assembly or fire hydrant.
- 6) Water mainlines will be horizontally located away from other parallel conduits (e.g., storm drains, culverts, etc.) at minimums noted in the Standard Construction Details. If there is conflict between the District’s standard detail and the separation noted by another utility entity, default to the more conservative distance.
- 7) Curvilinear Alignments
 - a. For PVC or ductile iron pipes 10” in diameter or less, the minimum curve radius for horizontal and vertical curvilinear alignments will be two hundred thirty (230) feet and shall begin at a point of tangency and end at a point of tangency.

- b. For pipe diameters larger than 10", consult pipe manufacturer for recommendations.
- c. Non-tangential curves or curvilinear alignments in combination with standard (or other) fittings that result in atypical curves are not allowed.
- d. Curved segments are acceptable for use in vertical alignments. However, curved segment geometry for vertical curvilinear alignments must adhere to the same principal geometry as that of horizontal curvilinear alignments.
- e. Vertical water main alignments are not permitted along parabolic vertical curves.
- f. At locations where the minimum curve radii cannot be maintained, demonstrate and note straight runs of pipe using standard fittings at inflection points.

8) PVC Pipe

- a. Horizontal deflection or vertical grade breaks at pipe bell & spigot joints are **not** allowed. Horizontal deflection and vertical grade changes for PVC pipe must be accomplished by:
 - i) Bending the pipe barrel in a curvilinear manner at minimum (or greater) radii specified above.
 - ii) Use of standard fitting bends.
 - iii) Use of high deflection couplings (in lieu of bell & spigot joints) with straight runs of pipe.
 - iv) Deflecting the pipe at mechanical joint fittings.
- b. High deflection couplings shall be limited to 2.5 degrees on the inlet and 2.5 degrees on the outlet for a maximum total fitting deflection of 5 degrees.
- c. Standard mechanical joint fittings shall be limited to 5 degrees deflection on the inlet and 5 degrees deflection on the outlet.
- d. Standard 20-foot lengths of pipe shall be used.

9) Ductile Iron Pipe

- a. Horizontal deflection or vertical grade breaks at pipe bell & spigot joints are allowed.
- b. Horizontal deflection and vertical grade changes for ductile iron pipe cannot be accomplished by bending the pipe barrel. These must be accomplished using standard fittings or by deflecting each bell & spigot joint such that an equivalent curvilinear alignment is produced of minimum or greater radii specified above.
- c. Bell and spigot joints shall be limited to 5 degrees maximum deflection at the joint for pipe 10" in diameter or less.
- d. Standard mechanical joint fittings shall be limited to 5 degrees deflection on the inlet and 5 degrees deflection on the outlet of the fitting.
- e. Standard 20-foot lengths of pipe shall be used.

3.2.5 Valves

- 1) Main line isolation valves will be placed with a maximum spacing of five hundred (500) feet in all mains.
- 2) Fire hydrant isolation valves will be located on the fire hydrant lateral and within five (5) feet of the lateral connection to the main.
- 3) Three-way main line intersections will require three (3) valves and four-way main line intersections will require four (4) valves. Valves will be installed according to these configurations at all new locations and connection points to existing mains.
- 4) When connecting to an existing main, any existing valve(s) located within 100 feet of the connection point may be used to fulfill the valve spacing requirements.
- 5) Valves will be placed on each side of a major street, creek, or channel, or at locations determined necessary by the District.

3.2.6 Blow Off Valve Assemblies

- 1) Blow off taps and blow off hydrant assemblies will be installed at each low point and dead end of any mains or at locations as may be requested by the District.
- 2) Fire hydrants may be installed and serve as blow off assemblies provided that the fire hydrant lateral is located at the low point or at the end of the main.

3.2.7 Vacuum Release Valves

- 1) Vacuum release valves shall be sized in accordance with the manufacturer's recommendations but in no event shall the valve be less than 2" in size.
- 2) Vacuum release valves will be installed in a vault at each high point or at locations as may be requested by the District.
- 3) A fire hydrant may be installed and serve as a manual vacuum release valve provided the fire hydrant tee on the main is located within two (2) feet of the high point.

3.2.8 Other Valves

The District may require specific valve configurations such as flow control, pressure sustaining, pressure regulating, surge arrestors, vacuum release, etc. to be installed at locations as determined necessary. Designer shall consult with the District for specific details and design criteria.

3.2.9 Restraints

Approved mechanical joint restraint devices will be installed on all mechanical fittings. Concrete thrust restraints will not be used in lieu of mechanical joint restraint devices.

3.2.10 Casing Pipe

Casing pipe will be required at all major street, conduit and channel crossing or other locations as determined necessary by the District.

3.2.11 Service Connections

- 1) Service line stubs for residential developments will be installed from the main(s) to the property boundary for each lot to be served. Service line stubs will be installed in conjunction with main lines being installed and will tap the main(s) from the front (street) side of each lot to be served. Installation of service line stubs for non-residential developments is not permitted.
- 2) A minimum of 10 feet of horizontal separation must be maintained between water service lines and sewer service lines.
- 3) Service lines/stubs shall have six (6) feet of cover at the curb stop.
- 4) Water service line stubs will be 3/4-inch in diameter and installed such that the curb stop is located 5 feet into the property or centered within the front lot easement, whichever is less and a minimum of 10 feet from any sewer service line/sewer clean out.
- 5) Water service taps will not be located within 30" from a pipe bell, valve, mechanical connection, or tapped on a fire hydrant lateral. Water taps will maintain minimum five (5) foot spacing from other taps on the water main.
- 6) Direct tapping of water service line corporation stops (e.g., without saddle) will not be permitted on PVC pipe but is permitted on new installations of ductile iron pipe.
- 7) Fire Suppression Service Lines
 - a. Service lines for commercial buildings that are dedicated solely to fire suppression systems are allowed to tap the water main line and be separate from the building's water service line.
 - b. Dedicated fire suppression lines of 2 1/2-inch diameter and larger shall have an isolation valve installed within five (5) feet of the connection to the main in lieu of the corporation stop and curb stop.
 - c. For residential dwellings requiring dedicated fire suppression systems, the fire suppression feed line is not allowed to be separate from the domestic water service line.
 - i) The fire suppression feed line shall branch off from the water service line after (downstream of) the surge arrestor and meter, and the branch shall have a reduced flow backflow prevention (RPBFP) assembly in the configuration shown in the Standard Construction Details.

3.2.12 Pump Stations, Booster Stations and Treatment Facilities

- 1) Proposed system improvements that treat or pump water will be discussed with the District during the design and review procedures as outlined in Chapter 2.
- 2) The District will provide the Developer/Owner with specific design criteria and construction plan formats.

3.3 Sewer Collection Systems

3.3.1 Design

- 1) Sewer Mains

The District will verify proposed sewer line sizes for hydraulic capacity and inform Developer/Owner of any design requirements in excess of minimums or maximums noted herein during the review process.

- 2) Service Lines (Commercial):

Peak drainage flow for service lines shall be calculated by an Architect or Professional Engineer in accordance with the commercial sewer service line sizing application and forms for new or modified service contained in Appendix C of the District Rules and Regulations.

3.3.2 Diameter

- 1) Mains

Design diameter shall be capable of conveying peak hour design flows at proposed slopes while maintaining a d/D ratio of 0.5 or less where d = the depth of flow and D = the internal diameter of the pipe. No sewer main line shall be less than 8-inch in diameter

- 2) Service Lines (Commercial)

Design diameter shall be capable of conveying peak hour design flows at proposed slopes. No service line shall be less than 4-inch in diameter.

3.3.3 Design Slope

The following minimum and maximum slopes will be maintained when designing sanitary sewer collection systems and service lines:

Nominal Pipe Diameter (Inches)	Minimum Slope (Percent)	Maximum Slope (d/D = 0.83) (Percent)
4 (Service)	2.0 % or 1/4 inch/ft	12.00 %
6 (Service)	1.0 % or 1/8 inch/ft	10.00 %
8	0.50 %	10.00 %
10	0.35 %	6.00 %
12	0.25 %	4.00 %
15	0.20 %	3.00 %

Table 1: Maximum Sanitary Sewer Slope by Pipe Diameter

During the review process the District may request the slope of sewer reaches be revised to provide ease of maintenance, cleansing velocities, etc.

3.3.4 Manholes/Clean-Outs

1) Mains

- a. Manholes will be a minimum inside diameter of 48-inches for pipe 15-inches and smaller in diameter. For pipe greater than 15-inches but less than or equal to 24-inches in diameter the manholes will be a minimum inside diameter of 60-inches.
- b. Manholes will be spaced no further than 500 linear feet apart.
- c. Manholes will be installed at every change in horizontal or vertical alignment of pipe and for curvilinear alignments; at points of compound and reverse curvature and wherever practical, at the PC and/or PT of curvilinear sewer alignments.
- d. Maximum sewer flow deflection through manholes will be 90-degrees.
- e. The elevation drop through the trough of a manhole shall be 0.30 feet.
- f. Manholes with exterior drops (e.g., upstream of the manhole trough) are permitted. See Standard Construction Detail S-4.

2) Service Line Clean Outs

- a. A clean out is required at the building foundation and at the property line.
- b. Clean outs shall be installed on the service line at maximum intervals of 100 feet if using unidirectional style clean outs or at maximum intervals of 200 feet for bidirectional clean outs.

3.3.5 Monitoring Manholes (Commercial)

- 1) A standard 48-inch inside diameter manhole shall be installed on the service line for monitoring and sampling purposes.
- 2) If more than one building is to be served in the development, each individual building shall have its own service line and monitoring manhole provided each building is located on separate lots.
- 3) In the event more than one commercial building is to be served and those buildings are located on a single lot, then only one monitoring manhole may be required provided each buildings service line is installed into the monitoring manhole in such a manner as to allow easy and independent access and testing of each building's sewage effluent flow into the manhole.
- 4) Monitoring manholes will be located upstream of the District main line and be located in an easement or right-of-way accessible to District personnel.

3.3.6 Grease Traps/Interceptors and Sand/Oil Separators (Commercial)

- 1) Grease traps, grease interceptors and sand/oil separators will be discussed on a case-by-case basis during the review process and may be required if determined necessary by the District and/or the regulatory authority having jurisdiction.
- 2) Sanitary sewer flows shall remain separate from flows through traps, interceptors, and separators.
- 3) Requirements of design and construction shall be pursuant to the District Rules and Regulations.

3.3.7 Sewer Main Layout

- 1) Sewer mainlines will be horizontally located such that service connection to the main is no more than 50 feet from the property line of the intended property to be served.
- 2) Sewer mainlines will be a minimum of eight (8) inches in diameter pipe unless otherwise determined by the District. Sewer mainlines will be extended to within five (5) feet of the boundaries of future adjacent developable lands.
- 3) All sewer mainlines should have a minimum of eight (8) feet of cover and a maximum of sixteen (16) feet of cover measured from existing grade or final grade (whichever is lowest in absolute elevation) to the top of the pipe.
- 4) Exceptions to design may be approved by the District and shown on the final plans for circumstances requiring less or more depth of cover and will be determined on a case-by-case basis by the District.
- 5) Curvilinear Horizontal Alignments
 - a. For PVC or ductile iron pipes 10" in diameter or less, the minimum curve radius for horizontal curvilinear alignments will be two hundred thirty (230) feet and shall begin at a point of tangency and end at a point of tangency. Curvilinear vertical alignments not allowed for sewer.
 - b. For pipe diameters larger than 10", consult pipe manufacturer for recommendations.

- c. Non-tangential curves or curvilinear alignments in combination with standard (or other) fittings that result in atypical curves are not allowed.
- 6) Horizontal deflection at pipe bell & spigot joints are not allowed for PVC pipe. Standard 14- or 20-foot lengths of pipe shall be used. Horizontal deflection for PVC sewer pipe must be accomplished by:
 - a. Bending the pipe barrel in a curvilinear manner at minimum or greater radii specified above using manual non-mechanical force, or
 - b. Changing the direction of the alignment using a manhole, or
 - c. The use of 3-degree elbow bends.
 - 7) Sewer mains will be horizontally separated from potable water lines a minimum of ten (10) feet from outer wall to outer wall and be horizontally separated from other parallel conduits (e.g., storm drains, culverts, etc.) at minimums noted in the District's Standard Construction Details G-3, G-4, and G-5.
 - 8) Casing pipe will be required at all major street, conduit and channel crossings or other locations as determined necessary.

3.3.8 Service Connections

- 1) Service line stubs for residential developments will be installed from the main(s) to the property boundary for each lot to be served.
- 2) Service line stubs will tap the main(s) from the front (street) side of each lot to be served.
- 3) Installation of service line stubs for non-residential developments is not permitted.
- 4) Sewer service line stubs will be installed such that the sewer service clean out is located five (5) feet into the property or centered in the front lot easement, whichever is less, and be located a minimum of ten (10) feet away from any side lot line.
- 5) All sewer service lines shall be a minimum of 4-inch in diameter.
- 6) Sewer service lines/stubs shall have a minimum of three (3) feet of cover at the property line clean out.
- 7) Service tap connections will be located a minimum of five (5) feet away from any manhole, pipe bell, or other tap.
- 8) On installations of new sewer mainlines, service taps must be installed at the main with a gasketed wye fitting.
- 9) For service tap connections to existing sewer mainlines, a sewer service saddle tap may be installed.

3.3.9 Sewage Lift Stations, Treatment Facilities, and Pre-Treatment Facilities

- 1) Proposed system improvements that treat or pump sewer will be discussed with the District during the design and review procedures as outlined in Chapter 2.

- 2) The District will provide the Developer/Owner with specific design criteria and construction plan formats.

3.4 Easements

3.4.1 General

- 1) All existing and future system improvements owned by the District will be contained within dedicated easements or public rights-of-way.
- 2) Easement widths for sewer pipe installations shall be a minimum width of thirty (30) feet or as determined by the District.
- 3) Easement widths for water pipe installations shall be a minimum width of twenty (20) feet, with ten (10) feet on either side of pipeline centerline, or as determined by the District.
- 4) All easements will be finalized by a separate easement agreement between the District and the Developer/Owner or, if approved, by final plat.
- 5) No separate easement agreements will be required provided all system improvements reside within public rights-of-way owned by a public entity such as El Paso County or the Town of Monument.

SECTION 4 PLAN & PROFILE REQUIREMENTS

4.1 Purpose/Applicability

This Section applies to all plans required to be submitted to the District for review and approval prior to construction in accordance with these System Specifications. In general, any subdivision, water or sewer main extensions, and commercial service lines must adhere to these plan and profile requirements for submission and approval by the District prior to construction of any system improvements. Private residential service lines and improvements do not require any plan submission unless determined necessary by the District.

4.2 Plan Notes

4.2.1 Requirements

The applicable/required plan notes in this section shall be placed on the cover sheet of the plan set.

GENERAL NOTES:

1. ALL MATERIALS AND INSTALLATION PROCEDURES WILL COMPLY WITH THE SYSTEM SPECIFICATIONS AND THE RULES AND REGULATIONS OF WOODMOOR WATER AND SANITATION DISTRICT NO. 1.
2. DEVELOPER/OWNER OR CONTRACTOR SHALL BE RESPONSIBLE FOR DETERMINING AND OBTAINING ANY AND ALL PERMITS REQUIRED TO PERFORM THE WORK FROM ALL APPLICABLE REGULATORY AGENCIES OR ENTITIES HAVING JURISDICTION AND WILL PERFORM THE WORK IN ACCORDANCE WITH ANY AND ALL APPLICABLE ORDINANCES, REGULATIONS, LAWS, AND PERMITS ISSUED BY SUCH ENTITIES OR AGENCIES.
3. CONTRACTOR SHALL POT HOLE AND FIELD VERIFY ELEVATIONS, PIPE SIZE, TYPE, ALIGNMENT, ETC. OF EXISTING WATER LINES AT ALL NOTED CONNECTION POINTS TO THE DISTRICT'S SYSTEM.
4. IN CASE OF CONFLICT BETWEEN THESE PLANS AND THE SYSTEM SPECIFICATIONS, CONSULT THE DISTRICT PRIOR TO COMMENCING WORK.
5. CONTRACTOR SHALL SCHEDULE REQUIRED TESTS WITH THE DISTRICT A MINIMUM OF TWO (2) WORKING DAYS PRIOR TO PERFORMING SCHEDULED TESTS FOR OBSERVATION BY DISTRICT PERSONNEL.
6. BYPASS PUMPING OF EXISTING SANITARY SEWER FLOWS IS REQUIRED WHEN CONNECTING TO THE DISTRICT'S EXISTING SEWER SYSTEM. CONTRACTOR SHALL PROVIDE 100% REDUNDANT PUMPING CAPACITY

WITH CONTINUOUS SUPERVISION DURING PUMPING OPERATIONS. CONTRACTOR SHALL COORDINATE TIMING, LOCATION, ETC. OF BYPASS PUMPING OPERATIONS WITH THE DISTRICT PRIOR TO COMMENCING PUMPING OPERATIONS.

WATER AND SEWER SERVICE LINE NOTES:

1. SANITARY SEWER SERVICE TAP CONNECTIONS WILL BE LOCATED A MINIMUM OF 5 FEET AWAY FROM ANY MANHOLE, EXISTING SEWER TAP, OR PIPE BELL.
2. FOR NEW INSTALLATIONS OF SANITARY SEWER MAINLINE, SEWER SERVICE TAP CONNECTIONS TO BE INSTALLED ON THE MAIN WITH A GASKET WYE OR TEE FITTING. FOR SERVICE TAP CONNECTIONS TO EXISTING SEWER MAINLINES, A SEWER SERVICE SADDLE TAP MAY BE INSTALLED.
3. SEWER SERVICE LINES/STUBS WILL BE INSTALLED SUCH THAT A SEWER SERVICE CLEAN OUT IS LOCATED 5 FEET INTO THE PROPERTY OR CENTERED IN THE FRONT LOT EASEMENT, WHICHEVER IS LESS, AND BE LOCATED A MINIMUM OF 10 FEET AWAY FROM ANY SIDE LOT LINE. TRACER WIRE FROM THE SEWER TAP AT THE MAIN TO THE CLEAN OUT AT THE PROPERTY LINE SHALL BE INSTALLED, AND A METAL TEE POST WILL BE INSTALLED NEXT TO THE CLEAN OUT FOR PROTECTION AND EASE OF LOCATION.
4. A MINIMUM OF 10 FEET OF HORIZONTAL SEPARATION MUST BE MAINTAINED BETWEEN WATER SERVICE LINES AND SEWER SERVICE LINES.
5. WATER SERVICE LINES/STUBS WILL BE 3/4-INCH IN DIAMETER UNLESS OTHERWISE NOTED AND INSTALLED SUCH THAT THE CURB STOP IS LOCATED 5 FEET INTO THE PROPERTY OR CENTERED IN THE FRONT LOT EASEMENT, WHICHEVER IS LESS, AND A MINIMUM OF 10 FEET FROM ANY SEWER SERVICE LINE OR SEWER CLEAN OUT.
6. CURB STOPS AND BOXES SHALL BE BURIED SUCH THAT 6-FEET ($\pm 0'$) OF COVER EXISTS AS MEASURED FROM FINISHED GRADE TO THE TOP OF THE SERVICE LINE. A METAL TEE POST WILL BE INSTALLED AT THE CURB STOP BOX FOR PROTECTION AND EASE OF LOCATION.
7. WATER SERVICE TAPS WILL NOT BE LOCATED ON A FIRE HYDRANT LATERAL OR WITHIN 30 INCHES FROM A PIPE BELL, VALVE, OR MECHANICAL JOINT CONNECTION. WATER TAPS WILL MAINTAIN MINIMUM 5 FOOT SPACING FROM OTHER TAPS ON THE WATER MAIN.
8. DIRECT TAPPING OF WATER SERVICE LINE CORPORATION STOPS (E.G., NO SADDLE) WILL NOT BE PERMITTED ON ANY PIPE TYPE EXCEPT NEW DUCTILE IRON PIPE INSTALLATIONS.

4.3 General

4.3.1 Minimum Requirements

All plan sheets for public or private system improvements, whether related to water or sewer, must include the following items:

- 1) Submit plan set on 24" x 36" paper sheets and PDF.
- 2) Title, date, project name, plan preparer's name, company and contact information.
- 3) Construction approval signature block:

Woodmoor Water and Sanitation District No. 1

APPROVED FOR CONSTRUCTION

Date: _____ By: _____

These plans have been reviewed only for general conformance with District Rules and Regulations and System Specifications. Review and construction approval by the District does not relieve the Developer/Owner and/or Contractor from responsibility for compliance with any rules, regulations or specifications required by the District.

4.4 Cover Sheets (Water and/or Sanitary Sewer, Public or Private)

4.4.1 Cover Sheet

All plans for public system improvements will include a cover sheet with the following items:

- 1) Location map, vicinity map with north arrow.
- 2) Phase lines, subdivision boundary lines, and match lines shown on the location or vicinity map.
- 3) A clear heading, such as "Public Water System Plan", "Public Sewer System Plan", "Commercial Service Line Plan", etc.
- 4) Label horizontal and vertical coordinates for at least two horizontal control points in the vicinity of the development and graphically depict the vertical control points on the location and/or vicinity map.
- 5) A note which calls out the horizontal and vertical coordinate system for the improvements shown on the plan set, shown in [Table 2](#).

Coordinate System	US State Plane 1983
Zone	Colorado Central 0502
Datum	NAD 1983 (Conus) CORS 96
Vertical Datum	North American Vertical Datum 1988 (NAVD 88)
Coordinate Order	North/East
Coordinate Units	US Survey Feet
Altitude Reference	Height Above Ellipsoid (HAE)
Altitude Units	Feet

Table 2: Woodmoor Water & Sanitation District No. 1 GIS Coordinate System

- 6) General Notes, listed in [Section 4.2.1](#).
- 7) Water and sewer service line general notes (when applicable), listed in [Section 4.2.1](#).

4.5 Plan Views (Service Connection Stub Outs)

4.5.1 Minimum Requirements

- 1) A separate plan sheet(s) shall be constructed illustrating the location of water and/or sewer service stubs from the main to the property. Both water and sewer services may be included on the same sheet(s) as applicable.
- 2) Service line plan sheets shall show the following:
 - Lots and lot numbers
 - Streets and street names
 - Rights of Way and easements
 - Curb & gutter
 - Water and sewer main size and material type
 - Service line stub size and material type
- 3) End locations of stub outs (the curb stop box and property line clean outs) shall be symbolized with a “W” or “S” inscribed in a circle. Symbols need not be drawn to scale.
- 4) Profile views for service connection stubs are not required.

4.6 Plan Views (Public Water)

4.6.1 Minimum Requirements

- 1) Proposed water system improvements, match lines, and subdivision boundaries with required labeling information shall be graphically shown in a prominent, highlighted, or bold manner relative to non-water system improvements and non-water system improvement labels, such as roadway improvements, storm system improvements, curb and gutter, streets, rights of way, lot lines and other utilities.
 - a. If approved by the District, water and sanitary sewer utilities may be shown on the same drawing sheets.
- 2) North arrow and 1" = 50' maximum scale.
- 3) Graphically show all existing and proposed water pipe alignments and label with size and type of material.
- 4) Stationing along alignments shall be positive (e.g., 0+90 or 12+00). Negative stationing is not permitted.
- 5) Graphically show the location of all fittings, ends, and appurtenances, including but not limited to the following:
 - Valves
 - Fire hydrants
 - Blow off taps/hydrants
 - End of water mains
 - Vaults
 - Horizontal alignment changes
 - Other water structures being proposed
- 6) Label each with the general information of station, offset, description and a reference to the District's standard detail drawings (as applicable).

Examples:

STA 1+00, 5' LT, Air/Vac Release Vault, Detail W-13/W-14

STA 14+23, 10' RT, 6" Tee

- 7) In addition to the general label information, the following item specific information shall be labeled:
 - Quantity of valves to be installed at tees & crosses
 - Total deflection at fittings or horizontal alignment changes
 - Total alignment deflection through horizontal fittings
 - Rim elevation of vaults

- 8) Where one water main alignment ends by or is intersected with another water main alignment, label equation stations.

Example:

STA 1+00, 5'RT, Alignment A = Station 2+20, 5'LT, Alignment B

- 9) Graphically show the following:
 - a. All existing and proposed utilities and structures (storm, gas, electric, phone, cable, etc.) that may conflict with water system improvements and only label with size and material type (stationing and other labels shall be omitted).
 - b. Match lines. Label with stations and corresponding sheet numbers.
 - c. Streets and limits of asphalt and label street names. Note if private. Do not include signage or striping information.
 - d. Property lines and label lots with legal description and addresses.
 - e. Subdivision boundaries. Label with unique line type and legend.
 - f. Curb and gutter or centerline of roadside drainage ditches. Provide typical cross section (in relation to roadway profile) for roadside drainage ditches.
 - g. Existing and proposed rights of way and/or easements.
 - i) Label existing easements with reception number or provide placeholder "Rec# _____" for proposed easements.
 - ii) Existing or proposed platted easements shall be labeled through the use of unique line type and line type legend.
- 10) Denote alignment stationing. Clearly distinguish between road centerline and utility line stationing in plan and profile. All lengths of pipe noted in line and curve tables will be the lengths along the centerline of the utility pipeline.
- 11) For curvilinear horizontal alignments, label station and offset of the PC and PT.
- 12) Provide line and curve tables for all segments of water main along the centerline of the water main(s). Label each segment on the plan and in the table with an identifier (e.g., WL1, WL2, WC1,WC2, etc.).
 - a. Line table shall list water line segment identifier, length of segment & bearing of the segment.
 - b. Horizontal curve table shall list curve segment identifier, length of curve, radius, and delta angle of the curve.
 - c. Do not include line and curve data for ancillary items such as curb returns, roadway centerlines, or line and curve tables relative to other utilities (except sewer improvements when permitted by the District to be shown on the same plan sheet).
 - d. It is acceptable to use roadway or Right-of-Way centerline for the plan alignment stationing basis; however, for purposes of the District, line and curve tabular data along roadway centerline shall not be accepted in lieu of line and curve tables relative to centerline of water main.

- 13) Other requirements as determined necessary by the District through the review/comment process.

4.6.2 Separations

- 1) Label horizontal distance from proposed water line to other utilities in areas where separation distance deviates from the District's typical utilities cross-section.
- 2) Where water system improvements cross other utilities (existing or proposed), label the crossing point with station, offset, the term "utility crossing", size and type of utilities that cross, and crossing configuration.

Example:

STA 10+00, 10' LT, utility crossing, 6" PVC water over 30" RCP storm sewer.

4.7 Profile View (Public Water)

4.7.1 Minimum Requirements

- 1) Scale: 1" = 5' vertical or smaller size to properly show detail.
- 2) Graphically show grid and label grid elevations.
- 3) Proposed water system improvements and match lines (together with required labeling information) shall be graphically shown in a prominent, highlighted or bold manner relative to non-water system improvements and non-water system improvement labels, such as proposed or existing roadway grades, storm system improvements and other utilities.
- 4) Graphically show existing and proposed ground elevations with unique and different line types. Label whether existing or proposed (e.g., "proposed roadway centerline", "existing roadway centerline", etc.).
- 5) Graphically show water main along the alignment with 6 feet of cover from finished grade to top of pipe. Label each reach of water main between changes in vertical alignment with the following:
 - Length (calculated along centerline of water main)
 - Size and type of material
 - Slope
 - Station
 - Description (e.g., "grade break")
 - fitting type (such as 11.25 degree bend, tee, cross, high deflection coupling, joint, etc.) and total deflection

Example Labels:

STA 5+00, grade break, joint deflection (total defl = 1.2°)

STA 13+22, grade break, 11.25° bend (total defl = 13.2°)

300 LF 6" PVC Water Main @ 3% Slope

- 6) For water main proposed to be installed in a curvilinear vertical alignment, label the following:
 - Stations for the vertical PC and PT
 - Length of curve along centerline of water main
 - Radius of curve along centerline of the water main
 - Delta angle at each curve in the profile view
- 7) Graphically show the following:
 - Main line laterals
 - Fire hydrant laterals
 - Blow off taps/hydrants
 - Vaults
 - Points of connection
 - End points
 - Structures
- 8) Label with the following general information:
 - Station (without offset)
 - Corresponding equation station (without offset), if any
 - Description
 - Rim elevation
 - Vertical deflection (if any)
 - Invert elevation (as applicable)

Examples:

STA 1+00, 10' RT, Air/Vac Release, Rim Elev = 7105.23, Invert Elev = 7099.41

STA 10+17, 14.75' RT, Grade Break, 11.25⁰ Bend (tot. vert. defl. = 13.0⁰)

- 9) Note proposed depth of cover or invert elevations in areas that are proposed to be less or more than 6 feet.
- 10) Graphically show match lines and label with stations and corresponding sheet numbers.
- 11) Other requirements as determined necessary by the District through the review/comment process.

4.7.2 Separations

- 1) Graphically show every crossing where water crosses over or under any existing or proposed utilities and label each utility being crossed by the water main (e.g., “18” RCP Storm Sewer”, “Fiberoptic”, etc.).
- 2) Label elevations at the bottom of upper utility and top of lower utility. Denote dimension of clearance distance between bottom of upper utility and top of lower utility.

4.8 Plan view (Public Sewer)

4.8.1 Minimum Requirements

- 1) Proposed sanitary sewer system improvements, match lines, and subdivision boundaries with required labeling information shall be graphically shown in a prominent, highlighted, or bold manner relative to non-water system improvements and non-water system improvement labels, such as roadway improvements, storm system improvements, curb and gutter, streets, rights of way, lot lines and other utilities.
 - a. If approved by the District, water and sanitary sewer utilities may be shown on the same drawing sheets.
- 2) North arrow and 1” = 50’ maximum scale.
- 3) Graphically show all existing and proposed sewer pipe alignments and label with size and type of material.
- 4) Stationing along alignments shall be positive (e.g., 0+90 or 12+00). Negative stationing is not permitted.
- 5) Graphically show all proposed manholes and sewer structures.
- 6) Label all proposed and existing manholes with the following general information:
 - Station and any applicable offset
 - Description
 - Reference to the District’s standard detail drawings

Example:

STA 1+00, 5’ LT, 48” ID MH-1, WWSO Detail S-2

- 7) Where one sanitary sewer alignment ends or is intersected by another sanitary sewer alignment, label equation stations.

Example:

STA 1+00, 5’ RT, Alignment A = Station 2+20, 5’ LT, Alignment B

- 8) Graphically show all items listed in [Section 4.6.1.9](#).

- 9) Denote alignment stationing. Clearly distinguish between road centerline and utility line stationing in plan and profile. All lengths of pipe noted in line and curve tables will be the lengths along the centerline of the utility pipeline.
- 10) For curvilinear horizontal alignments label station and offset of the PC and PT.
- 11) Provide line and curve tables for all segments of sewer main along the centerline of the sewer main(s). Label each segment on the plan and in the table with an identifier (e.g., SL1, SL2, SC1, SC2, etc.).
 - a. Line table shall list sewer line segment identifier, length of segment & bearing of the segment.
 - b. Horizontal curve table shall list curve segment identifier, length of curve, radius, and delta angle of the curve.
 - c. Do not include line and curve data for ancillary items such as curb returns, roadway centerlines, or line and curve tables relative to other utilities (except water improvements when permitted by the District to be shown on the same plan sheet).
 - d. It is acceptable to use roadway or Right-of-Way centerline for the plan alignment stationing basis; however, for purposes of the District, line and curve tabular data along roadway centerline shall not be accepted in lieu of line and curve tables relative to centerline of sewer main.
- 12) Other requirements as determined necessary by the District through the review/comment process.

4.8.2 Separations

- 1) Label horizontal distance from proposed sewer line to other utilities in areas where separation distance deviates from the District's typical utilities cross-section.
- 2) Where sewer system improvements cross other utilities (existing or proposed), label the crossing point with station, offset, the term "utility crossing", size and type of utilities that cross, and crossing configuration.

Example:

STA 10+00, 5' RT, utility crossing, 8" PVC sewer over 30" RCP storm sewer.

4.9 Profile View (Public Sewer)

4.9.1 Minimum Requirements

All profile views for public system improvements shall contain and show the following minimum requirements:

- 1) Scale: 1" = 5' vertical or smaller size to properly show detail.
- 2) Graphically show grid and label grid elevations.

- 3) Proposed sewer system improvements and match lines (together with required labeling information) shall be graphically shown in a prominent, highlighted, or bold manner relative to non-water system improvements and non-sewer system improvement labels, such as proposed or existing roadway grades, storm system improvements and other utilities.
- 4) Graphically show existing and proposed ground elevations with unique and different line types. Label whether existing or proposed (e.g., “proposed roadway centerline”, “existing roadway centerline”, etc.).
- 5) Graphically show all proposed manholes and sewer structures. Label each with the following general information:
 - Station (without offset)
 - Equation station without offset, if applicable
 - Description
 - Rim elevation
 - Invert elevations
 - Direction of each pipe into and out of the manhole or structure
 - Total cut depth

Example:

*STA 1+00 Alignment A = 5+00 Alignment B
 48" ID Drop MH-1, Invert in (N-top) = 7094.33, Invert in (N-bot.) = 7094.02
 Invert In (E) = 7099.40, Invert out (S) = 7099.09, Detail S-4, cut = yy*

- 6) For connections to existing manholes, the same information as in [Section 4.9.1.5](#) shall be shown and provided for the existing manhole.
- 7) Graphically show proposed sewer main along each alignment. Label each reach of sewer between manholes with the following:
 - Length (calculated along centerline of sewer)
 - Size and type of material
 - Percent slope

Example:

400 LF of 8" PVC sewer at 4.00%

- 8) Graphically show main line laterals entering or exiting manholes at alignment intersections.
- 9) Graphically show match lines and label with stations and corresponding sheet numbers
- 10) Other requirements as determined necessary by the District through the review/comment process.

4.9.2 Separations:

- 1) Graphically show every crossing where sewer crosses over or under any existing or proposed utilities and label each utility being crossed by the sewer main (e.g., “18” RCP Storm Sewer”, “Fiberoptic”, etc.).
- 2) Label elevations at the bottom of upper utility and top of lower utility. Denote dimension of clearance distance between bottom of upper utility and top of lower utility.

4.10 Plans - Private System Improvements

4.10.1 General Plan Requirements

- 1) Plans for private system improvements in general are only required for commercial water and sewer service lines.
- 2) Profile views are not required for private system improvements unless specifically requested by the District given size and complexity of the project.
 - a. Requests for profiles (if any) will be made during the review process.

4.10.2 Minimum Plan Requirements

- 1) Proposed water and sanitary sewer system improvements, match lines, and subdivision boundaries with required labeling information shall be graphically shown in a prominent, highlighted, or bold manner relative to non-water system improvements and non-water system improvement labels, such as roadway improvements, storm system improvements, curb and gutter, streets, rights of way, lot lines and other utilities.
 - a. If approved by the District, water and sanitary sewer utilities may be shown on the same drawing sheets.
- 2) North arrow and 1” = 50’ maximum scale.
- 3) Graphically show all existing and proposed water and sewer service lines and label with size and type of material.
- 4) Graphically show all existing and proposed non-water/sewer utilities (storm, gas, electric, phone, cable, etc.) that may conflict with service lines, or that service lines are connecting to. Label each with type, size and material of the utility.
- 5) Label or note the following for sewer:
 - a. Type of material and diameter of the service line.
 - b. Slope of the sewer service line.
 - c. Length from the main to the monitoring manhole and from the monitoring manhole to the building sewer monitoring manhole.
 - d. The location, diameter, rim and invert elevations (in and out) of the monitoring manhole.
 - e. Invert elevations of service lines at connection points to the Districts system and at the foundation wall of the building.

- f. Sewer clean out location at the building and intermediate clean out locations.
- 6) Label or note the following for water:
 - a. Type of material and diameter of the service line.
 - b. Length from the main to the building and from the main to any meter.
 - c. For single service lines feeding two meters (irrigation + domestic), two lengths must be provided and distinctly labeled.
 - d. Water curb stop box location & valve size.
 - 7) Graphically show location of all fittings (reducers, tees, valves, etc.) and label with size and type.
 - 8) Show and label grease and/or sand/oil separators & provide cross sectional detail from the inlet to the outlet showing tank, baffles, chambers, inlet and outlet elevations, etc.
 - 9) For sewer ejector pumps, graphically show the following:
 - Location of pump or pumping station.
 - Force main w/noted minimum cover depth requirements.
 - Connection point to gravity service line.
 - Label with descriptor, size, and type of items.
 - 10) Graphically show and label the following:
 - a. Streets (note if private) and street names.
 - b. Property lines.
 - c. Driveways.
 - d. Addresses for all buildings.
 - e. Lot numbers for all lots.
 - f. Either curb and gutter or centerline of roadside drainage ditches for all streets and driveways, whichever is applicable.
 - i) Provide typical cross section (in relation to street/driveway profile) for roadside drainage ditches.
 - g. Existing and proposed rights of way and/or easements
 - i) Label existing easements with reception number or provide placeholder “Rec.#_____” for proposed easements.
 - 11) Other requirements as determined necessary by the District through the review/comment process.

4.10.3 Separations

- 1) Label horizontal distance from proposed service lines to other utilities in areas where separation distance deviates from the District's typical utilities cross-section.
- 2) Where proposed service lines cross over or under other utilities (existing or proposed), graphically show and label the following:
 - a. Crossing point with the crossing configuration.
 - b. Size and type of utilities that cross.
 - c. Bottom and top elevations of the respective crossing utilities.
 - d. Vertical clearance distance between utilities.

Example:

*8" PVC Sewer crossing, B.O.SS = 100.00', T.O. Water service line = 95.00',
clear dist. = 5.00'*

SECTION 5 CONSTRUCTION PROCEDURES

5.1 System improvements (Public Only)

5.1.1 Pre-Construction Meeting

- 1) A mandatory pre-construction meeting shall be scheduled with the District by Developer/Owner after the District has received a copy of the final construction plan set that includes signatures from all applicable agencies (including the District) and Developer/Owner has received the Districts estimate of construction fees.
 - a. The Contractor, Developer/Owner, and major subcontractors shall be among those in attendance.
- 2) The purpose of the meeting is to discuss the project in general, exchange contact information, and to review the final plan requirements, to include any special or unique provisions noted on the plan set from the review process.
- 3) In this meeting, the District will discuss general construction requirements and expectations contained within the Standard Construction Specifications and Construction Details.

5.1.2 Progress Meetings

- 1) The frequency of progress meetings shall be discussed at the pre-construction meeting and agreed upon at a time and location determined acceptable to the District.
- 2) The Owner/Developer and the Contractor will attend scheduled progress meetings to provide progress and status updates related to construction of the System Improvements.

5.1.3 Construction Fee

- 1) The District will develop an estimate of construction fees prior to the pre-construction meeting for discussion and payment by the Developer/Owner at the pre-construction meeting.
- 2) Construction fees shall include fees charged for construction observation/inspection by the District Representative, reprographics costs, any costs charged to the District as a result of third-party services such as engineering, cure charges, charges assessed as a result of violating the District Rules and Regulations (if any) including, but not limited to:
 - a. Stop work orders
 - b. Tampering
 - c. Permit violations for permits

- 3) The Developer/Owner shall deposit the estimated construction fees with the District prior to construction.
- 4) The District will track time and costs expended on engineering review, field inspections, submittal review, and other costs noted above against the deposit.
- 5) A monthly invoice summary will be provided to the Developer/Owner showing the time and amounts charged against the deposit account and the then current remaining balance.
- 6) The District will inform the Developer/Owner when 75% +/- of the deposit has been consumed and will request additional deposits that are estimated to cover the construction fees remaining to complete the project.
- 7) Any remaining unused deposits will be refunded to Developer/Owner at Conditional Acceptance.

5.1.4 Inspection and Observation

- 1) A District designated representative shall conduct on-site inspections/observations at appropriate intervals as necessary to determine that the installation of approved materials and procedures is in conformance with District System Specifications and the final construction plans. Duties of the District Representative will include the following:
 - a. Serve as a liaison between Owner/Developer, Contractor, and the District.
 - b. Assist Contractor in interpreting the construction documents.
 - c. Assist in serving as the District's liaison with Contractor when Contractor's operations affect the District's on-site or off-site operations.
 - d. Assist in obtaining from the District additional details or information when required at the job site for proper execution of the work.
 - e. Review material submittals for non-standard material proposed by Contractor and submit documentation to the District for examination and approval.
 - f. Advise Contractor of any submittal or material that has not been approved by the District.
 - g. Report to the District any work that may be unacceptable, faulty, defective, or does not conform to the final construction plans or system specifications.
 - h. Report to the District and Contractor any work that does not meet the requirements of any inspections, tests, is in need of correction or has been rejected, is covered up prior to inspection, or requires special testing.
 - i. Notify the District at least 2 days prior to any tests being conducted.
 - j. Verify that tests, equipment and system startups are conducted as per the approved construction documents
 - k. Observe, record, and report to the District appropriate details relative to the test procedures and startups.
 - l. Accompany District personnel and visiting inspectors representing public or other agencies having jurisdiction over the Project and record the outcome of these inspections.

- m. Regularly report the result of on-site observations, inspections, or testing to the District.
- n. Whenever there is insufficient evidence of compliance with any of the provisions of the final construction plans and/or the System Specifications, the District Representative will investigate and recommend to the District any tests and/or actions to be taken by Contractor or the Owner/Developer that will be used as proof of compliance.
- o. Test methods will be as specified by the Standard Construction Specifications and Construction Details, or if absent, by other recognized alternate test standards. If there are no recognized and accepted test methods, the District will determine and recommend test procedures.
- p. Witness all tests conducted by the Contractor or District-approved third parties and report results of such tests to the District.
- q. Consult with the District in regard to interpreting the “Standard Construction Specifications and Construction Details” for Contractor.
- r. Notify the Contractor of any District clarifications and/or interpretations of the final construction plans when necessary.
- s. Notify the District of any Contractor requests for modifications to the final construction plans.
 - i) The District may request additions, deletions, or revisions in the work by a Written Work Change Directive for additional work necessary to bring the system improvements into compliance.
 - ii) Work change directives will be issued to the Contractor by the District Representative.
- t. Maintain orderly files for correspondence, reports of job conferences, shop drawings, sample submissions and reproductions of plans, including all field orders/directives and additional drawings issued.
- u. Maintain written daily reports for those days in which the District Representative was on site documenting the construction progress, field tests and observations.
- v. Verify that any guarantees, certificates, maintenance and operation manuals or other data required to be assembled and furnished by Owner/Developer or Contractor are applicable to the items actually installed.

5.1.5 Utilities Testing

- 1) Where testing is required pursuant to the Standard Construction Details and Construction Specifications, the Contractor shall conduct such tests in the presence of the District Representative.
- 2) Testing may be conducted without the presence of the District Representative provided that such testing is conducted by a third party previously approved by the District to conduct and certify such tests.

5.1.6 Interpretation/Discrepancies

- 1) The District shall be the deciding authority with respect to interpretation of its Rules, Regulations, System Specifications and Policies regarding construction of any system improvements.
- 2) Any conflict, error, ambiguity, or discrepancy in the final construction plans and any provision of the Standard Construction Details and Construction Specifications or any law or Regulation applicable to the installation of the work shall be reported to the District with recommendations for resolution.

5.1.7 Alternate Materials and Methods

- 1) The provisions of the Standard Construction Details and Construction Specifications are not intended to prevent the use of any material or method of construction. However, the District shall require that sufficient evidence or proof be submitted to substantiate any claims regarding the long-term function, maintainability, and performance of an alternate method or equivalent material(s).
- 2) Product data/methods summary for any alternate materials and/or methods not covered in the Standard Construction Details and Construction Specifications shall first be submitted to the District Representative with a request for District review.
- 3) Upon receipt of such request, the District will have 21 days to review the alternate materials/methods proposed and render a decision to accept, accept with exceptions, or reject the request.
 - a. Such determination will be in writing and will be served on the Owner/Developer or Contractor by the District Representative.

5.1.8 Field Modifications

- 1) Whenever there are practical difficulties involved in carrying out the installation/testing provisions of the Standard Construction Details and Construction Specifications, the District in its sole discretion may grant a deviation from such requirements on a case-by-case basis provided that such modification does not lessen any design requirement or any degree of integrity of the constructed product.
- 2) A request for field modification will be submitted to the District Representative with a request for District review together with appropriate details and a description of the modification and reasoning of why the modification is necessary.
- 3) Upon receipt of such request, the District will review the modification request and render a decision to accept, accept with exceptions, or reject the request.
- 4) The expected timeline for review shall not be less than 5 business days and such determination will be in writing and will be served on the Owner/Developer or Contractor by the District Representative.

- 5) District actions approving a specific modification shall not be construed as a precedent approval of such modification in any subsequent request.

5.1.9 Removal or Correction of Unacceptable Work

- 1) Work which does not conform to the approved construction plans or these System Specifications, and results in an inferior or unsatisfactory product, will be considered unacceptable work.
- 2) Unacceptable work, whether the result of poor workmanship, poor design, use of defective or unapproved materials, damage through carelessness or any other cause, will be immediately removed and acceptably replaced or otherwise satisfactorily corrected by and at the expense of the Developer/Owner or Contractor.
- 3) Unacceptable work includes total and complete restoration of any disturbed surface to the original condition that existed before the repairs or replacement, regardless of improvements on lands where the repairs or replacement are required.
- 4) Work found or reported to be unacceptable or that requires correction shall be remedied by the Owner/Developer or Contractor promptly after notification by the District Representative.
- 5) Acceptance procedures will not commence until all unacceptable work has been corrected.

5.1.10 Construction Closeout

- 1) If not previously submitted during construction, Owner/Developer or Contractor shall submit copies of the following project records to the District Representative:
 - a. A copy of the final plat and any amendments as recorded with the El Paso County Colorado Clerk and Records Office.
 - b. Video sanitary sewer survey on each reach of sewer line installed.
 - c. All operating and maintenance manuals and items necessary for system operation.
 - d. Any items identified by the District Representative to be missing from the construction records.
 - e. As-built drawings and as-built survey data.
- 2) As-built drawings and as-built field survey shall include a stamped hardcopy by a Colorado PE and/or PLS, and a digital copy (AutoCAD and PDF formats) of the completed system improvements showing:
 - a. Actual rim and invert elevations of each manhole installed.
 - b. Actual horizontal location of each manhole.
 - c. Actual horizontal location of each sewer service line and clean out installed.

- d. Actual horizontal location of each water service line, valve box, and curb stop box installed.
- e. All water and sewer mains. Include line and curve tables for all reaches of curvilinear sewer and water mains.
- f. Insert coordinate listing tables for all horizontal and vertical coordinates with the following information:
 - i) All horizontal survey data shall utilize and be submitted to the District in coordinates listed in [Table 2](#).
 - ii) For each curb stop box and sewer service line cleanout:
 - Lot numbers or unit numbers.
 - Water and sewer descriptors, such as “water curb stop”, “sewer service clean out”.
 - Horizontal dimensions from the front two (2) surveyed property pins.
 - Northing and Easting, Latitude and Longitude of each point.
 - iii) For each water valve, ARV vault, PRV vault, hydrant, PI, tee, manhole, and all other appurtenances:
 - Water and sewer descriptors (e.g., “water valve”, “sewer manhole”).
 - Northing and Easting, Latitude and Longitude of each point.

5.1.11 Conditional Acceptance

1) General

The system improvements will qualify for Conditional Acceptance by the District provided all the construction procedures and construction close-out requirements have been fulfilled to the satisfaction of the District.

2) Process

- a. The Developer/Owner or Contractor may request a preliminary inspection of the system improvements upon completion of construction. The inspection will be performed by District representative(s), in the presence of the Contractor and the Developer/Owner and others as appropriate.
- b. A list will be prepared of any items requiring correction and delivered to the Contractor and/or Developer/Owner.
- c. Contractor and/or Developer/Owner will correct all items on the list and schedule a Conditional Acceptance inspection.
- d. Contractor or Developer/Owner will prepare and submit copies of the project close out documentation per the construction procedures and construction close-out requirements, listed in [Section 5.1.10](#).
- e. Developer/Owner shall submit a warranty which meets the requirements listed in [Section 2.4.5](#) for maintenance obligations of the System Improvements.

- i) The minimum amount of time that the warranty will be in effect is 1 year from the date of Conditional Acceptance.
 - f. Developer/Owner and/or Contractor shall pay any remaining fees or charges then due to the District in connection with the system improvements, such as construction fees not covered by any initial deposit or subsequent deposits.
 - g. Developer/Owner and/or Contractor shall pay any remaining fees or charges then due to the District in connection with inclusion, offsite facilities, supplemental water, or other fees owed to the District as a result of the development.
- 3) Conditional Acceptance Certificate
 - a. Upon receipt and evaluation of all construction close-out documentation and any other documentation requested by the District as being necessary in determining the operational readiness of the system improvements, the District will issue a written Conditional Acceptance Certificate to the Developer/Owner.
 - b. The Conditional Acceptance Certificate may include a list of conditions that will need to be completed/adhered to during the maintenance period and prior to Final Acceptance of the system improvements.
 - c. The District will not accept tap applications or permit taps or service connections to the system improvements until all system improvements have been conditionally accepted in writing by the District.
 - d. The District will refund any remaining unused construction fee deposits to Developer/Owner.
- 4) Maintenance and Repair/Cure of Defects
 - a. Until Final Acceptance of the system improvements, the Developer/Owner shall be responsible for all maintenance, repair, and/or replacement of the system improvements.
 - b. The Developer/Owner shall protect the system improvements and perform all routine maintenance thereon to keep it in good repair and operating condition.
 - i) Developer/Owner shall repair or replace any part or parts thereof damaged from lot grading, street construction, paving, other utility installation, or vehicular traffic.
 - ii) Developer/Owner shall correct any soil subsidence or erosion which the District determines occurred in connection with, or as a result of, construction of the system improvements.
 - c. The Developer/Owner shall correct, repair, or replace any part or parts of the system improvements which the District reasonably determines were not constructed in conformity with the Rules and Regulations, System Specifications, approved plans, construction notes, or which the District determines to be defective, of poor or unworkmanlike quality, or otherwise not in conformity with any applicable warranty.

- d. Cure of defects by the Developer/Owner shall be administered and enforced under the Rules and Regulations.

5.1.12 Final Acceptance

1) General

- a. The system improvements will qualify for final acceptance by the District, provided all conditions and requirements of the Conditional Acceptance Certificate have been fulfilled to the satisfaction of the District.
- b. Until a Final Acceptance Certificate has been issued by the District, the Developer/Owner will continue to warranty the system improvements.
 - i) The minimum amount of time that the warranty will be in effect is 1 year from the date of Conditional Acceptance.

2) Final Acceptance Process

- a. When the system improvements are complete and ready for final inspection and acceptance, a final inspection will be requested by Developer/Owner.
- b. The final inspection may be initiated by written or verbal request from the Developer/Owner to the District. The Developer/Owner and the District will agree on a date and time for the final inspection when representatives of the Developer/Owner, the Contractor, and District will be present.
- c. A final inspection of system improvements will be performed and a list of items requiring correction, repair or replacement will be developed by the District and transmitted to the Developer/Owner.
- d. The Developer/Owner will make all repairs, corrections and replacements noted on the list.
- e. The District will verify that all items have been satisfactorily completed and issue a final acceptance certificate executed by the Developer/Owner and the District.
- f. Developer/Owner shall submit the following for District approval:
 - i) A verified statement of the actual cost of the system improvements, itemized as the District may require.
 - ii) Any and all deeds, bills of sale, or other conveyance instruments necessary to bestow title to all component parts of the system improvements in the District, with warranties of title as required by the District.
 - iii) All drawings, maps, and construction notes pertaining to any changes in the system improvements made during the period of Conditional Acceptance, together with any updates/modifications to the as-built drawings and/or as-built survey.
 - iv) Payment of all sums due, if any, to the District from the Developer/Owner on account of the system improvements.

APPENDIX A

STANDARD CONSTRUCTION SPECIFICATIONS

SECTION 00 01 10 - TABLE OF CONTENTS

DIVISION 01 - GENERAL REQUIREMENTS

- 01 30 ADMINISTRATIVE REQUIREMENTS**
 - 01 30 00 Administrative Requirements

- 01 40 QUALITY REQUIREMENTS**
 - 01 40 00 Quality Requirements
 - 01 42 13 Abbreviations and Acronyms
 - 01 42 19 Reference Standards

- 01 60 PROJECT REQUIREMENTS**
 - 01 60 00 Project Requirements

- 01 70 EXECUTION AND CLOSEOUT REQUIREMENTS**
 - 01 70 00 Execution and Closeout Requirements

DIVISION 03 – CONCRETE

- 03 30 CAST IN PLACE CONCRETE**
 - 03 30 00 Concrete

- 03 60 GROUTING**
 - 03 60 00 Grout

DIVISION 07 – THERMAL AND MOISTURE PROTECTION

- 07 10 DAMPROOFING AND WATERPROOFING**
 - 07 11 13 Bituminous Damproofing

DIVISION 31 – EARTHWORK

- 31 00 EARTHWORK**
 - 31 00 00 Earthwork

DIVISION 33 – UTILITIES

- 33 10 WATER UTILITIES**
 - 33 11 00 Water Utility Distribution Piping
 - 33 12 00 Water Utility Distribution Equipment
 - 33 13 00 Disinfection of Water Utility Distribution
 - 33 19 00 Water Utility Structures

- 33 30 SANITARY SEWERAGE UTILITIES**
 - 33 31 00 Sanitary Utility Sewerage Piping
 - 33 39 00 Sanitary Utility Sewerage Structures

01 30 00
ADMINISTRATIVE REQUIREMENTS

PART 1 GENERAL**1.1 SUMMARY**

- A. Section Includes
 - 1. Project meetings.
 - 2. Submittals schedule.
 - 3. Submittal requirements
 - 4. Shop drawings, product data, and samples.
- B. Related Sections
 - 1. All Sections of the Standard Construction Specifications.

1.2 PROJECT MEETINGS

- A. Pre-construction meeting
 - 1. Developer/Owner is required to contact the District for a pre-construction meeting after the construction documents are approved and prior to any Work included in these Standard Specifications.
- B. Progress Meetings
 - 1. Progress meetings are not required, but may be requested by the District Engineer, Contractor, or Owner at any time during the construction stage.

1.3 SUBMITTALS SCHEDULE

- A. Shop drawings and product data will only be reviewed after approval of the Construction Plans by the District.
- B. Shop drawings and product data for all substitutions must be reviewed and approved prior to installation of products.
- C. Submittal of complete project record documents must be reviewed and approved prior to issuance of conditional acceptance.
 - 1. Conditional acceptance of public main infrastructure is required prior to issuance of tap permits for services connected thereto.

1.4 SHOP DRAWINGS, PRODUCT DATA, AND SAMPLES

- A. Shop Drawings
 - 1. Drawings shall be presented in a clear and thorough manner.
 - 2. Identify details by reference to sheet and detail, schedule or detail numbers shown on Contract Drawings.

3. Identify equipment by reference to equipment name and tag number shown on Construction Plans.
 4. Scale and Measurements: Make drawings accurate to a scale with sufficient detail to show the kind, size, arrangement and function of component materials and devices.
 5. Minimum sheet size: Letter Size.
 6. Fabrication drawing size: Tabloid or ANSI – D.
- B. Product Data
1. Preparation
 - a. Clearly mark each copy to identify pertinent products or models submitted for review.
 - b. Identify equipment by reference to equipment name and tag number.
 - c. Catalog cut sheets: Cross-out or delete irrelevant data.
 - d. Show performance characteristics and capacities.
 - e. Show dimensions and clearances required for installation and maintenance.
 - f. Show wiring or piping diagrams and controls.
 - g. Show external connections, anchorages, and supports required.
 2. Manufacturer's standard schematic drawings and diagrams
 - a. Modify drawings and diagrams to delete information which is not applicable to the Work by crossing out or omitting irrelevant data.
 - b. Supplement standard information to provide information specifically applicable to the Work.
 3. Certificate of Compliance
 - a. Provided by manufacturer or supplier in lieu of submittal data required.
 - b. Certifies that product data or item identified in certificate is in total compliance with the specifications.
 - c. Specifically identifies project name and that there is no deviation from specifications.
 - d. Identify equipment by reference to equipment name and tag number.
 - e. Identify limits of equipment, materials or work provided.
 - f. Provide for specific product data or item only as indicated herein.
- C. Contractor Responsibilities
- a. Review shop drawings and product data prior to submission for accuracy and completeness of each submission.
 - b. Determine and verify:
 - 1) Field measurements.
 - 2) Field construction criteria.
 - 3) Catalog numbers and similar data.
 - 4) Conformance with specifications.

- c. Verify that each submittal conforms in all respects with specified requirements of the Work and the Standard Specifications with respect to means, methods, techniques, sequences, and operations of construction, and safety precautions and programs incidental thereto.
- d. Make submissions promptly in accordance with Construction Schedule, and in such sequence as to cause no delay in the Work or in the work of any other Contractor.
- e. Notify the District in writing, at time of submission, of any deviations in the submittals from specifications.
 - 1) Identify and tabulate all deviations in transmittal letter.
 - 2) Indicate essential details of all changes proposed, including modifications to other facilities that may be a result of the deviation.

D. Submission Requirements

- 1. Make submissions far enough in advance of scheduled dates for installation to provide time required for reviews, for securing necessary approvals, for possible revisions and resubmissions, and for placing orders and securing delivery.
- 2. Allow a minimum of 14 calendar days for review by the District following receipt of submission the District.
 - a. Time required to mail submissions or resubmissions is not considered a part of the review period.
- 3. Consecutively number all submissions.
 - a. Assign a unique number to include all shop drawings, product data and other information required for individual specification sections
 - b. Each specification section may still have more than one submittal number for later submissions (i.e., Preliminary O&M Manuals, Final O&M Manuals, etc.).
- 4. Number of Submittals Required
 - a. Shop Drawings and Product Data
 - 1) 1 Digital Copy via E-mail, 1 Digital Copy on Disc, or 2 hard Copies via Mail or Hand Delivery
- 5. Accompany each submission with a letter of transmittal showing all information required for identification and checking.
 - a. Submittal number.
 - b. Date of submission.
 - c. Project title.
 - d. The names of the Contractor, Supplier, and Manufacturer.
 - e. Identification of the product, with the specification section number.
 - f. Field dimensions, clearly identified as such.
 - g. Relation to adjacent or critical features of the Work or materials.
 - h. Applicable standards, such as ASTM or Federal Specification numbers.

- i. Identification of deviations from Construction Documents.
 - j. Identification of revisions on resubmissions.
 6. Submittal Log
 - a. Maintain an accurate submittal log for duration of the Work showing current status of all submissions.
 - b. Show submittal number, section number, section title, submittal description dates and disposition of submittal.
 - c. Make submittal log available to the District for review upon request.
 7. Unless specified otherwise, make submissions in groups to facilitate efficient review and approval.
 - a. Include all associated items from individual specification sections to assure that all information is available for checking each item when it is received.
 - b. Submit a complete initial submittal including all components when an item consists of components from several sources.
 - c. The District will not be responsible for delays due to poorly organized or incomplete submissions.
 8. Contractor may require subcontractors to provide drawings, setting diagrams and similar information to help coordinate the Work but that information will not be reviewed by the District.
- E. Disposition of Submittals
 1. "Approved As Submitted": Approved with No Exceptions Noted.
 - a. No corrections or comments noted on submittal or in transmittal letter.
 - b. Issues or miscellaneous comments pertaining to other related items of the Work may be included in transmittal letter
 2. "Exceptions Noted": Approved with Corrections Noted.
 - a. Comply with corrections or comments as noted on submittal and in transmittal letter.
 3. "Revise And Resubmit": Incorrect or Specific Information Still Required.
 - a. Submittal is either: incorrectly annotated; specific comments need to be addressed and incorporated in resubmittal; and/or additional information may be required as noted in transmittal letter.
 - b. Submitted information may not include or address specific item required per the specification as identified in transmittal letter
 - c. Specific information related to an identified item may be required before final approval of submittal.
 - d. Resubmission of entire submittal may be required or resubmission of specific item may be required as identified in transmittal letter.
 4. "Rejected":
 - a. Product, shop drawing, or sample submitted does not comply with provisions of Contract Documents as noted in transmittal letter.

5. "Receipt Acknowledged": For Reference Purposes Only or for Record Copy.
 - a. Detailed review and comment by District not required.
 - b. Resubmission not required.
- F. Resubmission Requirements
 1. Make any corrections or changes in submittals required by the District and resubmit until approved.
 2. Transmit each resubmission under new letter of transmittal. Use number of original submittal followed directly by a capital letter corresponding to the number of times a submittal is resubmitted (i.e., 1, 1A, 1B, etc.).
 3. Shop Drawings and Product Data:
 - a. Revise initial drawings or data and resubmit as specified for the initial submittal.
 - b. Indicate any changes which have been made other than those requested by the District.
- G. District Responsibilities
 1. Review submittals within a reasonable amount of time.
 2. Review drawings and data submitted only for general conformity with Construction Documents and Specifications.
 - a. District's review of drawings and data returned marked "Approved As Submitted" or "Exceptions Noted" indicates general conformance of all dimensions, quantities, and details of material, equipment device or items shown.
 - b. District's review does not relieve Contractor of responsibility for errors, omissions or deviations nor responsibility for compliance with the Construction Documents or Specifications.
 - c. District's review shall not extend to means, methods, techniques, construction sequencing, operations of construction, and safety precautions and programs.. No information regarding these items will be reviewed whether or not included in submittals
 3. Any shop drawing or related submittal that comprises a deviation to the Construction Documents or Specifications will not be considered unless Contractor advises the District in writing and is acknowledged by the District in writing.
 - a. Consider and review only those deviations clearly identified as such in submittal and tabulated in the Letter of Transmittal.
 4. Return all copies of submittals reviewed to the Contractor including information received directly from suppliers, manufacturers and subcontractors.
 5. Return all copies of information submitted but not reviewed to the Contractor that was not related to the Work in these Specifications.
 - a. The District will not review unnecessary shop drawings or product data except by special arrangement.

PART 2 PRODUCTS

Not Used

PART 3 EXECUTION

Not Used

END OF SECTION

01 40 00
QUALITY CONTROL REQUIREMENTS

PART 1 GENERAL**1.1 SUMMARY**

- A. Section Includes
 - 1. Submittal requirements.
 - 2. Quality Assurance/Control of Installation Requirements.
 - 3. Laboratory services, qualifications, duties, and limitations of authority. Contractor's responsibilities.
 - 4. Shop testing.
 - 5. Field testing.
 - 6. Field test and services schedule.

- B. Related Sections
 - 1. All Sections of the Standard Construction Specifications.

1.2 REFERENCES

- A. Conform to Reference Standards by current date of issue on Construction Documents.

- B. Conform to latest Standard Specifications of the District by current date on Construction Documents.

- C. Where specified Reference Standards conflict with Construction Documents, request clarification from District before proceeding.

1.3 SUBMITTALS

- A. Provide copies of written reports for materials, products, or test as scheduled at the end of this section. Reference each report by respective section number.

- B. Laboratory qualifications
 - 1. Provide statement of qualifications from testing firm and testing firm personnel for review and acceptance by the District.

- C. Laboratory test reports
 - 1. Provide written reports of each test and inspection to the District. Each report shall include:
 - a. Date issued.
 - b. Project title and number.
 - c. Testing laboratory name, address, and telephone number.
 - d. Name and signature of laboratory inspector.

- e. Date and time of sampling or inspection.
 - f. Record of temperature and weather conditions.
 - g. Date of test.
 - h. Identification of product and specification section.
 - i. Location of sample or test in the Project.
 - j. Type of inspection or test.
 - k. Results of tests and compliance with construction Documents.
 - l. Interpretation of test results when requested by the District.
- D. Shop test reports: Provide reports detailing results of tests and certification from manufacturer to verify compliance with specifications.
- E. Field test reports: Provide reports detailing results of the tests. Indicate compliance or non-compliance with Construction Documents and District Specifications. Identify corrective action for materials and equipment which fails to pass field tests.

1.4 QUALITY ASSURANCE/CONTROL OF INSTALLATION

- A. Monitor quality control over suppliers, manufacturers, products, services, site conditions, and workmanship to produce Work of specified quality.
- B. Comply fully with manufacturer's instructions, including each step in sequence.
- C. Should manufacturer's instructions conflict with Construction Documents, request clarification from District before proceeding.
- D. Comply with specified standards as a minimum quality for the Work except when more stringent tolerances, codes, or specified requirements indicate higher standards or more precise workmanship.

1.5 INSPECTION AND TESTING LABORATORY SERVICES

- A. Developer/Owner or Contractor will employ and pay for the services of an independent testing laboratory to perform specified laboratory testing of materials.
1. Contractor shall cooperate with the laboratory to facilitate the execution of its required services.
 2. Employment of the laboratory shall in no way relieve Contractor's obligations to perform the Work of the Contract.
- B. Retesting required because of non-conformance to specified requirements may be performed by the same independent firm unless otherwise instructed by the District.

1.6 QUALIFICATION OF LABORATORY

- A. Ability to perform all tests to determine compliance with Construction Documents and Specifications by an independent commercial testing firm acceptable to the District.
- B. Staffed with experienced technicians, properly equipped and fully qualified to perform tests in accordance with specified standards.
- C. Meet basic requirements of ASTM E 329, "Standards of Recommended Practice for Inspection and Testing Agencies for Concrete and Steel as Used in Construction" as applicable.
- D. Authorized to operate in the State in which the Project is located.
- E. Testing equipment:
 - 1. Calibrated at reasonable intervals by devices of accuracy traceable to either:
 - a. National Bureau of Standards.
 - b. Accepted values of natural physical constants.

1.7 LABORATORY DUTIES

- A. Perform specified inspections, sampling, and testing of materials and methods of construction.
 - 1. Comply with specified standards.
 - 2. Ascertain compliance of materials with requirements of Construction Documents and District Specifications.
- B. Promptly notify District and Contractor of observed irregularities or deficiencies of work or products.

1.8 LIMITATIONS OF AUTHORITY OF TESTING LABORATORY

- A. Laboratory is not authorized to:
 - 1. Release, revoke, alter or enlarge on requirements of Construction Documents or Specifications.
 - 2. Approve or accept any portion of the Work.
 - 3. Laboratory employees shall not perform any duties of the Contractor.

1.9 CONTRACTOR RESPONSIBILITIES

- A. Cooperate with laboratory personnel and provide access to Work.
- B. Secure and deliver to the laboratory adequate quantities of representative samples of materials proposed to be used and which require testing.

- C. Provide to the laboratory the preliminary design mix proposed to be used for concrete and other material mixes which require control by the testing laboratory.
- D. Furnish copies of product test reports as required.
- E. Furnish incidental labor and facilities.
 - 1. To provide access to Work to be tested.
 - 2. To obtain and handle samples at the project site or at the source of the product to be tested.
 - 3. To facilitate inspections and tests.
 - 4. For storage and curing of test samples.
 - 5. Notify District and independent firm 24 hours prior to expected time for operations requiring services to allow for scheduling of tests and laboratory assignment of personnel.
 - 6. Make arrangements with independent firm and pay for additional samples and tests required for Contractor's use.

1.10 SHOP TESTS

- A. Developer/Owner or Contractor will coordinate and pay all costs associated with specified shop tests of equipment, including retesting of items which fail original tests specifically identified in the technical specifications.
- B. Where the specifications call for a shop test to be witnessed by a representative of the District, notify District not less than 14 days prior to the scheduled test date.

1.11 FIELD TESTING

- A. Developer/Owner or Contractor shall pay all costs associated with field testing of materials and equipment as required in respective sections of the specifications.
- B. Provide all required materials, labor, equipment, water, and power required for testing.
- C. Perform all tests in presence of District and submit one copy of field test results to District per the requirements of the Record Documents.

1.12 FIELD TESTING AND SERVICES SCHEDULE

- A. Testing laboratory services shall be provided for, but shall not be limited to, the following:
 - 1. 31 00 00 – Earthwork
 - a. Gradations, Sieve Analysis, Proctors with Optimum Moisture Content
 - 2. 03 30 00 – Concrete
 - a. Mix Design, Cement, Compressive Strength, Admixtures

Field testing shall be provided for, but shall not be limited to, the following:

3. 03 30 00 – Concrete
 - a. Air Content, Slump, Compressive Strength
4. 31 00 00 – Earthwork
 - a. Compaction, Moisture Content
5. 33 11 00 – Water Utility Distribution Piping
 - a. Hydrostatic Pressure Testing
6. 33 12 00 – Water Utility Distribution Equipment
 - a. Hydrostatic Pressure Testing
7. 33 13 00 – Disinfection of Water Utility Distribution
 - a. Bacteriological Testing
8. 33 31 00 – Sanitary Utility Sewerage Piping
 - a. Air Pressure Testing, Deflection Testing, TV Inspection
9. 33 39 00 – Sanitary Sewerage Utility Structures
 - a. Vacuum tests

PART 2 PRODUCTS

Not Used

PART 3 EXECUTION

Not Used

END OF SECTION

01 42 13
ABBREVIATIONS AND ACRONYMS

PART 1 GENERAL

1.1 SUMMARY

- A. Section includes
1. Abbreviations for organizations and standards.
 2. Other abbreviations and symbols.

1.2 ORGANIZATIONS AND STANDARDS

AA	Aluminum Association
AAMA	Architectural Aluminum Manufacturers Association
AASHTO	American Association State Highway and Transportation Officials
ACI	American Concrete Institute
AFBMA	Antifriction Bearing Manufacturers Association
AGA	American Gas Association
AGMA	American Gear Manufacturers Association
AI	Asphalt Institute
AISC	American Institute of Steel Construction
AISI	American Iron and Steel Institute
AMCA	Air Moving and Conditioning Association
ANSI	American National Standards Institute
APA	American Plywood Association
ASCE	American Society Civil Engineers
ASHRAE	American Society Heating, Refrigerating and Air Conditioning Engineers
ASME	American Society Mechanical Engineers
ASTM	American Society for Testing and Materials
AWS	American Welding Society
AWPA	American Wood Products Association or American Wood Preservers Association
AWPB	American Wood Preserver's Board
AWWA	American Water Works Association
CDPHE	Colorado Department of Public Health and Environment
CDOT	Colorado Department of Transportation
CIPRI	Cast Iron Pipe Research Institute
CISPI	Cast Iron Soil Pipe Institute
CMAA	Crane Manufacturer's Association of America
CRSI	Commercial Standard
FM	Factory Mutual
FS	Federal Specification

HMI	Hoist Manufacturer's Institute
IEEE	Institute Electrical and Electronics Engineers
IFI	Industrial Fasteners Institute
IPCEA	Insulated Power Cable Engineers Association
MIL	Military Specification
NAAMM	National Association Architectural Metals Manufacturers
NEC	National Electric Code
NEMA	National Electrical Manufacturers Association
NFPA	National Fire Protection Association or National Forest Products Association
NSF	National Sanitation Foundation Testing Laboratory
OSHA	Occupational Safety and Health Administration
PCI	Prestressed Concrete Institute
PS	Product Standard
SAE	Society of Automotive Engineers
SCPRF	Structural Clay Products Research Foundation
SJI	Steel Joist Institute
SPI	Society of the Plastics Industry
SSPC	Steel Structures Painting Council
UL	Underwriter's Laboratories
USBS	U.S. Bureau of Standards
USBR	U.S. Bureau of Reclamation

1.3 OTHER ABBREVIATIONS AND SYMBOLS

AC	alternating current
Amp	ampere
AV	air vent
AWG	American wire gage
BIL	basic impulse level
BCY	bank cubic yard
C	centigrade or Celsius
CIP	cure-in-place

cu	cubic
DC	direct current
Diam	diameter
F	Fahrenheit
ft (')	foot
ga	gage
gal	gallon
GSP	galvanized steel pipe
hp	horsepower
Hz	hertz
hr(s)	hour(s)
in(“)	inch
IPS	iron pipe size
kV	kilovolt
kVA	kilovolt ampere
lb	pound
mA	milliampere
min	minimum
max	maximum
M	meter
mm	millimeter
MG	million gallons
MH	manhole
NPT	national pipe thread
PVC	polyvinyl chloride
sq	square
lf	lineal foot
vf	vertical foot
yd	yard
o	degree
%	percent

END OF SECTION

01 42 19
REFERENCE STANDARDS

PART 1 GENERAL**1.1 SUMMARY**

- A. Section includes
 - 1. Quality assurance.
 - 2. Schedule of references.

1.2 QUALITY ASSURANCE

- A. For products or workmanship specified by association, trade, Federal Standards, or other consensus standards, comply with requirements of the standard, except when more rigid requirements are specified or are required by applicable codes.
- B. Conform to reference standard by date of issue current on approved Construction Plans.
- C. Should specified reference standards conflict with Construction Documents, request clarification from District before proceeding.

1.3 SCHEDULE OF REFERENCES

- AA Aluminum Association
1400 Crystal Drive, Suite 430
Arlington, VA 22202
www.aluminum.org
- AABC Associated Air Balance Council
2401 Pennsylvania Avenue NW, Suite 330
Washington, DC 20037
www.aabc.com
- AASHTO American Association of State Highway and Transportation Officials
444 N. Capitol St., NW, Suite 249
Washington, DC 20001
www.aashto.org
- ABMA American Bearing Manufacturers Association
1001 N. Fairfax Street, Suite 500
Alexandria, VA 22314
www.americanbearings.org
- ACA American Coatings Association
901 New York Avenue NW, Suite 300 West
Washington, DC 20001
www.paint.org
- ACGIH American Conference of Governmental Industrial Hygienists
1330 Kemper Meadow Dr., Suite 600

	Cincinnati, OH 45240 www.acgih.org
ACI	American Concrete Institute 38800 Country Club Dr Farmington Hill, MI 48331 www.concrete.org
ACPA	American Concrete Pipe Association 5605 N MacArthur Blvd #340 Irving, TX 75038 www.concretepipe.org
	Air Diffusion Council 1901 N. Roselle Rd Schaumburg, IL 60195 www.flexibleduct.org
ADSC	The International Association of Foundation Drilling 950 E State Hwy 114 Ste 160 Southlake, TX 76092 www.adsc-iafd.com
AF&PA	American Forest and Paper Association 1101 K Street, NW, Suite 700 Washington, DC 20005 www.afandpa.org
AFSA	American Fire Sprinkler Association, Inc. 12750 Merit Drive, Suite 350 Dallas, Texas 75251 www.firesprinkler.org
AFSS	American Filtration And Separation Society 252 N. Washington St., Suite A Falls Church, VA 22046 www.afssociety.org
AGC	Associated General Contractors Of America 2300 Wilson Blvd., Suite 300 Arlington, VA 22201 www.agc.org
AHA	American Hardboard Association 1210 West Northwest Highway Palatine, IL 60067 www.hardboard.org
AHRI	Air-Conditioning, Heating, and Refrigeration Institute 2311 Wilson Blvd, Suite 400 Arlington, VA 22201 www.ahrinet.org
AI	Asphalt Institute 2696 Research Park Drive Lexington, KY 40511 www.asphaltinstitute.org
AIA	American Institute of Architects

	1735 New York Ave., Nw Washington, DC 20006 www.aia.org
AICE	American Institute Of Chemical Engineers 120 Wall Street, FL 23 New York, NY 10005 www.aiche.org
AISC	American Institute of Steel Construction 130 East Randolph, Suite 2000 Chicago, IL 60601 www.aisc.org
AISI	American Iron and Steel Institute 25 Massachusetts Avenue, NW Suite 800 Washington, DC 20001 www.steel.org
AITC	American Institute of Timber Construction 6980 SW Varns St Tigard, OR 97223 www.aitc-glulam.org
AMCA	Air Movement and Control Association International, Inc. 30 W. University Dr. Arlington Heights, IL 60004-1893 www.amca.org
ANSI	American National Standards Institute 1899 L Street, NW 11 TH Floor Washington, DC 20036 www.ansi.org
APA	The Engineered Wood Association 7011 S. 19th Street Tacoma, WA 98466 www.apawood.org
APFA	American Pipe Fittings Association 201 Park Washington Ct Falls Church, VA 22046 www.thepipefittings.com
API	American Petroleum Institute 1220 L Street. NW Washington, DC 20005-4070 www.api.org
AREMA	American Railway Engineering and Maintenance-of-Way Association 4501 Forbes Blvd., Suite 130 Lanham, Maryland 20706 www.arena.org
ARRA	Asphalt Recycling and Reclaiming Association 800 Roosevelt Road, Building C-312 Glen Ellyn, IL 60137 www.ara.org

- ASCE American Society of Civil Engineers
World Headquarters
1801 Alexander Graham Bell Dr.
Reston, VA 20191-4400
www.asce.org
- ASHRAE American Society of Heating, Refrigerating and Air-Conditioning Engineers
180 Technology Parkway
Peachtree Corners, Georgia 30092
www.ashrae.org
- ASME American Society of Mechanical Engineers
2 Park Ave.
New York, NY 10016-5990
www.asme.org
- ASNT American Society for Nondestructive Testing Inc.
1711 Arlingate Ln.
Columbus, OH 43228-0518
www.asnt.org
- ASSE American Society of Sanitary Engineering
18927 Hickory Creek Dr Ste 220
Mokena, IL 60448
www.asse-plumbing.org
- ASTM American Society of Testing Materials International
100 Barr Harbor Dr.
West Conshohocken, PA 19428-2959
www.astm.org
- AWI Architectural Woodwork Institute
Potomac Falls, VA
www.awinet.org
- AWPA American Wood Protection Association
3000 Galleria Cir #705
Hoover, AL 35244
www.awpa.com
- AWS American Welding Society
8669 NW 36 Street, Suite 130
Miami, FL 33166
www.aws.org
- AWWA American Water Works Association
6666 W. Quincy Ave.
Denver, CO 80235
www.awwa.org
- BHMA Builders Hardware Manufacturers Association
355 Lexington Ave., 15th Floor
New York, NY 10017
www.buildershardware.com
- BIA Brick Industry Association

	12007 Sunrise Valley Drive, Suite 430 Reston, VA 20191 www.gobrick.com
CAGI	Compressed Air and Gas Institute 1300 Sumner Cleveland, OH 44115 www.cagi.org
CDA	Copper Development Association, Inc. 7918 Jones Branch Dr, Suite 30 McLean, Virginia 22102 www.copper.org
CDPHE	Colorado Department of Public Health and Environment 4300 Cherry Creek Dr., S. Denver, CO 80222 www.cdphe.colorado.gov
CDOT	Colorado Department of Transportation 430 Cherry Creek Drive South Denver, CO 80246 www.dot.state.co.us
CGA	Compressed Gas Association 8484 Westpark Drive, Suite 220 McLean, Virginia 22102 www.cganet.com
CI	Chlorine Institute 1300 Wilson Blvd., Suite 525 Arlington, VA 22209 www.cl2.com
CISCA	Ceilings and Interior Systems Construction Association 1010 Jorie Blvd, Suite 30 Oak Brook, IL 60523 www.cisca.org
CISPI	Cast Iron Soil Pipe Institute 2401 Fieldcrest Drive Mundelein, IL 60060 www.cispi.org
CLFMI	Chain Link Fence Manufacturers Institute 10015 Old Columbia Rd. Suite B215 Columbia, MD 21046 www.chinlinkinfo.org
CRI	Carpet and Rug Institute P.O. Box 2048 Dalton, GA 30722-2048 www.carpet-rug.com
CRSI	Concrete Reinforcing Steel Institute 933 N. Plum Grove Rd. Schaumburg, IL 60173-4758 www.crsi.org

- CSI The Construction Specifications Institute
123 North Pitt Street, Suite 450
Alexandria, VA 22314
www.csiresources.org
- Cedar Shake and Shingle Bureau
P.O. Box 1178
Sumas, WA 98295
www.cedarbureau.org
- CTI Cooling Technology Institute
3845 Cypress Creek Parkway, Suite #420
Houston, TX 77090
www.coolingtechnology.org
- DASMA Door and Access Systems Manufacturers Association International
1300 Summer Avenue
Cleveland, OH 44115-2851
www.dasma.com
- DHA Decorative Hardwood Association
42777 Trade West Drive
Sterling, VA 20166
www.decorativehardwoods.org
- DHI The Door and Hardware Institute
2001 K Street NW, 3rd Floor North
Washington, DC 20006
www.dhi.org
- DIPRA Ductile Iron Pipe Research Association
P.O. Box 190306
Birmingham, AL 35244
www.dipra.org
- EIMA EIFS Industry Members Association
513 West Broad Street, Suite 210
Falls Church, VA 22046-3257
www.eima.com
- EJCDC Engineer's Joint Contract Documents Committee
American Consulting Engineers Council (www.acec.com)
1015 15th St., NW
Washington, DC 20005
www.ejcdc.org
- EJMA Expansion Joint Manufacturers Association
25 N. Broadway
Tarrytown, NY 10591
www.ejma.org
- EPA Environmental Protection Agency
1200 Pennsylvania Avenue, N.W.
Washington, DC 20460
www.epa.gov
- FAA Federal Aviation Administration
800 Independence Ave., SW
Washington, DC 20591

www.faa.gov

FGIA	Fenestration and Glazing Industry Alliance 1900 E Golf Rd, Suite 1250 Schaumburg, IL 60173 www.fgiaonline.org
NGA	National Glass Association 1945 Old Gallows Rd #750 Vienna, VA 22182 www.glass.org
	FM Global Corporate Headquarters 270 Central Ave Johnston, RI 02919 www.fmglobal.com
FS	Federal Specification Unit General Services Administration Federal Supply Service FSS Acquisition Management Center Environmental Programs and Engineering Policy Division Washington, DC 20406 www.gsa.gov
FSSA	Fire Suppression Systems Association 3601 East Joppa Road Baltimore, MD 21234 www.fssa.net
GA	Gypsum Association 962 Wayne Avenue, Suite 620 Silver Spring, MD 20910 www.gypsum.org
HI	Hydraulics Institute Morris Corporate Center I 300 Interpace Pkwy Suite A280 Parsippany, NJ 07054 www.pumps.org
HMMA	Hollow Metal Manufacturers Association Division of NAAMM 800 Roosevelt Rd. Bldg. C, Suite 312 Glen Ellyn, IL 60137 www.naamm.org/division/5
ICC	International Code Council 500 New Jersey Avenue, NW 6th Floor, Washington, DC 20001 www.iccsafe.org
IEEE	Institute of Electrical and Electronics Engineers, Inc. 3 Park Ave., 17 th Floor New York, NY 10016-5997 www.ieee.org
IES	Illuminating Engineering Society of North America 120 Wall Street, 17 th Floor

	New York, NY 10005 www.iesna.org
ILIAI	Indiana Limestone Institute of America 611 N Walnut Grove St suite s-217 Bloomington, IN 47405 www.iliai.com
IMI	International Masonry Institute BAC/IMI National Training Center 17101 Science Drive Bowie, MD 20715 www.imiweb.org
ISA	International Society of Arboriculture 270 Peachtree St NW, Suite 1900 Atlanta GA 30303 www.isa-arbor.com
KCMA	Kitchen Cabinet Manufacturers Association 1768 Business Center Drive, Suite 390 Reston, VA 20190 www.kcma.org
LPI	Lightning Protection Institute 333 Peterson Road, Suite F Libertyville, IL 60048 www.lightning.org
MBMA	Metal Building Manufacturers Association 1300 Sumner Ave. Cleveland, OH 44115-2851 www.mbma.com
MFMA	Maple Flooring Manufacturers Association 1425 Tri State Parkway, Suite 110 Gurnee, IL 60031 www.maplefloor.org
MIL	Military Standardization Documents Defense Automated Printing Service 700 Robbins Ave., Building 4D Philadelphia, PA 19111-5094 www.dodssp.daps.mil
MSS	Manufacturers Standardization Society of the Valve and Fittings Industry 127 Park St., NE Vienna, VA 22180-4602 www.msshq.com
NAAMM	National Association of Architectural Metal Manufacturers 8 South Michigan Ave., Suite 1000 Chicago, IL 60603 www.naamm.org
NAAMM	North American Association of Mirror Manufacturers (Division of GANA)

2945 Southwest Wanamaker Dr., Suite A
Topeka, KS 66614
www.glasswebsite.com

- NACE NACE International
15835 Park Ten Place
Houston, TX 77084
www.nace.org
- North American Insulation Manufacturers Association
11 Canal Center Plaza, Suite 103
Alexandria, VA 22314
www.insulationinstitute.org
- NAPHCC National Association of Plumbing-Heating-Cooling Contractors
180 S. Washington
Falls Church, VA 22040
www.phccweb.org
- NBGQA National Building Granite Quarries Association, Inc.
1220 L Street NW, Suite 100-167
Washington, DC 20005
www.nbgqa.com
- NCMA National Concrete Masonry Association
13750 Sunrise Valley Drive
Herndon, VA 20171
www.mcma.org
- NCRP National Council on Radiation Protection and Measurement
7910 Woodmont Ave., Suite 800
Bethesda, MD 20814-3095
www.ncrponline.org
- NEBB National Environmental Balancing Bureau
8575 Grovemont Circle
Gaithersburg, MD 20877
www.nebb.org
- NECA National Electrical Contractors Association
1201 Pennsylvania Ave. NW
Washington, D.C. 20004
www.necacconnection.org
- NELMA Northeastern Lumber Manufacturers Association
272 Tuttle Road
Cumberland, ME 04021
www.nelma.org
- NEMA National Electrical Manufacturers Association
1300 17th St N #900
Arlington, VA 22209
www.nema.org
- NETA International Electrical Testing Association
3050 Old Centre Ave., Suite 101
Portage, MI 49024
www.netaworld.org

NFPA	National Fire Protection Association 1 Batterymarch Park Quincy, Massachusetts 02169-7471 www.nfpa.org
NFRC	National Fenestration Rating Council 6305 Ivy Lane, Suite 140 Greenbelt, MD 20770 www.nfrc.org
NGA	National Glass Association 1945 Old Gallows Road, Suite 750 Vienna, VA 22182 www.glass.org
NGWA	National Ground Water Association 601 Dempsey Road Westerville, OH 43081 www.ngwa.org
NI	Nickel Development Institute 2525 Meridian Pkwy Durham, North Carolina 27713 www.nidi.org
NIBS	National Institute of Building Sciences 1090 Vermont Ave., NW, Suite 700 Washington, DC 20005-4905 www.nibs.org
NIST	National Institute of Standards and Technology 100 Bureau Dr, MS 2150 Gaithersburg, MD 20899-2150 www.nist.gov
NLA	National Lime Association 200 North Glebe Rd., Suite 800 Arlington, VA 22203 www.lime.org
NLGA	National Lumber Grades Authority Suite 303 – 409 Granville St Vancouver, BC V6C 1T2 CANADA www.nlga.org
NPCA	National Precast Concrete Association 1320 City Center Dr #200 Carmel, IN 46032 www.precast.org
NRCA	National Roofing Contractors Association O'Hare International Center 10255 W. Higgins Rd., Ste. 600 Rosemont, IL 60018 www.roofonline.org
NSF	NSF International

	789 N. Dixboro Road Ann Arbor, MI 48105 www.nsf.org
NSI	Natural Stone Institute 380 E Lorain Street, Oberlin Ohio 44074, US www.naturalstoneinstitute.org/
NSPE	National Society of Professional Engineers 1420 King St. Alexandria, VA 22314 www.nspe.org
NSWMA	National Waste and Recycling Association 1550 Crystal Drive, Suite 804 Arlington, VA 22202 www.wasterecycling.org
NTMA	National Terrazzo and Mosaic Association 209 N Crockett Street Fredericksburg, TX 78624 www.ntma.com
NUCA	National Utility Contractors Association 3925 Chain Bridge Road Fairfax, Virginia 22030 www.nuca.com
NWFA	National Wood Flooring Association 111 Chesterfield Industrial Blvd. Chesterfield, MO 63005 www.nwfa.org
PCA	Portland Cement Association 5420 Old Orchard Rd. Skokie, IL 60077 www.cement.org
PCI	Precast/Prestressed Concrete Institute 8770 W Bryn Mawr Avenue Chicago, Illinois 60631 www.pci.org
PDCA	Painting Contractors Association 2316 Millpark Drive Maryland Heights, MO www.pcapainted.org
PDI	Plumbing and Drainage Institute 800 Turnpike Street, Suite 300 North Andover, MA 01845 http://PDIonline.org
PEI	Petroleum Equipment Institute 6514 E 69th Street Tulsa, OK 74133 www.pei.org
PHTA	Pool and Hot Tub Alliance

	2111 Eisenhower Ave. Alexandria, VA 22314 www.phta.org
PLIB	Pacific Lumber Inspection Bureau 1010 South 336th Street, Suite 210 Federal Way, WA 98003 www.plib.org
PMI	Plumbing Manufacturers Institute 1750 Tysons Blvd. Ste. 1500 McLean, Virginia 22102 www.safeplumbing.org
PPFA	Plastic Pipe and Fittings Association 800 Roosevelt Rd., Bldg. C, Ste. 20 Glen Ellyn, IL 60137 www.ppfahome.org
PTI	Post Tensioning Institute 38800 Country Club Drive Farmington Hills, MI 48331 www.post-tensioning.org
RCSC	Research Council on Structural Connections www.boltcouncil.org
RIS	The Redwood Inspection Service 630 J Street Eureka, CA 9550 www.wvpa.org
	Southern Cypress Manufacturers Association 400 Penn Center Blvd., #530 Pittsburgh, PA 15235 www.cypressinfo.org
SDI	Steel Deck Institute 2661 Clearview Road, Suite 3 Allison Park, PA 15101 www.sdi.org
SDI	Steel Door Institute 30200 Detroit Rd. Cleveland, OH 44145-1967 www.steeldoor.org
FGIA	Fenestration and Glazing Industry Alliance 1900 E Golf Road Schaumburg, Illinois 60173, US www.fgiaonline.org
SJI	Steel Joist Institute 234 W Cheves Street Florence, South Carolina 29501 www.steeljoist.org
SMACNA	Sheet Metal and Air Conditioning Contractors' National Association 4201 Lafayette Center Dr. Chantilly, VA 20151-1209

	www.smacna.org
SPIB	Southern Pine Inspection Bureau 4555 Spanish Trail Pensacola, FL 32504 www.spib.org
SPRI	Single Ply Roofing Institute 465 Waverley Oaks Road, Suite 421 Waltham, MA 02452 www.spri.org
SSMA	Steel Stud Manufacturers Association 201 N Maple Grove Road, Suite 100 Boise, ID 83704 www.ssma.com
SSPC	Society for Protective Coatings 800 Trumbull Drive Pittsburgh, PA 15205 www.sspc.org
STI	Steel Tank Institute 944 Donata Court Lake Zurich, IL 60047 www.steeltank.com
SWI	Steel Window Institute 1300 Sumner Ave. Cleveland, OH 44115-2851 www.steelwindows.com
SWR	Sealant, Waterproofing and Restoration Institute 400 Admiral Blvd Kansas City, MO 64106 www.swrionline.org
TCNA	Tile Council of North America 100 Clemson Research Blvd. Anderson, SC 29625 www.tcnatile.com
TIA/EIA	Telecommunications Industry Association/ Electronic Industries Alliance 1310 North Courthouse Road, Suite 890 Arlington, VA 22201 www.tiaonline.org
TMS	The Masonry Society 105 S Sunset Street, Suite Q Longmont, CO 80501 www.masonrysociety.org
TPI	Truss Plate Institute 2670 Crain Highway, Suite 203 Waldorf, MD 20601 www.tpinst.org
	Turfgrass Producers International 444 E Roosevelt Road, Suite 346 Lombard, IL 60148

www.turfgrassod.org

- UL Underwriters Laboratories, Inc.
333 Pflingsten Rd.
Northbrook, IL 60062-2096
www.ul.com
- VMAA Valve Manufacturers Association of America
1625 K Street NW, Suite 325
Washington, DC 20006
www.vma.org
- WDMA Window and Door Manufacturers Association
2001 K Street NW, 3rd Floor North
Washington, D.C. 20006
www.wdma.org
- Intertek Testing Services by Warnock Hersey Mark
3210 American Drive
Mississauga, Ontario L4V 1B3
CANADA
www.intertek.com
- Woodwork Institute
1455 Response Road, Suite 110
Sacramento, CA 95815
www.wicnet.org
- WQA Water Quality Association
2375 Cabot Drive
Lisle, Illinois 60532-3696
www.wqa.org
- WWPA Western Wood Products Association
1500 SW 1st Avenue, Suite 870
Portland, OR 97201
www.wwpa.org

END OF SECTION

01 60 00
PROJECT REQUIREMENTS

PART 1 GENERAL**1.1 SUMMARY**

- A. Summary
 - 1. Common product requirements.
 - 2. Product options.
 - 3. Procedures for securing acceptance of proposed Substitutions for a product which is specified in Construction Documents by reference to one or more of the following:
 - a. Name of manufacturer
 - b. Name of supplier
 - c. Trade name
 - d. Catalog model number
- B. Request for Substitutions
- C. Related Sections
 - 1. All Sections of the Standard Construction Specifications.

1.2 GENERAL REQUIREMENTS

- A. This section applies to all materials and products provided.
- B. The requirements of detailed specifications sections take precedence over this section in the event of an apparent conflict.
- C. Provide all new materials and equipment, except as specified on the Construction Documents or in the Standard Construction Specifications.
- D. Except for materials as specifically indicated or specified, materials removed from the existing systems will not be used in the completed Work.
- E. Do not use materials or equipment for any purpose other than that for which it is designed and specified.

1.3 COMMON PRODUCT REQUIREMENTS

- A. Qualifications
 - 1. Manufacturer: Company specializing in manufacturing products specified with number of years documented experience as indicated within the respective section.

2. Installer: Materials shall be installed and placed in service by or under the guidance of qualified personnel having the knowledge and experience necessary to achieve the specified results.
- B. Quality Assurance
1. Observation of Performance Tests by District
 - a. All of the specified field testing and any retesting must be conducted in the presence of the District, and all costs will be charged to the Developer/Owner.
- C. Delivery, Storage, and Handling
1. Deliveries of products shall be in accordance with construction schedules, coordinate to avoid conflict with work conditions at the site.
 - a. Deliver products in undamaged condition, in manufacturer's original container or packaging, with identifying labels intact and legible.
 - b. Immediately on delivery, inspect shipments to ensure compliance with requirements of accepted Construction Documents and Product Submittals and those products are properly protected and undamaged.
 2. Provide equipment and personnel to handle products by methods to prevent soiling or damage to products or packaging.
- D. Preparation for Shipment
1. Package materials and equipment to facilitate handling and protect against damage during transit handling or storage.
 2. Tag or mark each item per the delivery schedule of the Shop Drawings.
 3. Include complete packing lists and bills of material with each shipment.
- E. Storage and Protection
1. Store immediately upon delivery.
 2. Store products in accordance with manufacturer's instructions, with seals and labels intact and legible.
 3. Store fabricated products above ground on blocking or skids to prevent soiling or staining.
 4. Cover products which are subject to deterioration with impervious sheet coverings, provide adequate ventilation to avoid condensation.
 5. Store loose granular materials in a well-drained area on solid surfaces to prevent mixing with foreign matter.
 6. Arrange storage in a manner to provide easy access for inspection. Make periodic inspections of stored products to ensure that products are maintained under specified conditions and free from damage or deterioration.
 7. Provide substantial coverings as necessary to protect installed products from damage from traffic and subsequent construction operations.

- F. Warranty
 - 1. All infrastructure materials and equipment installed for the Construction Project will have a minimum warranty period of one year after Conditional Acceptance, or until Final Acceptance has been granted, whichever is longer.

1.4 PRODUCT OPTIONS

- A. Products Specified by Reference Standards or by Description Only
 - 1. Where materials or products are specified by reference standards or description, any Product meeting those standards or descriptions may be used, provided, however the product(s) are demonstrated to meet such specifications through the product submittal process.
- B. Products Specified by Naming One or More Manufacturers
 - 1. Where materials and/or products are specified by naming one or more manufacturers and/or model number without a provision for substitution, only the material and/or products specified are approved for incorporation into the Work.
- C. Products Specified by Naming One or More Manufacturers with a Provision for Substitutions
 - 1. Submit a request for substitution for any manufacturer not named in accordance with this section:
 - a. Where materials and/or products are specified by name and/or model number, followed by words “Or accepted substitution”:
 - 1) The material and/or product specified by name establishes required standard of quality.
 - b. Materials and/or product proposed by Contractor to be used in lieu of materials and/or products so specified by name shall in all ways equal or exceed the qualities of named materials and/or products.
 - c. Where the phrase “or accepted substitution” occurs in the specifications, do not assume that materials, equipment, or products will be accepted as substitution unless item has been specifically reviewed and approved by the District.

1.5 SUBSTITUTIONS

- A. Written requests for substitution considered:
 - 1. Only when submitted by Contractor
- B. Substitutions will not be considered when they are indicated or implied on shop drawing or product data submissions, without separate written request.
- C. Substitutions may be considered when a Product becomes unavailable through no fault of Contractor:

1. Should the Contractor demonstrate to satisfaction of District that specified material or product was ordered in a timely manner and will not be available in time for incorporation into this Work, Contractor shall submit to the District such data on proposed substitute materials and/or product as are needed to help the District determine suitability of proposed Substitution.
- D. Document each request with complete data substantiating compliance of proposed Substitution.
1. A request constitutes a representation that Contractor:
 - a. Investigated proposed product and determined that it meets or exceeds quality level of specified product and that it will perform function for which it is intended.
 - b. Will provide same warranty for Substitution as for specified Product.
 - c. Will coordinate installation and make changes to other Work which may be required for Work to be complete.
 - d. Will provide a complete operating installation including any and all changes and additions in structure, piping, building, mechanical and electrical work, controls and accessories necessary to accommodate proposed Substitution.
 - e. Waives claims for additional costs or time extension which may subsequently become apparent.
- E. Procedure for Requesting Substitution
1. Submit request for substitution for consideration in a manner similar to provisions for submission requirements under Section 01 30 00.
 - a. Substitutions will be considered as "deviations" to the Construction Documents.
 - b. Submit with transmittal letter describing the deviation and justifications for accepting Substitution.
 - c. Submit shop drawings, product data, and certified test results attesting to proposed substitution equivalence.
 - d. Burden of proof is on the requestor.
 2. Limit each submittal request to one proposed substitution.
 3. Transmittal Contents:
 - a. Identification of proposed substitution.
 - 1) Manufacturer's name.
 - 2) Telephone number and representative contact name.
 - 3) Specification section or drawing reference of originally specified product including discrete name or tag number.
 - b. Manufacturer's literature clearly marked to show compliance of proposed Substitution with Construction Documents.
 - c. Itemized comparison of original product and proposed Substitution addressing characteristics including, but not necessarily limited to:

- 1) Size.
 - 2) Composition.
 - 3) Weight.
 - 4) Electrical or mechanical requirements.
 - 5) Installation and maintenance requirements.
 - d. Product experience:
 - 1) Location of previous projects utilizing product in similar situation per Construction Documents.
 - 2) Name and telephone number of persons knowledgeable of proposed product associated with referenced projects.
 - 3) Available field data and test reports associated with proposed product.
 - e. Samples:
 - 1) Provide in similar manner under provisions of Section 01 30 00 as requested by District.
 - 2) Provide full size sample if requested by District.
 - 3) Samples will be retained by District until substantial completion.
 - 4) Engineer is not responsible for loss or damage to samples.
4. Acceptance or Rejection
- a. Engineer will notify Contractor in writing of decision to accept or reject request for Substitution:
 - b. Decision of District is final
 - c. District will affix stamp and indicate acceptance of Substitution with the following or similar stamp:

ACCEPTED SUBSTITUTION
<p>This review was performed for general conformance with the design concept of the project and general compliance with the contract documents based on information provided by the contractor. Acceptance by engineer does not relieve contractor from responsibility for providing a complete operating installation including any and all changes and additions necessary to accommodate the substitution. Contractor is responsible for: dimensions to be confirmed and correlated at the jobsite; information that pertains solely to the fabrication processes or to the means, methods, techniques, sequences, and procedures of construction; coordination of the work of all trades; and for performing all work in a safe and satisfactory manner.</p>
Woodmoor Water and Sanitation District No. 1
DATE _____ BY _____

5. Engineer reserves the right to require proposed Substitution to comply with all aspects of specified product to secure design intent.
6. Substitutions will be rejected if:
 - a. Submission is not through or by the Contractor.
 - b. Requests for Substitution are not made in accordance submission procedures outlined herein.
 - c. Acceptance will require substantial revision of the original design as determined by District.
 - d. Substitution is not equal to original product specified or will not adequately perform intended function as determined by District.

PART 2 PRODUCTS

2.1 MATERIALS

- A. Suitable for the service conditions.

2.2 FABRICATION AND MANUFACTURE

- A. Design, fabricate, and assemble in accordance with the best modern manufacturing and shop practices.
- B. Manufacture parts to standard sizes and gauges.
- C. Two or more items of the same type shall be identical by the same manufacturer and interchangeable.

PART 3 EXECUTION

3.1 EXAMINATION

- A. Examine material for signs of pitting, rust decay, or other deleterious effects of delivery and storage. Do not install materials showing such effects. Replace damaged materials with identical new materials.

3.2 INSTALLATION

- A. Handle, install, connect, clean, condition and adjust products in accordance with the manufacturer's instructions and in conformity with the specified requirements.

3.3 OPERATIONAL REQUIREMENTS

- A. Perform all required adjustment tests, operation checks, or other startup activities as required.

END OF SECTION

01 70 00
PROJECT CLOSEOUT REQUIREMENTS

PART 1 GENERAL**1.1 SUMMARY**

- A. Section includes
 - 1. Field Closeout Procedures for Conditional and Final Acceptance.
 - 2. Project record documents.
- B. Related Sections
 - 1. All Sections of the Standard Construction Specifications.

1.2 SUBMITTALS

- A. Comply with pertinent provisions under section 01 30 00.
- B. District's acceptance of the Project Record Documents will be a prerequisite to District's recommendation for Conditional Acceptance.

1.3 QUALITY ASSURANCE

- A. Delegate the responsibility for maintenance of Record Documents to one person on Owner/Developer or Contractor's staff.
- B. Accuracy of records
 - 1. Thoroughly coordinate changes within Record Documents, making adequate and proper entries on each page of Specifications and each sheet of Drawings and other Documents where such entry is required to show the change properly.
 - 2. Accuracy of records shall be such that future search for items shown in the Construction Documents may rely reasonably on information obtained from accepted Project Record Documents.

1.4 DELIVERY, STORAGE, AND HANDLING

- A. Maintain job set of Record Documents completely protected from deterioration and from loss and damage until completion of the Work and transfer of all recorded data to the final Project Record Documents.
- B. In the event of loss of recorded data, use means necessary to recover the data for District's acceptance to include:
 - 1. Removal and replacement of concealed materials as determined by the District.
 - 2. Perform replacement to the standards originally required by the Construction Documents.

PART 2 PRODUCTS

- A. Job set: Upon approval of Construction Plans the District will make available to Contractor one complete set of all current Standard Construction Specifications and Drawings for access and reference on the work site.
- B. Final Record Documents: The Design Engineer shall be responsible for compiling one complete set of all Construction Documents at the completion of the Work.

PART 3 EXECUTION**3.1 MAINTENANCE OF JOB SET**

- A. Immediately upon receipt of job set, identify each of the Documents with the title, "RECORD DOCUMENTS—JOB SET"
- B. Preservation
 - 1. Provide an acceptable environment for protecting job set, considering the construction completion timeline, the probable number of occasions upon which the job set must be taken out for new entries and/or examination, and the conditions under which these activities will be performed.
 - 2. Do not use job set for any purpose except entry of new data and for review by District, until start of transfer of data to final Project Record Documents.
 - 3. Maintain job set at the site of Work.
- C. Making entries on Drawings
 - 1. Using an erasable colored pencil (not ink or indelible pencil), clearly describe the change by graphic line and note as required.
 - 2. Date all entries.
 - 3. Call attention to the entry by a "cloud" drawn around the area or areas affected.
 - 4. In the event of overlapping changes, use different colors for the overlapping changes.
- D. Make pertinent modifications and entries to the Construction Documents in a timely manner.
- E. Conversion of schematic layouts:
 - 1. The arrangement of conduits, circuits, piping, ducts, and similar items is shown schematically and is not intended for precise physical layout.
 - a. Contractor determines final physical arrangement, subject to District's acceptance.
 - b. The design of future modifications may require accurate information as to the final physical layout of items, shown only schematically on the Drawings.

2. Show on the job set of Record Drawings, by dimension accurate to within one inch, the centerline of each run of items described above.
 - a. Clearly identify the item by accurate note such as "cast iron drain," "galv. water," etc.
 - b. Show, by symbol or note, the vertical location of the item such as "under slab," "in ceiling plenum," "exposed," etc.
 - c. Make all identifications and descriptions such that they may be reliably referenced to the Specifications.
3. The District may waive the requirements for conversion of schematic layouts where, in District's judgment, conversion serves no useful purpose. Any waivers shall be specifically issued in writing by District.

3.2 FINAL PROJECT RECORD DOCUMENTS

- A. The purpose of final Project Record Documents is to provide accurate information regarding all aspects of Work, both concealed and visible, to enable future modification of Work to proceed without lengthy and expensive site measurement, investigation, and examination.
- B. Acceptance of recorded data prior to transfer
 1. Following receipt of copies for Final Record Documents, and prior to start of transfer of recorded data thereto, secure District's acceptance of all recorded data.
 2. Make required revisions.
- C. Transfer of data to Drawings:
 1. Accurately transfer all change data shown on job set of Record Drawings to the corresponding Construction Documents, coordinating the changes as required.
 2. Clearly indicate a full description of changes made during construction, and the actual location of items to be located.
 3. Call attention to each entry by drawing a "cloud" around the area or areas affected.
 4. Make changes neatly, consistently, and with the proper media to ensure longevity and legibility.
- D. Transfer of data to other documents
 1. If Documents other than Drawings have been kept clean during progress of Work, and if entries thereon have been orderly and acceptable to District, the job set of those Documents other than Drawings will be accepted as final Record Documents.
 2. If any Document is not acceptable to the District, obtain a new copy of the document and carefully transfer the changed data to the new copy for review and acceptance by the District.
- E. Review and submittal

1. Submit completed set of Project Record Documents to District as described above and under provisions of Section 01 30 00.
2. Participate in review meetings as required.
3. Make required changes and promptly deliver final Project Record Documents to the District.

3.3 CONDITIONAL ACCEPTANCE

- A. Conditional Acceptance procedures and requirements are summarized in section 5.1.11 of the System Specifications.

3.4 CHANGES SUBSEQUENT TO CONDITIONAL ACCEPTANCE

- A. Contractor has no responsibility for recording changes in Work subsequent to Conditional Acceptance, except for changes resulting from Warranty work.

3.5 FINAL ACCEPTANCE

- A. Final Acceptance procedures and requirements are summarized in section 5.1.12 of the System Specifications.

END OF SECTION

03 00 00
CONCRETE

PART 1 GENERAL**1.1 SUMMARY**

- A. Section Includes
 - 1. Cast in Place Concrete
 - 2. Precast Concrete
 - 3. Reinforcing Steel
 - 4. Forms
 - 5. Concrete accessories

- B. Related Sections
 - 1. All Sections of Division 01.
 - 2. 03 60 00 – Grouting
 - 3. 31 00 00 – Earthwork
 - 4. 33 11 00 – Water Utility Distribution Piping
 - 5. 33 19 00 – Water Utility Structures
 - 6. 33 39 00 – Sanitary Utility Sewerage Structures

1.2 REFERENCES

- A. Reference Standards
 - 1. ACI 214 – Recommended Practice for Evaluating Compression Test Results of Field Concrete
 - 2. ACI 301 – Structural Concrete for Buildings
 - 3. ACI 302 – Recommended Practice for Concrete Floor and Slab Construction
 - 4. ACI 304 – Recommended Practice for Measuring, Mixing, Transporting and Placing Concrete
 - 5. ACI 305/305R – Hot Weather Concreting
 - 6. ACI 306/306R – Cold Weather Concreting
 - 7. ACI 308 – Standard Practice for Curing Concrete
 - 8. ACI 309 – Standard Practice for Consolidation of Concrete
 - 9. ACI 318 – Building Code Requirements for Reinforced Concrete
 - 10. ACI 347 – Recommended Practice for Concrete Formwork
 - 11. ASTM A82 – Cold Drawn Steel Wire for Concrete Reinforcement
 - 12. ASTM A185 – Welded Steel Wire Fabric for Concrete Reinforcement
 - 13. ASTM C31 – Making and Curing Concrete Test Specimens in the Field
 - 14. ASTM C39 – Test Method for Compressive Strength of Cylindrical Concrete Specimens
 - 15. ASTM C143 – Test Method of Slump of Hydraulic Cement Concrete
 - 16. ASTM A615 – Deformed and Plain Billet Steel Bars for Concrete Reinforcement

17. ASTM C33 – Concrete Aggregates
18. ASTM C94 – Ready-Mixed Concrete
19. ASTM C150 – Portland Cement
20. ASTM C171 – Sheet Materials for Curing Concrete
21. ASTM C260 – Air Entraining Admixtures for Concrete
22. ASTM C309 – Liquid Membrane-Forming Compounds for Curing Concrete
23. ASTM C494 – Chemical Admixtures for Concrete
24. ASTM C618 – Fly Ash and Raw or Calcinated Natural Pozzolan for Use as a Mineral Admixture in Portland Cement Concrete
25. ASTM D994 – Preformed Expansion Joint Filler for Concrete (Bituminous Type)
26. ASTM D1190 – Concrete Joint Sealer, Hot-Poured Elastic Type
27. ASTM D1751 – Preformed Expansion Joint Fillers for Concrete Paving and Structural Construction (Non-extruding and Resilient Bituminous Types)
28. ASTM D1752 – Preformed Sponge Rubber and Cork Expansion Joint Fillers for Concrete Paving and Structural Construction
29. ASTM D2103 – Polyethylene Film and Sheeting
30. CRSI – Concrete Reinforcing Steel Institute - Manual of Practice
31. CRSI 63 – Recommended Practice for Placing Reinforcing Bars
32. CRSI 65 – Recommended Practice for Placing Bar Supports, Specifications and Nomenclature
33. PS 1 – Construction and Industrial Plywood

1.3 PERFORMANCE TOLERANCES

- A. Confirm to ACI 301 and ACI 347, as modified herein. In case of conflict, ACI 347 governs over ACI 301.

1.4 ACTION SUBMITTALS

- 1.5** Submit under provisions of Section 01 30 00.

- 1.6** Shop Drawings: Reinforcing bar lists, fabrication and placement drawings

- 1.7** Product Data: Provide sufficient information on mix design and products specified to verify compliance with specifications.

- A. Existing data on proposed design mixes, certified and complete.
- B. Submit reports of field quality control testing.

1.8 QUALITY ASSURANCE

- A. Perform work in accordance with ACI 301.

- B. Acquire cement and aggregate from same source for all work.

1.9 DELIVERY, STORAGE, AND HANDLING

- 1.10** Reinforcing steel: Store on supports which will keep it from contact with the ground and cover.
- 1.11** Rubber and plastic materials: Store in a cool place, do not expose to direct sunlight.
- 1.12** Prepare a delivery ticket for each load of ready-mixed concrete.
- 1.13** Truck operator shall hand ticket to Engineer or Owner's representative at the time of delivery with ticket to show:
 - A. Quantity delivered
 - B. Actual quantity of each material in batch
 - C. Outdoor temp in the shade
 - D. Time at which cement was added
 - E. Numerical sequence of the delivery
 - F. Quantity of water that can be added in the field based on mix design
 - G. Free moisture in fine and coarse aggregate in percent by weight
 - H. Temperature of batch

PART 2 PRODUCTS

2.1 REINFORCING STEEL

- A. Bars: ASTM A615, Grade 60
- B. Welded wire fabric: ASTM A185 or A497
- C. Bar supports: PS 7; CRSI Class B or E, fabricated from galvanized wire having PVC coated legs
- D. Tie Wire: 161/2 gage or heavier, black annealed wire

2.2 CONCRETE

- A. Cement: ASTM C150, Type II

- B. Fly ash: ASTM C618, Class C or Class F, except loss on ignition not more than 5%
- C. Fine aggregate: Clean, natural sand, ASTM C33; no manufactured or artificial sand
- D. Coarse aggregate: Crushed rock, natural gravel, or other inert granular material, ASTM C33 except clay and shale particles no more than 1%
 - 1. Free of all material deleteriously reactive with alkalis in the cement in an amount to cause excessive expansion of concrete
- E. Water: Clean and free from injurious quantity of oils, acids, alkalis, salts, organic materials, or other substances that may be deleterious to concrete or steel. Provide missing water free from deleterious amounts of chloride ion for prestressed concrete or for concrete which will contain aluminum embedments including that portion of the mixing water contributed in the form of free moisture on the aggregates
- F. Admixtures:
 - 1. Air entraining agent: ASTM C260; Grace "Darex AEA", Master Builders "MB-VR", Protex "AES", Sika Chemical "AEK", or equal

2.3 ACCESSORIES

- A. Polyethylene film: ASTM C171, ASTM D2103 6 mil
- B. Expansion Joint Filler: ASTM D1751, asphalt impregnated fiber board sponge, 1/2 inch thickness unless indicated otherwise
- C. Expansion and contraction joint shear bar grease: No-Ox-Id "A Special," axle grease, or equal
- D. Membrane curing compound and floor sealer: ASTM C309, Sonneborn "Sonosil" curing compound or Sonneborn "Lapiolith" concrete hardener and dust proofer, or equal
- E. Bonding Admixture and Bonding Agent: Sika "Sikalatex" bonding admixture and agent or Tamms "Akkro-7T" bonding admixture and Tamms "Tamms Bond" bonding agent, or equal

2.4 MIX

- A. Comply with ASTM C94
- B. Maximum Aggregate Size: 1"
- C. Water/Cementitious Material (Cement and Fly Ash) Ratio:

1. Less than or equal to 0.41
- D. Slump: 4 inch maximum
 1. As low as possible consistent with proper handling and thorough compaction
- E. Volumetric Air Content: $6\% \pm 1\%$ after placement
 1. Maximum $6\% \pm 1\%$ after placement
 2. Vary air content with maximum size aggregate, ASTM C94, table 3
 3. Air may be omitted from interior slabs to be trowel finished
- F. Strength: Compressive strength as determined by ASTM C39: 4000 psi minimum at 28 days
- G. Consistency: Uniform slump, suitable for the placement conditions with aggregate floating uniformly throughout the concrete mass, flowing sluggishly when vibrated or spaded
- H. Adjust mix as required to meet specifications
- I. Contractor may substitute fly ash for up to 22 percent of cement at a ratio of the specific gravity of cement divided by specific gravity of fly ash

PART 3 EXECUTION

3.1 EXAMINATION

- A. Verify site conditions
- B. Verify requirements for concrete cover over reinforcement
- C. Verify that anchors, seats, plates, reinforcement and other items to be encased into concrete are accurately placed, positioned securely, and will not cause hardship in placing concrete

3.2 FORMS

- A. Design to produce hardened concrete to the shape, lines, and dimensions indicated on the drawings
- B. Conform to ACI 347 as modified herein
- C. All Surfaces
 1. Prefabricated plywood panel forms, job-built plywood forms, or forms lined with plywood or fiberboard
 2. Laid out in a regular and uniform pattern with long dimensions vertical and joints aligned

3. Produce finished surfaces free from offsets, ridges, waves, and concave or convex areas
 4. Maximum deviation from a true plane: 1/8 inch within 6 feet
- D. Other type of forms may be used for surfaces not restricted to plywood or lined forms as backing for form lining
 - E. Provide forms above all extended footings; flat segmental forms, 2 foot maximum width, may be used for curved surfaces 25 feet minimum diameter
 - F. When placing concrete against rock, remove all loose pieces of rock and clean exposed surface with high pressure hose
 - G. Provide substantial forms sufficiently tight to prevent leakage of concrete
 - H. Brace or tie forms to maintain desired position, shape, and alignment during and after concrete placement
 - I. Size and space wailers, studs, internal ties and other form supports so proper working stresses are not exceeded
 - J. Where the top of a wall will be exposed to weathering, stop form on at least one side at true line and grade
 - K. Locations to be finished to a specified elevation, slope, or contour, bring form to true line and grade and provide a wooden guide strip at the proper location in the forms for finishing the top surface with a screed or template
 - L. Install form ties on exposed surfaces in uniformly spaced vertical and horizontal rows
 - M. Provide chamfer strips to bevel salient edges and corners. Do not provide for top edges of walls and slabs to be tooled or for edges to be buried
 - N. Do not remove or disturb until concrete has attained sufficient strength to safely support all dead and live loads
 - O. Maintain forms in place for a minimum of 40 hours or for length of curing time in accordance with ACI 306/306R when temperature is 45° F and below
 - P. Remove forms carefully to prevent surface gouging, corner or edge breakage and other damage

3.3 REINFORCING STEEL

- A. Accurately position reinforcing steel on supports, spacers, hangers, or other reinforcing steel

- B. Secure with wire ties or suitable clips. Tie 50 percent of all reinforcement and reinforcement at intersections for wall and floor construction
- C. Where reinforcement is placed in 2 layers, place bars in upper layer directly above bars in lower layer

3.4 EMBEDMENTS

- A. Accurately position and securely anchor in forms, anchor bolts, steel shapes, sleeves, masonry anchorages, and other materials to be embedded in concrete
- B. Anchor bolts
 1. Unless installed in pipe sleeves, provide sufficient threads on anchor bolts to permit a nut on the concrete side of the form or template
 2. Install a second nut on the other side of the form or template
 3. Adjust the nuts to hold the bolt rigidly in the proper position
- C. Clean embedments before installation
- D. Clean concrete spatter and other foreign substances from surfaces not in contact with concrete

3.5 TRANSPORTING MIXED CONCRETE

- A. Transporting of mixed concrete shall conform to ACI 304.
- B. Do not exceed manufacturer's guaranteed capacity of truck agitators. Maintain the mixed concrete in a thoroughly mixed and uniform mass during hauling
- C. Do not incorporate additional mixing water into the concrete during hauling or after arrival at the delivery point, unless ordered by the District. If additional water is to be incorporated into the concrete, revolve the drum not less than 30 revolutions at mixing speed after the water is added and before placing concrete
- D. Furnish a water measuring device in good working condition, mounted on each transit mix truck, for measuring the water added to the mix on the site by the Engineer
- E. Provide delivery ticket and comply with delivery requirements of this section

3.6 PLACING CONCRETE

- A. Place concrete in accordance with ACI 301 and ACI 318
- B. Notify Engineer not less than 24 hrs in advance of the times and places at which contractor intends to place concrete

- C. Do not place concrete older than 90 minutes from batch time to time of placement unless approved by the District.
- D. Predetermine limits at each pour and place all concrete within limits of pour in one continuous operation.
- E. Rigidly secure forms, reinforcing steel, embedment, and anchor bolts in proper position.
- F. Remove all mud, water, ice, snow, frozen material, and debris from space to be occupied by concrete.
- G. Clean surfaces encrusted with dried concrete from previous concrete operations.
- H. Convey to the point of final deposit by methods which will prevent separation or loss of ingredients.
- I. Place concrete in final position without being moved laterally more than 5 feet.
- J. Place concrete in approximately horizontal layers of proper depth for proper compaction, not more than 2 feet.
- K. Place subsequent layer while the preceding layer is still plastic.
- L. Top finish concrete when thoroughly settled.
- M. Remove all laitance, debris, and surplus water from the tops of the forms by screeding, scraping or other effective means.
- N. Overfill the forms for walls whose tops will be exposed to the weather and screed off the excess after the concrete has settled.
- O. Provide vertical construction joints as required to comply with these requirements.

3.7 COMPACTION

- A. Thoroughly compact concrete during and immediately after placement.
- B. Work concrete around all reinforcements and embedments and into the corners of the forms.
- C. Use mechanical vibrators which will maintain 9,000 cycles per minutes when immersed in the concrete, 1 ½ hp motor minimum.

3.8 COLD WEATHER CONCRETING

- A. Conform to ACI 306/306R, except as modified herein.

- B. Minimum concrete temp at the time of mixing.
 - 1. Outdoor Temp at Placement (in shade): Concrete Temp at Mixing
 - a. Below 30° F:70° F
 - b. Between 30° F and 45° F:60° F
 - c. Above 45° F:45° F
- C. Do not place heated concrete which is warmer than 90 degrees F.
- D. If freezing temp are expected during curing, maintain the concrete temp at or above 50 deg F for 5 days or 70 deg F for 3 days with forms in place.
- E. Do not allow concrete to cool suddenly.

3.9 HOT WEATHER CONCRETING

- A. Conform to ACI 305/305R, except as modified herein.
- B. At air temp of 91 degrees F and above keep concrete as cool as possible during placement and curing.
- C. Do not allow concrete temperature to exceed 70 deg F at placement.
- D. Prevent plastic shrinkage cracking due to rapid evaporation of moisture.
- E. Do not place concrete when the actual or anticipated evaporation rate equals or exceeds 0.2 lbs per sq ft per hr as determined from ACI 305, Fig 2.1.4.

3.10 CONSTRUCTION JOINTS

- A. As indicated on the drawings.

3.11 EXPANSION AND CONTRACTION JOINTS

- A. Contraction joints
 - 1. Provide as designated by District.
 - 2. Seal accessible edges.
- B. Expansion material
 - 1. Provide as indicated on drawings.
 - 2. Firmly bond to previously poured joint. Face with a suitable adhesive.
 - 3. Pour new concrete directly against joint filler.
 - 4. Seal accessible edges.

3.12 FINISHING UNFORMED SURFACES

- A. Float finish buried or permanently submerged concrete not forming an integral part of a structure except as required to attain surface elevations, contours, and freedom from laitance.
- B. Screed and initial float finish followed by additional floating, and troweling as required, all other surfaces.
- C. Screeding
 - 1. Screed concrete surfaces to the proper elevation and contours with all aggregates completely embedded in mortar.
 - 2. Surface free of irregularities of height or depth more than 1/4 inch measured from a 10-foot straightedge.
- D. Broom finish
 - 1. Broom finish exterior slabs and exterior concrete stair treads for a non-slip surface.
 - 2. Broom after second floating and at right angles to normal traffic.
- E. Troweling
 - 1. Steel trowel finish interior floor surface which will be exposed at the completion of construction.
 - 2. Trowel to produce a dense, smooth, uniform surface free from blemishes and trowel marks.

3.13 CURING AND PROTECTION

- A. Protect concrete from moisture loss at relatively constant temperature for at least 7 days after placement except that the time for curing by saturation for concrete being protected from low temp shall be 1 day less than the duration of low temp protection.
- B. Cure concrete by methods which will keep concrete surfaces adequately wet during curing, in accordance with ACI 308.
- C. Maintain rate of temperature change less than 5° F in any one (1) hour period.
- D. Water curing
 - 1. Begin water saturation as quickly as possible after initial set.
 - 2. Regulate water application to provide complete surface coverage with a minimum of runoff.
 - 3. Interrupt the application of water to walls for grout cleaning only over the area being cleaned at the time and do not permit the surface to become dry during such an interruption.
- E. Membrane curing

1. Membrane curing compound may be used in lieu of water curing on concrete which will not be covered later with mortar or concrete.
 2. Spray apply membrane curing compound at not more than:
 - a. General use: 300 sf per gal recommended.
 3. Cover unformed surfaces within 30 minutes of final finishing.
 4. If forms are removed before the end of the curing period, immediately apply curing compound to the formed surface before they dry out.
 5. Protect curing compound against abrasion during the curing period.
- F. Film curing
1. Polyethylene sheeting may be used in lieu of water curing on concrete which will be covered or hidden from view.
 2. Begin film curing as quickly after initial set of the concrete as possible.
 3. Completely cover the surfaces with polyethylene sheeting.
 4. Overlap the sheeting edges for sealing and anchorage.
 5. Seal joints between sheets.
 6. Promptly repair tears, holes, and other damage.
 7. Anchor covering continuously at edges and on the surfaces as required to prevent billowing.

3.14 DEFECTIVE CONCRETE

- A. Defective Concrete: Concrete not conforming to required lines, details, dimensions, tolerances, or specified requirements.
- B. Repair or replacement of defective concrete will be determined by the District.
- C. Repair defects in formed concrete surfaces within 24 hours of removing forms.
- D. Replace defective concrete within 48 hrs.
- E. Cut out and remove to sound concrete honeycombed or otherwise defective concrete.
- F. Cut edges square to avoid feathering.
- G. Comply with ACI 301 Section 9.
- H. Perform repair work so as not to interfere with thorough curing of adjacent concrete.
- I. Adequately cure repair work.

3.15 FINISHING FORMED SURFACES

- A. Remove fins and other surface projections from all formed surfaces except exterior surfaces that will be in contact with earth backfill and are not specified to be dampproofed.
- B. Use a power grinder, if necessary, to remove projections and provide a flush surface.
- C. Remove fins and fill tie hole on surfaces exposed to view.
 - 1. Clean, dry and fill tie holes with epoxy grout.
 - 2. Finish flush to match the texture of adjacent concrete.
- D. Grout cleaning under provisions of ACI 301.
 - 1. Grout clean surfaces exposed to view to produce a smooth uniform surface free of marks, voids, surface glaze and cement dust.
 - 2. Use non-shrink grout mix with bonding agent. Dampen surface and apply with cork or rubber float.

3.16 FIELD QUALITY CONTROL

- A. Field test all concrete placed unless directed otherwise by District.
- B. Field testing will be performed in accordance with ACI 301 under provisions of Sections 01 40 00.
- C. All field and compressive strength tests are conducted to determine compliance of concrete materials in accordance with the specifications except as indicated otherwise under provisions of Section 01 40 00.
- D. Field Control Test:
 - 1. Tests by ACI certified technician.
 - 2. Make tests in presence of District.
 - 3. Provide all equipment, supplies, and the services of one or more employees, as required.
 - 4. The test frequencies specified are minimum. Additional tests may be performed as required by the job conditions.
- E. Slump: Test a sample from each truck load in accordance with ASTM C143 if requested by Engineer and when making test cylinders.
- F. Air Content: Test a sample from each truck load if requested by Engineer and when making test cylinders.
- G. Compression Tests:
 - 1. Make one set of 6 cylinders each day when up to 50 cu yards have been placed.
 - 2. Make one additional set of 6 cylinders for each additional 50 cu yds or each major pour placed in one day.

3. Test two cylinders in each set at 7 days. Test one cylinder in each set at 14 days. Test two cylinders in each set at 28 days. The other one cylinder to be used as directed by Engineer at any time.
 4. Engineer will evaluate in accordance with ACI 214 and 318.
 5. Make, cure, store, and deliver cylinders in accordance with ASTM C31.
 6. Test in accordance with ASTM C39.
 7. Mark or tag each set of test cylinders with the date and time of day the cylinders were made, the location in the work where the concrete represented by the cylinders was placed, the delivery truck or batch number, the air content, and the slump.
- H. Storage Facilities for Concrete Test Cylinders
1. Including water necessary, a specially prepared box with high-low thermometer and thermostatically controlled heating devices in accordance with ASTM C31.
- I. Failure of Test Cylinder Results
1. Upon failure of 28-day test cylinder results, the District may require the Contractor to obtain and test at least three 4-inch diameter cored samples from area in question.
 2. Concrete will be considered adequate if average of three core tests is at least 85 percent of, and if no single core is less than 75 percent of, the specified 28-day strength.
 3. In the event an area is found to be structurally unsound, the District may order removal and replacement of concrete as required. The cost of the core tests and removal and replacement of defective concrete shall be borne by the Contractor.
 4. Fill all core holes as specified for repairing defective concrete.

END OF SECTION

**03 60 00
GROUT****PART 1 GENERAL****1.1 SUMMARY**

- A. Section Includes
 - 1. Grouting of column and equipment baseplates.
 - 2. Grouting of anchors and dowels into existing concrete.
 - 3. Grouting of channel inverts in sanitary sewerage manholes.
 - 4. Grouting of manhole step holes.
 - 5. Other grouting specified or indicated on drawings.
- B. Related Sections
 - 1. 03 00 00 – Concrete
 - 2. 33 19 00 – Water Utility Structures
 - 3. 33 39 00 – Sanitary Sewerage Utility Structures

1.2 REFERENCES

- A. Reference Standards
 - 1. ASTM C109 – Test Method for Compressive Strength of Hydraulic Cement Mortar
 - 2. ASTM C157 – Test Method for Length Change of Hardened Hydraulic Cement Mortar and Concrete
 - 3. ASTM C191 – Time of Setting of Hydraulic Cement by Vicat Needle
 - 4. US Corps of Engineers CRD C611 – Test Method for Flow of Grout Mixtures (Flow-Cone Method)
 - 5. US Corps of Engineers CRD C621 – Specification for Non-Shrink Grout

1.3 ACTION SUBMITTALS

- A. Submit under provisions of Section 01 30 00.
- B. Product Data: Provide manufacturer's catalog sheet for material indicating test data and physical properties

1.4 QUALITY ASSURANCE

- A. Conform to applicable industry standard, Corps of Engineers, Specification CRD-C 621—Specification for non-shrink grout

PART 2 PRODUCTS**2.1 NON-SHRINK GROUT**

- A. Manufacturers and Products
 - 1. BASF Corporation—Masterflow 928
 - 2. L & M Inc.—Crystex
 - 3. W.R. Meadows—Sealtight 588
 - 4. Dayton Superior—Sure-Grip High Performance Grout
 - 5. Euclid Chemical—Euco precast grout
 - 6. Sika—SikaGrout 212
 - 7. Or accepted substitution.

- B. Description
 - 1. Non-Metallic, nongas-liberating flowable fluid.
 - 2. Prepackaged natural aggregate grout requiring only the addition of water.

- C. Materials
 - 1. Grout: Factory premixed compound consisting of non-metallic aggregate, cement, water reducing and plasticizing agents, capable of developing minimum compressive strength of 4000 psi in one day and 8000 psi in 7 days.
 - 2. Water: Clean and free from deleterious substances.
 - 3. Bonding Agent: Acrylic liquid compound readily mixable as an admixture to grout.

2.2 ACCESSORIES

- A. Bonding Agents
 - 1. Epoxy Bonding Agent
 - a. BASF Corporation---Masterflow 648
 - b. Sika—SikaGrout 328
 - c. Or approved equal
 - 2. Latex Bonding Agent: Acrylic liquid compound readily mixable as an admixture to grout
 - a. Specco—B20 Liquid Latex
 - b. Euclid Chemical—Flex-Con
 - c. MR Meadows—Intralok Bonding Agent
 - d. Or approved equal

PART 3 EXECUTION

3.1 NON-SHRINK GROUT

- A. Preparation
 - 1. Clean concrete surface to receive grout.
 - 2. Saturate concrete with water for 24 hours prior to grouting and remove excess water just prior to placing grout.
 - 3. Cold weather conditions:

- a. Warm concrete, substrate, and base plate to 40 °F, or above; store grout in warm area.
- b. Follow manufacturer's recommendations for cold weather application.
4. Hot weather conditions:
 - a. Use cold mixing water and cool base plate if possible.
 - b. Store grout in cool area.
 - c. Follow manufacturer's recommendations for hot weather application.
5. Apply to clean, sound surface.
6. Apply latex bonding agent to hardened concrete, mix-in-grout, or as directed by Engineer.

B. Application

1. Mix in a mechanical mixer.
2. Use no more water than necessary to produce appropriate placement constancy required for the work.
3. Provide expansion joints on long pours.
4. Provide air vents where necessary to eliminate air pockets.
5. Place in accordance with manufacturer's instructions.
6. Completely fill all spaces and cavities below the top of baseplates.
7. Provide forms where baseplates and bedplates do not confine grout.
8. Where exposed to view finish grout edges smooth.
9. Except where a slope is indicated on the drawings, finish edges flush at the baseplate, bedplate, member or piece of equipment.
10. Protect against rapid moisture loss by immediately covering with wet rags and polyethylene sheets or curing compound.
11. Wet cure grout for 7 days, minimum.
12. Maintain the temperature at a minimum of 40 °F until grout reaches 3000 psi.
13. After placement of grout, eliminate excessive external vibration.

END OF SECTION

07 11 13
BITUMINOUS DAMPROOFING

PART 1 GENERAL**1.1 SUMMARY**

- A. Section Includes
 - 1. Bituminous type damproofing of precast concrete manholes, vaults, meter pits, and cast-in-place exterior foundation walls.
- B. Related Sections
 - 1. 03 00 00 – Concrete
 - 2. 33 39 00 – Sanitary Utility Sewerage Structures
 - 3. 33 19 00 - Water Utility Structures

1.2 REFERENCES

- A. Referenced Standards
 - 1. ASTM D 1187 – Standard Specification for Asphalt-Base Emulsions for Use as Protective Coatings for Metal
 - 2. ASTM E 96 – Standard Test Method for Water Vapor Transmission of Materials

1.3 ACTION SUBMITTALS

- A. Submit under provisions of Section 01 30 00.
- B. Product Data: Provide data, certificates, and material safety data sheets on damproofing product. Label submittal with type and intended use.
- C. Manufacturer's Instructions: Indicate special surface preparation procedure, substitute conditions requiring special attention.

1.4 DELIVERY, STORAGE, AND HANDLING

- A. Store Materials in an enclosed space protected from weather and direct sunlight.
- B. Maintain a temperature range of 40° F to 90° in the storage area.

1.5 SITE CONDITIONS

- A. Ambient Conditions: Do not apply at ambient temperatures below 40° F, nor during inclement weather.
- B. Substrate: Cured for a minimum of 7 days.

PART 2 PRODUCTS**2.1 SEMI-MASTIC DAMPROOFING**

- A. Manufacturers
 - 1. BASF Building Systems
 - 2. W.R. Meadows, Inc.
 - 3. Euclid Chemical
 - 4. Or accepted substitution.
- B. Description
 - 1. Type: ASTM D 1187, water based, fibered, consisting of refined asphalt, emulsifiers, and clay fillers.
 - 2. Source: Hydrocide 700B by BASF, Sealmastic Emulsion by W.R. Meadows, Inc., or Dehydratine 75 by Euclid Chemical.
 - 3. Water vapor permeance: Maximum 1.0 grams/100 square inches/24 hours, tested to ASTM E 96.

2.2 ACCESSORIES

- A. Mastic: ASTM D 1187, fibrated, consisting of refined asphalt, non-asbestos fibers, emulsifiers, and clay fillers; trowel grade.
- B. Reinforcing Fabric: Woven glass fiber type.
- C. Patching Compound: The type recommended by the dampproofing manufacturer.

PART 3 EXECUTION**3.1 EXAMINATION**

- A. Verify that surface substrate conditions are ready to receive work as instructed by the product manufacturer.
- B. Examine surfaces scheduled to be finished prior to commencement of work. Report any condition that may potentially affect proper application.
- C. Test shop applied primer for compatibility with subsequent cover materials.
- D. Do not proceed with surface preparation or coating application until conditions are suitable.

3.2 PREPARATION

- A. Surface preparation per manufacturer's instructions and as approved by Engineer.
- B. Apply dampproofing and coal tar epoxy to clean, dry surfaces:

1. Remove dirt, dust, sand, grit, mud, oil, grease, and other foreign matter.
 2. Protect surfaces not to be coated from contamination, discoloration or other damage with drop cloths or other suitable methods.
- C. Do not add any adulterants or unauthorized thinners.
- D. Thoroughly mix each time paint withdrawn from container.
- E. Keep containers closed tightly except while paint is withdrawn.
- F. Thinning only permitted to obtain recommended coverage at lower application temperatures.

3.3 APPLICATION

- A. General
1. Apply products in accordance with manufacturer's instructions.
 2. Do not apply initial coating until moisture content of surface is within moisture limitations of coating manufacturer.
 3. Apply paint with suitable brushes, rollers, or spraying equipment:
 - a. Rate of application shall not exceed that as recommended by paint manufacturer for the surface involved.
 - b. Keep brushes, rollers, and spraying equipment clean, dry, free from contaminants and suitable for the finish required.
 4. Comply with recommendation of product manufacturer for drying time between succeeding coats.
 5. Finish coats shall be smooth, free of brush marks, streaks, laps or pile up of paint, and skipped or missed areas.
 6. Make edges of coating adjoining other materials or colors clean and sharp with no overlapping.
 7. Do not permit coating to get on top of concrete walls or on exposed wall surfaces above specified limits.
 8. Do not use Benzol or other volatile toxic solvents for thinning coating.
 9. Provide adequate forced ventilation when applying coating in enclosed spaces to:
 - a. Remove all vapors from solvents as rapidly as produced.
 - b. Ensure that workers are adequately protected.
 10. Inspection
 - a. Do not apply additional coats until completed coat has been inspected by the Engineer.
 - b. Only inspected coats of paint will be considered in determining number of coats applied.
- B. Damproofing
1. Apply in two coats with high pile rollers, brush or air spray equipment recommended by manufacturer.

2. Application Rate: 15-18 square feet per gallon (1/8 inch total thickness).
 - a. Application rate may vary with manufacturer.
 3. Apply only when surface of concrete is clean, dry and when temperatures are 40 degrees F and rising.
 4. Apply in a continuous, unbroken film, free of pinholes.
 5. Do not apply when temperatures less than 35 degrees F are anticipated.
 6. Do not apply in rain or when rain is threatening.
 7. Backfill in accordance with manufacturer's instructions.
- C. Coal Tar Epoxy Damproofing
1. Apply in two coats with brush.
 2. Apply when temperatures are 45 degrees F and rising.
 3. Total dry film thickness: 20 mils.

3.4 SCHEDULE

- A. Semi-Mastic Dampproofing
1. Shop-coat all exterior wall surfaces of precast vault and manholes in contact with earth or backfill below finished grade. Include exterior surfaces of sump.

END OF SECTION

**SECTION 31 00 00
EARTHWORK**

PART 1 GENERAL

1.1 SUMMARY

- A. Section Includes
 1. Clearing, grubbing and site preparation
 2. Removal and disposal of debris and excess materials
 3. Handling, storage, transportation, and disposal of excavated material
 4. Rough grading
 5. Trench excavation
 6. Sheeting, shoring, bracing and protection work
 7. Pumping and dewatering as required or necessary
 8. Subgrade preparation
 9. Backfilling
 10. Pipe embedment
 11. Final grading
 12. Appurtenant work

- B. Related Sections
 1. Section 03 30 00 – Concrete
 2. Section 33 11 00 – Water Utility Distribution Piping
 3. Section 33 12 00 – Water Utility Distribution Equipment
 4. Section 33 13 00 – Water Utility Structures
 5. Section 33 31 00 – Sanitary Utility Sewerage Piping
 6. Section 33 39 00 – Sanitary Utility Sewerage Structures

1.2 REFERENCES

- A. Reference Standards
 1. ASTM C33 – Concrete Aggregates
 2. ASTM C136 – Sieve Analysis of Fine and Coarse Aggregates
 3. ASTM D1241 – Material for Soil Aggregate Sub-base, Base and Surface Courses
 4. ASTM D698 – Test Methods for Moisture-Density Relations of Soils and Soil Aggregate Mixtures Using 5.5 lb Rammer and 12-Inch Drop
 5. ASTM D1557 – Test Methods for Moisture Density Relations of Soils and Soil Aggregate Mixtures Using 10-lb Rammer and 18 inch drop
 6. ASTM D4253 – Test Methods for Maximum Index Density of Soils Using a Vibratory Table
 7. ASTM D4254 – Test Methods for Minimum Index Density of Soils and Calculations of Relative Density
 8. ASTM D6938 – Standard Test Method for In-Place Density and Water Content of Soil and Soil-Aggregate by Nuclear Methods (Shallow Depth)

1.3 ACTION SUBMITTALS

- A. Submit under provisions of Section 01 30 00.
- B. Product Data: Submit on all products or materials supplied herein.
- C. Test and Evaluation Reports
 - 1. Indicate sieve analysis, optimum moisture content and density in accordance with ASTM D698 for cohesive soils including onsite native material.
 - 2. Indicate supplier, sieve analysis, and maximum relative density in accordance with ASTM D4253 and D4254 for crushed rock or gravel, pipe embedment and other cohesionless material for fills and embankment.

1.4 RECORD DOCUMENTATION

- A. Submit under provisions of Section 01 70 00 and related Sections.
- B. Submit Compaction Testing Reports for all public sanitary sewerage or water utility installations.
- C. Note any use of trench stabilization or dewatering activities on the Record As-Builts.

1.5 REGULATORY REQUIREMENTS

- A. Where burning is allowed, comply with all codes, regulations and laws, and obtain all necessary permits relative to burning, fire prevention and air pollution.
- B. Comply with all requirements of State, El Paso County Erosion Control Permit, and State Construction Dewatering Permit.

1.6 QUALITY ASSURANCE

- A. Protect adjacent structures and surrounding areas from damage during excavation, filling, and backfilling.
- B. Protect work from erosion or other similar types of damage until the project has been completed.
- C. Do not backfill or construct fills during freezing weather. Backfill or construct fills only when temperature is 35°F and rising.
- D. Do not use frozen materials, snow, or ice in any backfill or fill area.
- E. Do not backfill or construct fill on frozen surfaces.

- F. Protect excavated material from becoming frozen.
- G. Do not remove trees from outside excavation or fill areas unless authorized by the District; protect from permanent damage by construction activities.
- H. Provide temporary bridges for roadways, walkways, driveways, etc.

PART 2 PRODUCTS

2.1 TRENCH STABILIZATION MATERIAL

- A. Graded Gravel: 1-1/2-inch minus:

Sieve Size (Inch)	Percent Passing by Weight
2	100
1-1/2	95-100
1	80-95
3/4	30-45
1/2	10-25
3/8	<1

- B. Cobble: 4" to 6"
- C. Or accepted substitution.

2.2 PIPE EMBEDMENT

- A. Graded Gravel
 - 1. Washed 3/4-inch minus:

Sieve Size (Inch)	Percent Passing by Weight
1	100
3/4	95-100
1/2	25-45
3/8	<5

- 2. Washed pea gravel: 3/8-inch
- 3. Squeegee:

Sieve Size (Inch)	Percent Passing by Weight
3/8	100
No. 4	85-100
No. 8	30-70
No. 16	5-40
No. 30	0-15
No. 50	0-10
No. 100	0-5
No. 200	<1

A. Or accepted substitution.

2.3 COMPACTED TRENCH BACKFILL (ABOVE PIPE EMBEDMENT ZONE):

A. Job excavated material finely divided, free of debris, organic material, and stones larger than 3 inch in greatest dimension without masses of moist, stiff clay unless shown otherwise on plans.

B. Graded gravel: As specified for pipe embedment.

2.4 TRENCH COVER

A. Free of brush, debris, and roots.

B. May contain rubble and detritus from rock excavation, stones and boulders if well separated and arranged not to interfere with backfill settlement.

C. In upper 18 inches: no rock or rock excavated detritus except with specific approval of District.

D. No stones larger than 8 inch in greatest dimension within 3 feet of top of pipe.

2.5 COMPACTED STRUCTURAL BACKFILL

A. Earth only, free of wood, grass, roots, broken concrete, stones, trash, or debris of any kind.

B. Moisture content uniformly distributed and such that maximum density of compacted soil will be obtained.

2.6 DITCH CHECKS:

- A. Per State and El Paso County Erosion control requirements.

2.7 COARSE AGGREGATE

- A. Graded gravel in conformance with El Paso County Department of Transportation specifications. D50 = 3.

PART 3 EXECUTION**3.1 EXAMINATION**

- A. Field verify the location of all underground utilities, pipelines and structures prior to excavation.

3.2 PERFORMANCE

- A. Perform work in a safe and proper manner with appropriate precautions against hazard.
- B. Provide adequate working space and clearances for work performed within excavations and for installation and removal of concrete forms.
- C. Do not undercut excavation faces for extended footings.
- D. Clean subgrades of loose material before concrete is placed thereon.
- E. Except as otherwise authorized, indicated, or specified, replace all material excavated below the bottom of concrete walls, footings, slabs on grade and foundations with concrete placed at the same time and monolithic with the concrete above.
- F. Except where exterior surfaces are to be dampproofed, concrete structures that do not have footings that extend beyond the outside face of exterior walls may be placed directly against excavation faces without outer forms.

3.3 PREPARATION

- A. Clear sites to be occupied by permanent construction of roots, brush, and other objectionable material and debris.
- B. Clean and strip subgrade for fills and embankments of surface vegetation, sod, tree stumps and organic topsoil.
- C. Remove waste materials from site and dispose.

- D. Preparation of right of ways - clean, as necessary, for access, stringing of pipeline materials and construction of pipelines and appurtenant structures.
- E. Remove debris, all trees, underbrush, stumps, roots and other combustible materials from site daily and dispose of off-site; on-site burning is not permitted.
- F. Do not use open burning.

3.4 PRESERVATION OF TREES

- A. Do not remove trees outside fill or excavated areas, except as authorized by District or shown on the plans.
- B. Protect trees left standing from permanent damage by construction operation.
- C. Trim standing trees as directed by District.

3.5 TOPSOIL

- A. Remove and stockpile sufficient topsoil to surface to a minimum depth of 4 inches fill, embankment, and other areas where the original topsoil will be covered or damaged.
- B. Import additional clean material to surface fill embankments, berms, and other areas where original topsoil will be covered or damaged.
- C. At the completion of other work in each area, place and grade topsoil to maintain gradient as indicated.

3.6 DEWATERING

- A. Provide and maintain adequate dewatering equipment to remove and dispose of surface and groundwater entering excavations, trenches, and other parts of the work.
- B. Keep each excavation dry during subgrade preparation and continually thereafter until the structure to be built or the pipe to be installed is completed to the extent that no damage from hydrostatic pressure, flotation, or other cause will result.
- C. Dewater excavations which extend to or below groundwater by lowering and keeping the groundwater level beneath such excavation at least 12 inches below the bottom of the excavation.
- D. Divert surface water or otherwise prevent it from entering excavated areas or trenches to the extent practical without damaging adjacent property.

- E. Maintain all drainage pipes, keep clean and free of sediment during construction and final cleanup.
- F. Obtain and comply with conditions of CDPHE construction dewatering permit.

3.7 SHEETING, SHORING AND BRACING

- A. Provide proper and substantial sheeting, shoring, and bracing, as required, to prevent caving or sliding, to protect workmen and the Work, and to protect existing structures and facilities.
- B. Design and build sheeting, shoring, and bracing to withstand all loads that might be caused by earth movement or pressure, and to be rigid, maintaining shape and position under all circumstances.
- C. Do not pull trench sheeting before backfilling unless pipe strength is sufficient, to carry trench loads based on trench width to the back of sheeting.
- D. Do not brace sheeting left in place against the pipe, but support it in a manner that precludes concentrated loads or horizontal thrusts on pipe.
- E. Cross braces installed above the pipe to support sheeting may be removed after pipe embedment is completed.

3.8 TRENCH STABILIZATION

- A. Perform trench stabilization at direction of District. In general, if groundwater is encountered in the embedment zone, over-excavation and trench stabilization will be required.
- B. Thoroughly compact and consolidate subgrades for concrete structures, precast structures, and utility trench bottoms so they remain firm, dense and intact during required construction activities.
- C. Remove all mud and muck during excavation.
- D. Reinforce subgrades with crushed rock or gravel if they become mucky during construction activities.
- E. Finished elevations of stabilized subgrades are to be at or below subgrade elevations indicated on drawings.
- F. Allow no more than 2 inch depth of mud or muck to remain on trench bottoms when pipe bedding material is placed thereon.

3.9 CRUSHED ROCK OR GRAVEL FILLS

- A. Place on suitably prepared subgrade and compacted.
- B. Compacted by vibration.

3.10 EXCAVATION WITHIN EXISTING ROADWAYS AND SUBGRADE PREPARATION

- A. Excavate in roadways, drives and parking area per the lines, grades cross sections and dimensions indicated on drawings.
- B. Excavate unsuitable material from the subgrade.
- C. After shaping, roll subgrade and compact a minimum of 6" depth of subgrade to 95 percent of maximum density within 2 percent (+/-) optimum moisture content, ASTM D698 or to the density required by the entity having jurisdiction within roadway.
- D. Reshape and wet as required.
- E. Remove soft or otherwise unsuitable material, and replace with suitable material.

3.11 BLASTING

- A. No blasting allowed unless specifically authorized by the District.

3.12 TRENCH EXCAVATION

- A. Establish alignment and grade or elevation from offset stakes.
- B. Excavate trenches so pipes can be laid straight at uniform grade without dips or bumps, between the terminal elevations indicated on the drawings.
- C. Comply with pipe specification sections regarding vertical and horizontal alignment and maximum joint deflection.
- D. Where grades or elevations are not fixed on the drawings, excavate trenches to provide a minimum depth of backfill cover over the top of pipe.
 - 1. 6'-0" for water piping
 - 2. 4'-0" for sewer piping
 - 3. Increase depth as required at vertical curves and for clearance beneath existing pipes, conduits, drains, drainage structures, or other obstructions encountered at normal pipe grades.
- E. Measure pipe cover depth vertically from top of pipe to finished ground or surface elevation.

- F. Do not open more trench in advance of pipe laying than is necessary to expedite the work; never more than 400 feet.
- G. Except where tunneling or other installation method is indicated on the drawings, specified, or permitted by District, excavate trenches by open cut from the surface.
- H. Limiting trench widths:
 - 1. Excavate to a width which will provide adequate working space and pipe clearances for proper pipe installation, jointing, embedment.
 - 2. If needed to reduce earth loads to prevent sliding, cut banks back on slopes which extend not lower than 1 foot above the top of the pipe.
 - 3. Stipulated minimum clearances are minimum clear distances, not minimum average distances
 - 4. Maximum trench width from 6 inches above the top of pipe to the trench bottom of the in-stalled pipe: Pipe O.D. plus 24 inches
 - 5. Limiting trench widths and permissible clearances from 6 inches above top of pipe to trench bottom for installed pressure and non-pressure piping:

Pipe Size (inch)	Minimum Trench Width	Maximum Trench Width
6	1'-6"	2'-6"
8	1'-8"	2'-8"
10	1'-10"	2'-10"
12	2'-0"	3'-0"
14	2'-2"	3'-2"

- I. Mechanical excavation
 - 1. Do not use where its operation would damage buildings, culverts, or other existing property, structures, or utilities above or below ground; hand excavate only in such areas.
 - 2. Use mechanical equipment of a type, design, and construction and operated so that:
 - a. Rough trench bottom elevation can be controlled
 - b. Uniform trench widths and vertical sidewalls are obtained from 1 foot above the top of the installed pipe to the bottom of the trench
 - c. Trench alignment is such that pipe is accurately laid to specified alignment and is centered in the trench with adequate clearance between pipe and trench sidewalls
 - 3. Do not undercut trench sidewalls.

4. Recompact trench bottom disturbed by bucket teeth prior to placement of embedment material.
- J. Except as otherwise required, excavate trenches below the underside of pipes as indicated in the drawings to provide for installation of granular embedment pipe foundation material.
- K. Whenever so directed by District, excavate to such depth below a grade as District directs and bring the trench bottom to grade with such material as District may direct.
- L. Provide trench stabilization material made necessary by unstable soil as directed by District.
- M. Excavate to provide adequate clearance for tools and methods of pipe installation.
- N. Do not allow any of bells or couplings to contact the trench bottom, walls, or granular embedment when pipe is joined.
- O. Cuts in surface construction
 1. No larger than necessary to provide adequate working space.
 2. Cut a clean groove not less than 12 inch deep along each side of trench or around perimeter of excavation area.
 3. Remove pavement and base pavement to provide shoulder not less than 6 feet wide between cut edge and top edge of trench.
 4. Do not undercut trenches, resulting in bottom trench width greater than top widths.
 5. Make pavement cuts to and between straight or accurately marked curved lines parallel to trench centerline or limits of excavation.
 6. Remove pavement for connections to existing lines or structures only to the extent required for the installation, as determined by District.
 7. Where the trench parallels the length of a concrete walk that is all or partially over the trench, remove and replace the entire walk.
 8. Where the trench crosses the drives, walks, curbs, or other surface construction, remove and replace the surface construction between saw cuts as specified for pavement.

3.13 PIPE EMBEDMENT

- A. Embed pipes above and below the bottom of pipe as indicated in the drawings and as specified.
 1. 6-inch minimum compacted thickness below pipe.
 2. 12-inch minimum compacted thickness above pipe.
- B. Spread and surface grade granular embedment to provide continuous and uniform support beneath pipe at all points between pipe joints.

- C. After grading, aligning, and placing pipe in final position, and shoring home, deposit and compact sufficient embedment under and around each side of the pipe and to hold the pipe in proper position and alignment during subsequent operations.
- D. Place and compact embedment material uniformly and simultaneously on both sides of pipe to prevent lateral displacement.
- E. Granular embedment
 1. Compact by slicing with shovel or vibrating
 2. Maximum uncompacted thickness of layers: 6 inches
 3. Compact to 95 percent maximum density as determined by ASTM D698 or compact to 70 percent relative density ASTM D4253/D4254 as applicable

3.14 TRENCH BACKFILL

- A. Compacted backfill.
 1. For full depth of trench above embedment.
 2. Beneath pavements, surfacing, driveways, curbs, gutters, walks or other surface construction or structures.
 3. In street or highway shoulders.
 4. In established sodded areas.
 5. Beneath fills and embankments.
- B. Where the trench for one pipe passes beneath the trench of another pipe, compact the backfill for the lower trench to the bottom of the upper trench.
- C. Place job excavated materials in 8 inches maximum uncompacted thickness, uniform layers.
- D. Increased layer thickness may be permitted for uncohesive material if Contractor demonstrates to District's satisfaction that specified compacted density will be achieved.
- E. Use methods and equipment appropriate to the material to be compacted to prevent transmission of damaging shocks to pipe.
- F. Compact to 95 percent of maximum density within 2 percent (+/-) optimum moisture content per ASTM D1557 when under driven surfaces within El Paso County Department of Transportation Rights of Way, compact to 95 percent of maximum density within 2 percent (+/-) optimum moisture content per ASTM D698 in all other areas or to an equivalent percent relative density per ASTM D4253/D4254 when appropriate.
- G. Graded gravel

1. Deposit in uniform layers of 12 inches maximum uncompacted thickness.
2. Compact with suitable vibrating roller or platform vibrator to not less than 70 percent relative density per ASTM D4253/D4254.

3.15 FILLS AND EMBANKMENTS OVER STRUCTURES

- A. Use methods which will not overload or damage the structure.
- B. Use vehicles with rubber tires to the extent possible.
- C. Do not use equipment with a loaded weight greater than 14,000 pounds.
- D. Operate equipment to prevent impact loads on structure.
- E. Distribute equipment loads with planks or a layer of earth or gravel 12 inch minimum, 18 inch maximum, thick.
- F. Do not pile earth or gravel more than 3 feet deep.
- G. Take special care to prevent damaging or disturbing roofing membrane, the drains, or granular fill material.

3.16 DRAINAGE MAINTENANCE

- A. Do not backfill trenches across roadways, drives, walks or other trafficways adjacent to drainage ditches or water courses prior to backfilling the trench on the upstream side of the trafficway to prevent impounding water after pipe is laid.
- B. Backfill so that water does not accumulate in unfilled or partially filled trenches.
- C. Remove materials deposited in roadway ditches or other water courses crossed by the trench line immediately after backfilling is completed and restore ditches and water courses to original section, grade, and contours.
- D. Do not obstruct surface drainage any longer than necessary.
- E. Provide and maintain temporary bridges and other structures across unfilled trenches as required to maintain traffic.

3.17 PROTECTION OF TRENCH BACKFILL

- A. Where trenches are constructed in ditches or other water courses, protect backfill from erosion.
- B. Install ditch checks where the ditch grade exceeds 1 percent.
 1. Minimum depth: 2 feet below the original ditch or water course bottom for the full bottom width

2. Minimum width: 18 inches into the side slopes
3. Minimum thickness: 12 inches

3.18 FINAL GRADING

- A. After completion of all other outside work and after backfilling is completed and settled, bring to grade at the indicated elevations all areas of the site to be graded.
- B. Graders and other power equipment may be used for final grading and slope dressing if the result is uniform and equivalent to hand work.
- C. Grade all surfaces for effective drainage.
- D. Provide a 2 percent minimum slope except as otherwise required.
- E. Grade and surface to maintain gradient as indicated.

3.19 FIELD QUALITY CONTROL

- A. Provide under provisions of Section 01 40 00.
- B. Coordinate all tests to determine compliance of in-place and backfill materials and compaction in accordance with the specifications.
- C. Pipe Embedment and Backfill
 1. Under Driven surfaces contained within the El Paso County Department of Transportation Right of Way:
 - a. Two initial gradation tests for each type of material plus 1 additional test for 500 cubic yards of each material.
 - b. Two moisture-density relationship tests, ASTM D1557, or 2 relative density tests, ASTM D4253/D4254, as appropriate for each type of embedment or backfill material proposed, except granular embedment material.
 - c. One in-place compaction test every 100 lineal feet of trench in the compacted embedment zone and at every 12 inches of vertical lift of backfill materials, ASTM D6938.
 - d. Five (5) additional in-place compaction tests at the discretion of the District, ASTM D6938.
 2. All other locations:
 - a. Two initial gradation tests for each type of material plus 1 additional test for 500 cubic yards of each material.
 - b. Two moisture-density relationship tests, ASTM D698, or 2 relative density tests, ASTM D4253/D4254, as appropriate for each type of embedment on backfill material proposed, except granular embedment material.

- c. One in-place compaction test every 100 lineal feet of trench in the compacted embedment zone and at every 12 inches of vertical lift of backfill materials.
- d. Five (5) additional in-place compaction tests at the discretion of the District, ASTM D6938.

END OF SECTION

33 11 00
WATER UTILITY DISTRIBUTION PIPING

PART 1 GENERAL**1.1 SUMMARY**

- A. Section Includes
 - 1. Pipe for site water lines

- B. Related Sections
 - 1. 31 00 00 – Earthwork
 - 2. 33 12 00 – Water Utility Distribution Equipment
 - 3. 33 13 00 – Disinfection of Water Utility Distribution Piping
 - 4. 33 19 00 – Water Utility Structures

1.2 REFERENCES

- A. Reference Standards
 - 1. ASME B16.18 – Cast Copper Alloy Solder Joint Pressure Fittings
 - 2. ASME B16.22 – Wrought Copper and Copper Alloy Solder Joint Pressure Fittings
 - 3. ANSI B31.9 – Building Service Piping
 - 4. ASTM D2466 – Poly (Vinyl Chloride) (PVC) Plastic Pipe Fittings, Schedule 40
 - 5. AWS A5.8 – Brazing Filler Metal
 - 6. AWWA C104 – Cement-Mortar Lining for Ductile-Iron Pipe and Fittings for Water
 - 7. AWWA C105 – Polyethylene Encasement for Ductile Iron Piping for Water and Other liquids
 - 8. AWWA C110 – Ductile Iron & Grey Iron Fittings, 3” through 48”, for Water and Other Liquids
 - 9. AWWA C111 – Rubber-Gasket Joints for Ductile Iron and Grey-Iron Pressure Pipe and Fittings
 - 10. AWWA C150 – Thickness Design of Ductile-Iron Pipe
 - 11. AWWA C151 – Ductile-Iron Pipe, Centrifugally Cast in Metal Molds or Sand-Lined Molds, for Water or Other Liquids
 - 12. AWWA C600 – Installation of Ductile-Iron Water Mains and Appurtenances
 - 13. AWWA C605 - Underground Installation of Polyvinyl Chloride (PVC) Pressure Pipe and Fittings for Water
 - 14. AWWA C606 – Grooved and Shouldered Type Joints
 - 15. AWWA C900 – Polyvinyl Chloride (PVC) Pressure Pipe and Fabricated Fittings, 4 In. Through 12 In. (100mm through 300mm), for Water Transmission and Distribution

16. AWWA C909-09 Molecularly Oriented Poly Vinyl Chloride (PVCO) Pressure Pipe, 4 In. Through 24 In. for Water, Wastewater, and Reclaimed Water Service
17. ASTM B88 – Seamless Copper Water Tube
18. ASTM D1784 - Standard Specification for Rigid Poly Vinyl Chloride (PVC) Compounds and Chlorinated Poly Vinyl Chloride (CPVC) Compounds
19. ASTM D1785 – Poly (Vinyl Chloride) (PVC) Plastic Pipe, Schedules 40, 80, and 120
20. ASTM D2241 – Poly (Vinyl Chloride) (PVC) Plastic Pipe (SDR-PR)
21. ASTM D2855 – Making Solvent-Cemented Joints with Poly (Vinyl Chloride) (PVC) Pipe and Fittings
22. ASTM D3139 – Joints for Plastic Pressure Pipes using Flexible Elastomeric Seals
23. ASTM D3035 – Polyethylene (PE) Plastic Pipe (SDR-PR) Based on Controlled Outside Diameter
24. ASTM F477 - Standard Specification for Elastomeric Seals (Gaskets) for Joining Plastic Pipe
25. NSF 61 – Drinking Water System Components-Health Effects
26. PPI TR-4 – Plastic Pipe Institute Listed Materials for Thermoplastic Piping Materials or Pipe

1.3 ACTION SUBMITTALS

- A. Submit Under the provisions of Section 01 30 00.
- B. Shop Drawings: Provide piping layout fabrication and assembly drawings with fitting dimensions for piping installed inside of a structure. Provide sufficient information to verify compliance with specifications.
- C. Product Data: Provide data on pipe materials and accessories. Provide manufacturer's catalog information with dimensions, material, and assembled weight. Indicate pressure ratings for pipe.
- D. Manufacturer's Certificate: Certify that products meet or exceed specified requirements.
- E. Test Reports: Submit reports of field pressure tests under provisions of Section 01 40 00.

1.4 PROJECT RECORD DOCUMENTS

- A. Submit under the provisions of Section 01 70 00.
- B. Accurately record actual locations of piping mains, valves, connections, and top of pipe elevations.

1.5 QUALITY ASSURANCE

- A. Perform Work in accordance with all applicable codes and regulations.
- B. Manufacturer's name and pressure rating marked on all piping.

1.6 REGULATORY REQUIREMENTS

- A. Conform to all municipal codes and ordinances, laws and regulations of the state.
- B. In case of apparent conflict, state and local requirements govern over these specifications.
- C. In absence of state and local regulations, International Plumbing Code applies.

1.7 DELIVERY, STORAGE, AND HANDLING

- A. Deliver, store, protect and handle products to site under provisions of Section 01 60 00.
- B. Provide temporary end caps and closures on piping and fittings. Maintain in place until installation.
- C. During loading, transporting, and unloading, exercise care to prevent damage to material:
 - 1. Use slings, hooks, pipe tongs, or skids.
 - 2. Do not drop pipe or fittings.
 - 3. Do not roll or skid against pipe already on ground.
 - 4. Repair any damage done to coating or lining.
 - 5. Handle per manufacturer's recommendations.
 - 6. Store rubber gaskets in cool dark location.
 - 7. Store all material on wood pallets or timbers.
- D. Adequately tag or otherwise mark all piping as to size.

PART 2 PRODUCTS**2.1 DUCTILE IRON PIPE**

- A. Manufacturers
 - 1. Griffin Pipe Products Company
 - 2. U.S. Pipe
 - 3. Tyler Pipe & Coupling
 - 4. Clow
 - 5. Or accepted substitution.
- B. General

- a. AWWA C150 and AWWA C151: As listed below except as otherwise specified or indicated on Drawings.
 - 1) Underground Installation: Push-on joints and mechanical joints with joint restraint device or restrained joints: Pressure Class 350 (4" through 12") and Pressure Class 250 (14" through 30").
 - 2) Above Ground Installation and where specifically noted on plans: flanged or grooved joints: Pressure Class 350 (4" through 12") and Pressure Class 250 (14" through 30").
 - b. Maximum pipe laying lengths is 20 feet.
- C. Fittings:
1. Ductile Iron: ANSI A21.10/AWWA C110, ASTM A536, Grade 80-60-03 or 70-50-05, 350 psi pressure rating for fittings 12" and smaller, 250 psi pressure rating larger than 12".
 2. Ductile Iron Compact Fittings: ANSI A21010/AWWA C153, 350 psi pressure rating for fittings 12" and smaller, 250 psi pressure rating larger than 12".
 3. High Deflection Couplings – Not Allowed
- D. Linings
1. Composite Epoxy and Polyethylene Lining:
 - a. Primer coating containing fusion bonded epoxy.
 - 1) Minimum Thickness: 5 mils.
 - b. Surface Coating containing fusion bonded polyethylene.
 - 1) ANSI/ASTM D 1248.
 - c. American Polybond Plus.
 - d. Application:
 - 1) Apply in accordance with the manufacturer's recommendations.
 - 2) Interior pipe surface to be free from mud, oil, grease, and other foreign contaminants prior to application of lining.
 - 3) Abrasive blast the interior pipe surface using sand or grit abrasive media prior to application of lining.
 - 4) Only slight stains and tightly adhered oxide may be left on the interior pipe surface.
 - 5) Heat pipe in accordance with the manufacturer's recommendations.
 - 6) Minimum thickness: 50 mils DFT.
 - 7) Line joint surface in accordance with the manufacturer's recommendations.
 - 8) Unless otherwise specified on the construction documents, all ductile iron pipe linings shall be cement mortar lining in accordance with AWWA C104. Additional specialized

linings are listed above and may be specifically called for on the approved plans.

2. Ceramic Epoxy:
 - a. Amine Cured Novalac Epoxy.
 - b. Protecto 401.
 - c. Application:
 - 1) Apply in accordance with the manufacturer's recommendations.
 - 2) Interior pipe surface to be free from mud, oil, grease, and other foreign contaminants prior to application of lining.
 - 3) Abrasive blast interior pipe surface using sand or grit abrasive media prior to application of lining.
 - 4) Only slight stains and tightly adhered oxide may be left on the interior pipe surface.
 - 5) Minimum thickness: 40 mils DFT.
 - 6) Minimum Pipe and ambient air temperature: 40°F.
 - 7) Line joint surface in accordance with the manufacturer's recommendations.
- E. Exterior Coating:
 1. One mil thick bituminous coating of either coal-tar or asphalt base. The finished coating shall be continuous, smooth, neither brittle when cold nor sticky when exposed to the sun and shall be strongly adherent to the pipe.
 2. Piping within vaults: Shop applied primer compatible with the coating system specified herein.
- F. Joint Design and Fabrication:
 1. Standard joint shall be a single rubber gasket joint designed to be assembled by the positioning of a continuous, molded rubber ring gasket in an annular recess in the pipe or fitting socket and the forcing of the plain end of the entering pipe into the socket, thereby compressing the gasket radially to the pipe to form a positive seal.
- G. Grooved couplings:
 1. Standard groove/rigid groove.
 2. Pipe ends less than or equal to 24 inches: Grooved with "radius groove".
- H. Mechanical joints: ANSI A21.11/AWWA C111
- I. Flanged joints:
 1. Flanges, General use: ANSI A21.15 and ANSI B16.1, 125 lb
- J. Polyethylene encasement: AWWA C105: seamless tube, ASTM D1248, Type I, Class C, Grade E-1, 8 mils thick:

1. Joint tape: Self-sticking, PVC or polyethylene, 2-inch wide, 10 mils thick, Chase "Cahsekote 750," Kendall "Polyken 900," 3M "Scotchrap 50," or equal
2. Strapping: Nonmetallic, water resistant, FS PPP-S-760, Type II
3. Harness rods shall be covered by 4-inch flat width polyethylene tubing. The entire joint shall be covered by a complete wrap of 48-inch wide polyethylene sheet material cover over each set of lugs.

2.2 POLYVINYL CHLORIDE (PVC) PIPE

- A. Manufacturers:
 1. JM Eagle
 2. Vinyltech
 3. North American Specialty Products
 4. Or accepted substitution.
- B. Description (Mains):
 1. Type: AWWA C900 (DR14) or C909 PVC DR 14
 2. Maximum pipe laying lengths is 20 feet.
 3. Color:
 - a. Domestic Water: Blue
 - b. Raw Water: Purple, or purple stripe
- C. Fittings:
 1. Ductile Iron: ANSI A21.10/AWWA C110, ASTM A536, Grade 80-60-03 or 70-50-05, 350 psi pressure rating for fittings 12" and smaller, 250 psi pressure rating larger than 12".
 2. Ductile Iron Compact Fittings: ANSI A21010/AWWA C153, 350 psi pressure rating for fittings 12" and smaller, 250 psi pressure rating larger than 12".
 3. High Deflection Couplings: AWWA C900/C909, 200 psi working pressure rating, North American Specialty Products – "Fluid-Tite PVC Stop & Repair Coupling".
- D. Pipe Compound: ASTM D1784
- E. Gaskets: Compression Gasket Ring, ASTM F477
- F. Joints: ASTM D3139
- G. Deflection:
 1. Maximum length of pipe that can be used without exceeding the allowable pipe deflection specified by the manufacturer shall be determined.
 2. Maximum radius of curvature shall be as recommended by the pipe manufacturer or as specified by District, whichever is greater.
 3. Joint deflection is **not allowed**.

- H. For 2-1/2” Service Lines: Iron Pipe Sized (IPS) PVC pipe, gasketed bell and spigot, ASTM D2241, SDR 21 with 200 psi working pressure rating, JM Eagle “IPS Pressure” pipe or equal. Ductile Iron gasketed push on fittings (i.e. PVC ends), IPS size, ASTM A536, AWWA C153, 250 psi pressure rated, Harrington Corporation or equal. All fittings and valves must be restrained using ductile iron fitting restraints, Harrington Corporation Ductile Iron IPS restraints or equal.

2.3 COPPER TUBING

- A. Water tubing: Buried, ASTM B88; FS WW-T-799, Type K soft (annealed); or FS WW-T-775
- B. Water tubing: Exposed or above grade, ASTM B88; Type L, hard drawn
- C. Flanges: Cast bronze, 150 psig, brazed joints, ANSI B16.24:
 - 1. Flange bolts and nuts: As specified for steel pipe
 - 2. Flange gaskets: As specified for steel pipe, except full face
 - 3. 1/16-inch-thick preformed neoprene gaskets

2.4 HDPE TUBING

- A. Water tubing: Buried, PE 4710 ASTM D2239, AWWA C901, NSF/ANSI 61, SDR-9 minimum, 200 psi minimum, copper tubing size (CTS); coil;
 - 1. Sizing: HDPE service lines shall be upsized one nominal pipe size from Type K Copper tubing such that the inner diameter (ID) is no less than Type K Copper ID. The HDPE tap equivalent shall be 1” for a 3/4” tap, 1.5” for 1” tap, and 2” for 1.5” tap. Type K Copper shall be used for 2” and 2.5” taps.

HDPE 4710 CTS vs Type K CTS

<i>Size (in)</i>	<i>Min Wall Thickness (in)</i>		<i>OD (in)</i>		<i>ID (in)</i>	
	<i>HDPE</i>	<i>Type K</i>	<i>HDPE</i>	<i>Type K</i>	<i>HDPE</i>	<i>Type K</i>
3/4”	-	0.065	-	0.875	-	0.745
1”	0.125	0.065	1.125	1.125	0.875	0.995
1.5”	0.181	0.072	1.625	1.625	1.263	1.481
2”	0.236	0.083	2.125	2.125	1.653	1.959

- 2. Color: Blue
- 3. Markings:
 - a. Nominal pipe size and diameter base (CTS)
 - b. Dimension ratio
 - c. Material designation code/resin type (PE 4710)
 - d. AWWA pressure class
 - e. Manufacturer name and testing agency seal
- 4. Manufacturers:

- a. Polytech Pipe Products Municipal BLUE ULTRA PE4710 CTS SDR 9
 - b. JM Eagle Pure-Core SDR 9 CTS
 - c. Or approved equal
- B. Fittings and Appurtenances: HDPE service lines must have stainless steel stiffening inserts of sufficient restraint length at all points of connection.
- C. For exterior buried applications only. Approved transition coupling to copper pipe must be installed inside the building 6" to 12" above the floor of the foundation entrance, and 1" to 1-1/2" Unistrut must be anchored to the floor as meter assembly support. Copper pipe shall be used from the transition coupling until 5 feet after the outlet valve of the backflow prevention assembly. For outdoor meter pits, the water service line must be copper.
- D. HDPE service pipe must have washed pea gravel or squeegee bedding (Reference Section 31 00 00) 3" below and 6" above, and tracer wire from saddle to foundation (Reference Detail G-6).

2.5 TRACER WIRE

- A. Manufacturers and Products
1. Material: # 10 AWG copper clad steel, high strength with minimum 600 lb. break load.
 2. Coating: Minimum 30 mil HDPE insulation thickness for direct bury.
 3. Color: Blue
 4. Connectors: Moisture displacement and corrosion resistant connectors.
 - i. Copperhead Snakebite
 - ii. 3M DBR
 - iii. Or approved substitution
- B. Terminal Stations
1. Copperhead 2" two-terminal switchable lid, model SP-SWLID-*2 or approved substitution
 2. Color: Blue
 3. Text: WATER
 4. Installed at minimum every 500 feet along pipeline, and at all fire hydrants and water valves.
- C. Grounding
1. Magnesium anode, 1.5 pounds minimum, securely grounded and connected to terminal lid

2.6 ACCESSORIES

- A. Pipeline Marker Tape
1. Width: 6 inches minimum

2. Thickness: 5 mil minimum
3. Color: Blue
4. Backing: Aluminum
5. Printing: "Caution Buried Water Line Below"

PART 3 EXECUTION

3.1 EXAMINATION

- A. Verify that building service connection and municipal utility water main size, location and invert are as indicated.
- B. Carefully examine pipe and fittings for cracks, damage to linings, and other defects prior to installation.
- C. Remove all defective pipe from site and replace.
- D. Examine areas for weak or structural defects or deviations beyond allowable tolerances for piping clearances that adversely affect excavation and quality of Work.
- E. Start installation only when conditions are satisfactory.

3.2 PREPARATION

- A. Ream pipe and tube ends and remove burrs.
- B. Remove scale and dirt, on inside and outside, before assembly.
- C. Prepare pipe connections to equipment with flanges or unions.

3.3 EXCAVATION

- A. Excavate pipe trench in accordance with Section 31 00 00.

3.4 INSTALLATION

- A. Install as specified or in accordance with the manufacturer's recommendations.
- B. Cutting Pipe:
 1. Cut pipe to measurement taken at the site, not from the drawings.
 2. Cut pipe neatly without damage to pipe, lining, and coating.
 3. Cut smooth, straight, and at right angles to pipe axis.
 4. Dress and bevel end of cut pipe to remove roughness and sharp corners, recoat exposed metal with epoxy coating for potable water.
 5. Cut ductile iron pipe with saw or abrasive wheel.
 6. For push-on joint connections, the cut end shall be beveled.

- C. Maintain ten feet of horizontal separation of water main from sewer piping, measured from center line to center line.
- D. Route pipe according to the lines and grades noted on construction documents.
- E. Install pipe to allow for expansion and contraction without stressing pipe or joints.
- F. Install access fittings as needed to permit disinfection of water system performed under Section 33 13 00.
- G. Protect from lateral displacement by placing embedment evenly on both sides of pipe.
- H. Do not lay pipe in water. Do not lay pipe under unsuitable weather or trench conditions.
- I. Lay pipe with bell ends facing the direction of laying except when District authorizes reverse laying.
- J. Establish elevations of buried piping to ensure not less than 6 feet of cover and not more than 8 feet of cover measured from finished grade to top of pipe.
- K. Install tracer wire continuous over top of all water main lines and service lines.
- L. Backfill trench for main and service lines in accordance with Section 31 00 00.
- M. Install marker tape continuous at top of pipe bedding.
- N. Protect piping systems from entry of foreign materials by temporary covers.

3.5 JOINTING

- A. Connect pipe joints carefully and neatly.
- B. Connect piping in accordance with manufacturer's recommendations.
- C. Push-On:
 - 1. The inside of the bell and the outside of the spigot end shall be thoroughly cleaned to remove oil, grit, excess coating, and other foreign matter.
 - 2. Rubber gasket shall be flexed inward and inserted in the gasket recess of the bell socket. In cold weather it may be necessary to warm the gasket in order to facilitate insertion.
 - 3. A thin film of non-toxic, water-soluble gasket lubricant shall be applied to either the inside surface of the gasket, the spigot end of the pipe, or both.
 - 4. Spigot end of the pipe shall be entered into the socket with care used to keep the joint from contacting the ground. The joint shall then be

completed by forcing the plain end to the bottom of the socket in a manner approved by the District.

5. Each joint shall be checked with a feeler gauge to ensure proper installation of the gasket.
6. Pipe that is not furnished with a depth mark shall be marked before assembly to ensure that the spigot end is inserted to the proper depth of the joint, per Manufacturer specifications.
7. Field cut pipe joints shall be filed or ground to resemble a spigot end as recommended by the manufacturer.
8. Field-cut end repairs are to be done in accordance with the pipe manufacturer's recommendations.
9. Deflection of the joint shall not exceed the manufacturer's recommended maximum deflection.

D. Threaded:

1. ANSI B2.1, NPT fully and cleanly cut with sharp dies.
2. No more than 3 threads exposed after installation.
3. Ream pipe ends after threading to remove burrs.
4. Apply thread tape to joints in all plastic and stainless steel piping.
5. Apply thread tape or joint compound to joints in other piping.
6. Apply Teflon thread tape or litharge and glycerin paste to joints in steel piping for chlorine service.

E. Compression:

1. Cut pipe ends squarely, remove burrs.
2. Clean contact surfaces with steel wool.

F. Soldered and brazed:

1. Braze joints in 2 inch or larger copper tubing.
2. Solder or braze lines smaller than 2 inch where solder fittings are specified.
3. Thoroughly clean joint surfaces with flint paper and coat with thin film of flux.
4. Install tubing to full depth of socket.
5. Do not overheat metal or flux.
6. Uniformly heat joint to melt filler metal on contact.
7. Remove surplus filler metal and flux while joint is still hot.

G. Mechanical Joints:

1. If an effective seal is not obtained, disassemble joint, clean thoroughly, and reassemble.
2. Do not over-tighten gland joint bolts to compensate for poor installation.
3. Carefully align holes in mechanical joints with restraint device to permit installation of the harness bolts.

4. Install flange and mechanical joint pieces so the four mechanical joint holes, as well as the flange holes, straddle the top centerline for horizontal piping, or the side centerline for vertical piping.
- H. Flanged joints:
1. Take care when bolting flanges to ensure that there is no restraint on the opposite end of the pipe which would prevent gasket compression or cause unnecessary stress in flanges.
 2. Leave one flange free to move in any direction while tightening flange bolts.
 3. Do not pack or assemble bell and spigot joints until all flanges affected thereby have been tightened.
 4. Tighten bolts gradually at a uniform rate to compress gaskets uniformly.
- I. Grooved couplings:
1. Cut grooves with grooving tool.
 2. Groove to rigid grooving dimensions.
 3. Groove cleanly and sharply without burrs or check marks.
 4. Form rounded bottom "radius grooves" in plastic piping.

3.6 CONNECTION TO EXISTING PIPELINES

- A. Make connections between new and existing piping with suitable fittings.
- B. Schedule connection to minimize inconvenience to the customers of the District and as authorized by the District.
- C. Provide facilities for adequate dewatering and disposal of water from dewatered line and excavations without damage to adjacent property.
- D. Potable water lines:
1. Take special care to prevent contamination.
 2. Do not permit trench water, mud, or other contaminating substances in lines.
 3. Thoroughly clean the interior of pipe and fittings and swab with, or dip into, a 200 mg/L chlorine solution.

3.7 POLYTHEYLENE ENCASEMENT MATERIAL

- A. General
1. Polyethylene encasement material used to protect buried ductile iron pipe and fittings, valves, valve supports and other items as specified, shall meet the requirements of AWWA C105. Material may be either 8 mil linear low density polyethylene film (LLDPE), or 4 mil high density cross laminated polyethylene film (HDCLPE).
 2. Polyethylene material shall be stored out of direct sunlight.

- B. Installation
1. All material to be protected shall be cleaned prior to wrapping operations.
 2. During installation, soil or embedment material shall not be trapped between the polyethylene material and the item to be protected.
 3. Polyethylene encasement shall be secured at ends, seams, overlaps and folds by adhesive tape or plastic tie straps approved for such purpose.
 4. Sufficient slack shall be provided in contouring the encasement around buried items to prevent stretching the material where it bridges irregularities and to prevent damage by backfilling operations.
 5. Cuts, tears, punctures and other damage to the polyethylene material shall be repaired with adhesive tape and a short length of additional polyethylene material, if needed. The District shall inspect all repairs prior to all backfilling activities.
- C. Field Pipe Wrapping
1. A precut length of tubing approximately 20 feet long shall be used per 18-foot length of pipe. Before lowering into the trench, tubing shall be slid over the bell end of the pipe and bunched behind the bell.
 2. In the trench, the bell end of the pipe shall be raised clear of the trench bottom, and the tubing stretched out along the length of pipe. One foot surplus shall be provided at each end of a length of pipe. This surplus shall be bunched behind each end of the length of pipe.
 3. After each joint is made, tubing shall be pulled over the bell end of the pipe, folded around the adjacent spigot end, and wrapped circumferentially with pressure-sensitive tape.
 4. Excess polyethylene material shall be drawn up around the pipe barrel, folded neatly into an overlap on top of the pipe, and held in place by pressure-sensitive tape at 3 to 5 feet intervals.
 5. The following flat width tubing shall be used if required:
 - a. Nominal Pipe Diameter / Flat Tubing Width
 - 1) 6 inches / 20 inches
 - 2) 8 inches / 24 inches
 - 3) 12 inches / 30 inches

3.8 FIELD QUALITY CONTROL

- A. Field inspection and testing will be performed under provisions of Section 01 40 00.
- B. Test each line in the presence and to the satisfaction of the District.
- C. Provide all necessary pumping equipment, piping connections, pressure gauges, and other required equipment, facilities, and materials.
- D. If tests indicate Work does not meet specified requirements, remove, replace, repair, and retest.

- E. Hydrostatic Test Conditions
 1. At lowest point in the line or section being tested.
 2. All poured in place concrete used for water mains will be allowed to cure for a minimum of 7 days prior to hydrostatic testing.
 3. Notify the District 48 hours minimum prior to testing.
 4. District will provide water for initial and filling of test pipeline.
 5. Flush and disinfect the portion of system to be tested per Section 33 13 00.

- F. Hydrostatic Test Procedure:
 1. Disconnect all fixture devices and other accessories which may be damaged by the specified test pressure.
 2. Plug or cap ends as required.
 3. Fill section to be tested using a fire hydrant, isolation valve, or other method acceptable to the District.
 4. Bleed air from the system using a fire hydrant, blow-off valve, or other method acceptable to the District.
 5. Once system is filled and air bled, completely isolate portion of system to be tested from all existing lines.
 6. Increase pressure in system as needed to reach 200 psi minimum.
 7. Record start pressure and time as witnessed by the District.
 8. Test for 2 hours minimum with less no drop in pressure.
 9. Record end pressure and time as witnessed by the District.

- G. All joints shall be tight:
 1. Repair leaking joints.
 2. Repeat tests on repaired lines.

- H. Immediately replace all pipe fittings, valves, pipe joints, and other materials found to be defective with new and acceptable material.

3.9 SCHEDULE

- A. Copper tubing for all domestic service lines 2 inches and smaller.
- B. Polyvinyl chloride or Ductile Iron Pipe for all domestic and fire service lines 2-1/2" inches and greater.
- C. Polyvinyl chloride pipe for all public distribution mains, except as specified on the Construction Documents.
- D. Ductile Iron Pipe for all fire hydrant laterals.

END OF SECTION

33 12 00
WATER UTILITY DISTRIBUTION EQUIPMENT

PART 1 GENERAL**1.1 SUMMARY****A. Section Includes**

1. Valves, hydrants, blow-off assemblies, joint restraints, tapping saddles and accessories.

B. Related Sections

1. 03 30 00 – Concrete
2. 31 00 00 – Earthwork
3. 33 11 00 – Water Utility Distribution Piping
4. 33 13 00 – Disinfection of Water Utility Distribution
5. 33 19 00 – Water Utility Structures

1.2 REFERENCES**A. Referenced Standards**

1. ASME B16.18-Cast Copper Alloy Solder Joint Pressure Fittings
2. ASME B16.22-Wrought Copper and Copper Alloy Solder Joint Pressure Fittings
3. ANSI B31.9-Building Service Piping
4. ASTM D2466-Polyvinyl Chloride (PVC) Plastic Pipe Fittings, Schedule 40
5. AWS A5.8-Brazing Filler Metal
6. AWWA C105-Polyethylene Encasement for Ductile Iron Piping for Water and Other liquids
7. AWWA C110-Ductile-Iron and Gray-Iron Fittings, 3 Inch through 48 Inch, for Water and Other Liquids
8. AWWA C111-Rubber-Gasket Joints for Ductile Iron and Grey-Iron Pressure Pipe and Fittings
9. AWWA C153-Ductile-Iron Compact Fittings, 3 Inch through 12 Inch, for Water and Other Liquids
10. AWWA C500-Gate Valves, 3 through 48 in NPS, for Water and Sewage Systems
11. AWWA C502-Dry Barrel Fire Hydrants
12. AWWA C504-Rubber Seated Butterfly Valves
13. AWWA C508-Swing-Check Valves for Waterworks Service, 2 in through 24 in NPS
14. AWWA C509-Resilient Seated Gate Valves 3 in through 12 in NPS, for Water and Sewage Systems
15. AWWA C515-Reduced-Wall, Resilient-Seated Gate Valves for Water Supply Service

16. AWWA C550-Protective Interior Coatings for Valves and Hydrants
17. AWWA C606-Grooved and Shouldered Type Joints
18. AWWA C901-Polyethylene (PE) Pressure Pipe, Tubing, and Fittings, 1/2 inch through 3 inch, for Water
19. ASTM D2855-Making Solvent-Cemented Joints with Poly Vinyl Chloride (PVC) Pipe and Fittings
20. ASTM D3139-Joints for Plastic Pressure Pipes using Flexible Elastomeric Seals
21. NSF 61-Drinking Water System Components-Health Effects
22. UL 246-Hydrants for Fire-Protection Service

1.3 ACTION SUBMITTALS

- A. Submit under provisions of 01 30 00.
- B. Shop Drawings: Provide piping layout fabrication and assembly drawings with fitting dimensions for water utility distribution piping located within a structure. Provide sufficient information to verify compliance with specifications.
- C. Product Data: Provide data on pipe fittings, valves, and accessories. Provide manufacturer's catalog information with dimensions, material, and assembled weight. Indicate pressure ratings for all fittings.
- D. Manufacturer's Certificate: Certify that products meet or exceed specified requirements.
- E. Test Reports: Submit reports of field pressure tests under the provisions of Section 01 40 00 and according to the hydrostatic testing specifications in Section 33 11 00.

1.4 PROJECT RECORD DOCUMENTS

- A. Submit under the provisions of Section 01 70 00.
- B. Accurately record actual locations of piping mains, valves, connections, and top of pipe elevations.

1.5 QUALITY ASSURANCE

- A. Perform Work in accordance with all applicable codes and regulations.
- B. Manufacturer's name and pressure rating marked on piping, valves, and hydrants.

1.6 REGULATORY REQUIREMENTS

- A. Conform to all municipal codes and ordinances, laws and regulations of the State.

- B. In case of apparent conflict, state and local requirements govern over these specifications.
- C. In absence of state and local regulations, International Plumbing Code applies.

1.7 DELIVERY, STORAGE, AND HANDLING

- A. Deliver, store, protect and handle products to site under provisions of Section 01 60 00.
- B. Deliver and store valves and accessories in shipping containers with labeling in place in accordance with AWWA C509/515.
- C. Provide temporary end caps and closures on all fittings. Maintain in place until installation.
- D. Seal valve ends to prevent entry of foreign materials into valve body
- E. During loading, transporting, and unloading, exercise care to prevent damage to material.
 - 1. Use slings, hooks, pipe tongs, or skids.
 - 2. Do not drop pipe or fittings.
 - 3. Do not roll or skid against pipe already on ground.
 - 4. Repair any damage done to coating or lining.
 - 5. Handle per manufacturer's recommendations.
 - 6. Store rubber gaskets in cool dark location.
 - 7. Store all material on wood pallets or timbers.
- F. Adequately tag or otherwise mark all piping and fittings as to size.

PART 2 PRODUCTS

2.1 GATE VALVES (2" THROUGH 12")

- A. Manufacturers:
 - 1. American AVK - series 45 or 65.
 - 2. American Flow Control – Series 2500
 - 3. Or accepted substitution.
- B. AWWA C515 or C509, minimum working pressure of 250 psi., ductile iron body, lead-free, stainless steel stem, minimum of two O-ring stem seals, non-rising stem with square nut, single wedge fully encapsulated with EPDM rubber, resilient seat, mechanical joint ends, control rod, and extension box.
- C. Rotation: Open left (counterclockwise) with the word "OPEN" and an arrow indicating the direction to open cast on valve body.

2.2 VALVE BOXES (2-1/2" AND LARGER VALVES)**A. Manufacturer and Product**

1. Tyler Union 6855 Series # 6 Base

B. Description

1. Threaded type.
2. Cast iron box, base, extensions, and lid.
3. Minimum inside diameter 5 inches.
4. Minimum wall thickness 3/16 inch.
5. All parts coated by dipping in asphalt varnish.
6. Minimum lid depth 3".
7. Lid is drop type and marked with "WATER".

2.3 BALL VALVES**A. Manufacturers**

1. Nibco - T-595-CS-R-66-LL
2. Velan V3P-1000
3. Or accepted substitution.

B. Description

1. For use on 2 inch and smaller non buried piping.
2. Three-piece, carbon steel body, threaded ends, full port with blowout proof stem.
3. 316 SS trim w/vented ball, certified to NSF 61.
4. 300 lbs minimum working pressure rating.

2.4 AIR AND VACUUM RELIEF VALVES**A. Manufacturers**

1. Vent-O-Mat – Series RBX
2. Or accepted substitution.

B. Description

1. For use on 3 inch thru 12 inch site water lines.
2. Combination, integral type, air release and vacuum relief valve.
3. 300 psi minimum working pressure rating.

- C. Size noted on plans to be confirmed by valve manufacturer. The District will provide min and max flow rates.

2.5 FIRE HYDRANTS**A. Manufacturers and Products**

1. American AVK (C502 only) Series 2700 Modern Style, or
2. Kennedy Guardian K81
3. Color: Red

- B. AWWA C502, UL 246, open left, dry barrel type, inside dimension of 7 inches minimum, with 5 inches diameter valve seat opening; minimum net water area of barrel not less than 190 percent of valve opening; 6 inch mechanical joint inlet connection with accessories, gland bolts and gaskets.
- C. Hydrant Extensions: Use pre-manufactured and compatible products.
- D. Fire Hydrant Lateral Pipelines shall be Ductile Iron Pipe.

2.6 FLUSHING HYDRANTS

- A. Manufacturers and Products
 - 1. Kupferle Foundry Company – “Truflo” model TF500
 - 2. Or accepted substitution
- B. ANSI/NSF 372, open left, dry barrel type, 2” diameter, FIP inlet, MIP outlet.

2.7 MECHANICAL JOINT RESTRAINT

- A. Manufacturers and Products
 - 1. EBAA Iron MEGALUG Series 1100 (for DIP pipe)
 - 2. EBAA Iron MEGALUG Series 2000 PV (for PVC pipe)
 - 3. Or accepted substitution
- B. Description
 - 1. Multiple wedging action type.
 - 2. Twist off nuts used to ensure proper actuating of the restraining device.
 - 3. Working pressure rated to at least 250 psi.

2.8 BELL RESTRAINT

- A. Manufacturers and Products
 - 1. EBAA Iron MEGALUG Series 1700 (for DIP pipe)
 - 2. EBAA Iron MEGALUG Series 1900 (for PVC pipe)
 - 3. Or accepted substitution
- B. Description
 - 1. Multiple wedging action type.
 - 2. Twist off nuts used to ensure proper actuating of the restraining device.
 - 3. Working pressure rated to at least 250 psi.

2.9 RESTRAINED FLANGED COUPLING ADAPTER

- A. Manufacturers and Products
 - 1. Romac Industries Style RFCA
 - 2. Or accepted substitution
- B. Description
 - 1. Twist off nuts used to ensure proper actuating of the restraining device

2. Working pressure rated to at least 250 psi

2.10 TAPPING SADDLES

A. Manufacturers and Products

1. Romac Stainless Steel Repair Clamp with Tapping Saddle.
2. PowerSeal Model 3450AS Stainless Steel SaddleCorp.
3. Or accepted substitution.

B. Description

1. Stainless Steel.
2. Minimum dual 304 stainless steel straps, washers, and nuts.
3. Rubber seating gasket.
4. 250 psi minimum pressure rating.

C. No direct taps.

2.10 CORPORATION STOPS

A. Manufacturer and Products

1. Ford ball corporation valve, Model FB600-X- XX, AWWA taper inlet X Flare, Ford quick joint compression or pack outlet, 300 psi. working pressure.
2. Mueller 300 ball corporation valve, AWWA taper X Flare, Mueller 110 compression or pack outlet, 300 psi. working pressure
3. Or accepted substitution.

2.11 CURB STOPS

A. Manufacturers and Products

1. Ford "B" Series Ball Curb Valve (Non Minneapolis style), Flare inlet X Flare, ford quick joint compression or pack outlet 300 psi. working pressure
2. Mueller 300 Ball Curb Valve (Non Minneapolis style), Flare inlet X flare, Mueller 110 compression or pack outlet, 300 psi. working pressure
3. Or accepted substitution.

2.12 CURB STOP BOXES (2" AND SMALLER CURB VALVES)

A. Manufacturers and Products

1. Tyler Union 6500 series, ¾" through 1 ½" curb valves: Arched style base, cast iron sections, slip or screw type extensions, with asphalt bituminous coating, 27/32" standard lid with pentagon head plug. For curb stop valves 2" in size, use "enlarged" box base.
2. McDonald Manufacturing Co Arch Pattern with brass cotter pin and pentagon bolt lid with tracer wire terminal, ¾" to 1" curb valves: Model 5607. For 1 ½" to 2" curb valves: Model 5606.
3. Or accepted substitution.

2.13 TRACER WIRE

A. Manufacturers and Products

1. Material: # 10 AWG copper clad steel, high strength with minimum 600 lb. break load.
 2. Coating: Minimum 30 mil HDPE insulation thickness for direct bury.
 3. Color: Blue
 4. Connectors: Moisture displacement and corrosion resistant connectors.
 - i. Copperhead Snakebite
 - ii. 3M DBR
 - iii. Or approved substitution
- B. Terminal Stations
1. Copperhead 2” two-terminal switchable lid, model SP-SWLID-*2 or approved substitution
 2. Color: Blue
 3. Text: WATER
 4. Installed at minimum every 500 feet along pipeline, and at all fire hydrants and water valves.
- C. Grounding
1. Magnesium anode, 1.5 pounds minimum, securely grounded and connected to terminal lid

2.14 ACCESSORIES

- A. Cast in place concrete for thrust blocks: As specified in Section 03 30 00.
- B. Pre-Cast concrete blocks:
1. Manufacturer: Firebaugh Precast or accepted substitution
 2. Dimensions: per plan/per detail
 3. Thickness: per plan/per detail
 4. Specification for pre-cast sections: ASTM C478
 5. Reinforcement: Welded wire fabric, ASTM A185
- C. Pipeline Marker Tape
1. Width: 6 inches minimum
 2. Thickness: 5 mil minimum
 3. Color: Blue
 4. Backing: Aluminum
 5. Printing: “Caution Buried Water Line Below”
- D. Vent Piping 4 inch and larger: ASTM A36 Schedule 40 steel pipe with shop applied coating.
1. Coating:
 - a. Primer: One coat rust inhibitive zinc-rich shop primer – 3 mils Tnemec “Hydrozinc 2000” or approved equal
 - b. Finish: One coat coal tar epoxy – 18 mils Tnemec “series 46-465” or approved equal
 - c. Total dry film thickness – 20 mils
 2. Vent Screen: Stainless steel with 3/32” mesh
- E. Vent/Blow Off Assy. Piping 3 inch and smaller: Schedule 40 brass pipe.

1. Dielectric nipples: Zinc electroplated steel casing with inert plastic lining. Precision Plumbing Products "Clearflow" or approved equal.

F. Corrosion Control

1. Shop paint all ferrous metal surfaces of valves and accessories, both interior and exterior, for corrosion protection
2. Manufacturer's standard paint will be acceptable if it is functionally equivalent and compatible with specified field coatings
3. Exterior bituminous coating or asphalt varnish: Manufacturer's Standard
4. Shop lining: Cement, AWWA C104/C205 or Epoxy coating for potable water, AWWA C210
5. Rust inhibitive primer: Tnemec "Series 77 Chem-Prime," Sherwin Williams "Ken Kromick Universal Metal Primer," or approved equal
6. Rust preventative compound: Houghton "Rust Veto 344," Rust-Oleum "R-9," or equal
7. Polyethylene encasement: AWWA C105: seamless tube, ASTM D1248, Type I, Class C, Grade E-1, 8 mils thick:
 - a. Joint tape: Self-sticking, PVC or polyethylene, 2-inch wide, 10 mils thick, Chase "Cahsekote 750," Kendall "Polyken 900," 3M "Scotchrap 50," or equal.
 - b. Strapping: Nonmetallic, water resistant, FS PPP-S-760, Type II.
 - c. Harness rods shall be covered by 4-inch flat width polyethylene tubing. The entire joint shall be covered by a complete wrap of 48-inch wide polyethylene sheet material cover over each set of lugs.

PART 3 EXECUTION

3.1 EXAMINATION

- A. Verify that building service connection and municipal utility water main size, location and invert are as indicated.
- B. Carefully examine pipe and fittings for cracks, damage to linings, and other defects prior to installation.
- C. Remove all defective pipe from site and replace.
- D. Examine areas for weak or structural defects or deviations beyond allowable tolerances for piping clearances that adversely affect excavation and quality of Work.
- E. Start installation only when conditions are satisfactory.

3.2 PREPARATION

- A. Ream pipe and tube ends and remove burrs.
- B. Remove scale and dirt, on inside and outside, before assembly.
- C. Thoroughly inspect and clean interior of fire hydrants. Open and close hydrant to ensure

parts are in working order, the valves seat properly and the drain valve operates.

- D. Check packing gland and gland nut of fire hydrant for proper installation.
- E. Check oil level or grease fittings, if applicable.

3.3 EXCAVATION

- A. Excavate pipe trench in accordance with Section 31 00 00.

3.4 INSTALLATION

- A. Install valves, hydrants, and accessories in accordance with the manufacturer's recommendations.
- B. Set all valves, fire hydrants, and solid sleeves on a solid bearing surface consisting of 1-1/2" gravel which extends down to the subgrade preparation surface, laterally to the sidewalls of the excavation trench, and up to the top of adjacent trench bedding.
- C. Center and plumb valve box over valve. Set box or concrete vault cover flush with finished grade. Evenly fill around box concrete vault and thoroughly compact on all sides.
- D. Install precast concrete block beneath curb stop. Install 1-1/2" plastic pipe insert, minimum 5 feet in length, into curb stop valve cans, centered on curb stop valve. Any curb stops deeper than 6 feet will require curb stop extension.
- E. Set hydrants plumb and locate pumper nozzle perpendicular to roadway unless otherwise directed by District or shown on the construction plans.
- F. Pipe exhaust of air release valves to suitable disposal point.
- G. Pipe venting of manhole structures to suitable discharge point.
- H. Maintain ten foot horizontal separation of water main from sewer piping.
- I. Install ductile iron piping and fittings to AWWA C600 standards.
- J. Protect water utility distribution equipment from lateral displacement by placing embedment evenly on both sides of pipe.
- K. Do not lay water utility distribution equipment in water. Do not lay pipe under unsuitable weather or trench conditions.
- L. Establish elevations of buried equipment to ensure not less than 6 feet and not more than 8 feet of cover.
- M. Provide polyethylene tube encasement on all buried DIP fittings, valves and rodding to comply with AWWA C105.

N. Metal Surfaces

1. Apply coal tar coating on all steel clamp rods, bolts, and other metal accessories used in anchorages, cut ends of pipe, follower rings and bolts or joint harnesses subject to submergence or contact with the earth and not concrete encased, including pipe fittings and bolts in polyethylene tube protection
2. Apply 2 coats of coal tar paint to clean, dry metal surfaces

O. Tracer Wire and Tracer Wire Termination

1. Tape tracer wire to pipe every 8 to 10 feet at 3 o'clock position. Tracer wire to be placed in same orientation to all installed pipe.
2. Install splice connections such that no uninsulated wire is exposed. Direct bury tracer wire connectors. Do not twist wires together and wrap with electrical tape.
3. All mainline tracer wires to be interconnected in intersections, tees, and crosses. At tees, use 3-way lockable connector for all three tracer wires. At crosses, use 4-way lockable connector for the four tracer wires.
4. If two or more valves are located at a junction, and within a radius of no greater than 10 feet of one another, the tracer wire may be connected underground, and one test station provided at the northeast corner of the road intersection.
5. Strip 1 inch of protective coating from end of wire and attach to transmitter direct connect terminal on tracer wire test station lid.
6. Provide enough tracer wire so that a minimum of 12 inches and a maximum of 18 inches of wire can be accessed from above grade.
7. Coil tracer wire and place within the base section, below lid.
8. Install ground wire and magnesium anode, then attach to ground terminal on tracer wire test station lid. Terminate tracer wire at test station direct connect terminal.
9. When applicable, terminate tracer wire at valve cans by installing between the riser or base section (whichever is higher) and the top section.
10. Install pipeline marker tape approximately 12" above top of pipe.
11. Install minimum 6" concrete neck around lid at grade when outside of pavement.
12. Perform conductivity or locate test upon completion.

P. Backfill trench in accordance with Section 31 00 00.

Q. Protect piping systems from entry of foreign materials using temporary covers on completed sections of the work, and when isolating parts of completed system.

3.5 FIELD QUALITY CONTROL

A. Hydrostatic testing as specified in Section 33 11 00.

B. Ensure proper operation of all valves, hydrants, and curb stops.

END OF SECTION

33 13 00
DISINFECTION OF WATER UTILITY DISTRIBUTION

PART 1 GENERAL**1.1 SUMMARY**

- A. Section Includes
 - 1. Distribution of potable water utility distribution piping and equipment.
 - 2. Dechlorination of chlorinated discharge from distribution lines after disinfection.
 - 3. Testing and reporting results of disinfection.
- B. Related Sections
 - 1. 33 11 00 – Water Utility Distribution Piping
 - 2. 33 13 00 – Water Utility Distribution Equipment

1.2 REFERENCES

- A. Reference Standards
 - 1. ANSI/AWWA B300—Standard for Hypochlorites
 - 2. ANSI/AWWA B301—Standard for Liquid Chlorine
 - 3. ANSI/AWWA C651—Standards for Disinfecting Water Mains
 - 4. NSF 60—Drinking Water Treatment Chemicals - Health Effects

1.3 ACTION SUBMITTALS

- A. Test Reports: Indicate results comparative to specified requirements.
- B. Certificate: Certify that cleanliness of water distribution system meets or exceeds specified requirements.

1.4 PROJECT RECORD DOCUMENTS

- A. Submit under provisions of Section 01 70 00.
- B. Disinfection report; record:
 - 1. Type and form of disinfectant used.
 - 2. Date and time of disinfectant injection start and time of completion.
 - 3. Test locations.
 - 4. Initial and 24-hour disinfectant residuals (quantity in treated water) in ppm for each outlet tested.
 - 5. Date and time of flushing start and completion.
 - 6. Disinfectant residual after flushing in ppm for each outlet tested.
- C. Bacteriological report; record:

1. Date issued, project name, and testing laboratory name, address, and telephone number.
2. Time and date of water sample collection.
3. Name of person collecting samples.
4. Test locations.
5. Initial and 24-hour disinfectant residuals in ppm for each outlet tested.
6. Coliform bacteria test results for each outlet tested.
7. Certification that water conforms, or fails to conform, to bacterial standards of Colorado Department of Public Health and Environment.
8. Bacteriologist's signature and authority.

1.5 QUALITY ASSURANCE

- A. Perform Work in accordance with ANSI/AWWA C651 and C652.

1.6 QUALIFICATIONS

- A. Testing Firm: Company specializing in testing potable water systems, certified by the State of Colorado.

1.7 REGULATORY REQUIREMENTS

- A. Conform to applicable local code or state regulation for performing the work of this Section.

PART 2 PRODUCTS

2.1 DISINFECTION CHEMICALS

- A. Chemicals: ANSI/AWWA B300, Hypochlorite, ANSI/AWWA B301, Liquid Chlorine.

PART 3 EXECUTION

3.1 EXAMINATION

- A. Verify that piping system has been cleaned, inspected, and pressure tested
- B. Perform scheduling and disinfection activity with start-up, testing, adjusting and balancing, demonstration procedures, including coordination with related systems
- C. Complete disinfection after passing pressure tests

3.2 PRESSURE TESTING AND DISINFECTION

- A. Provide and attach required equipment to perform the work of this Section.

- B. Pressure test system under provisions of Section 33 11 00 prior. Repair leaks and re-test.
- C. Inject or place treatment disinfectant, free chlorine in liquid or granular form into piping system to obtain 50 to 80 mg/L residual.
- D. Bleed water from outlets to ensure distribution and test for disinfectant residual.
- E. Maintain disinfectant in system for 24 hours.
- F. If final disinfectant residual tests less than 25 mg/L, repeat treatment
- G. Flush, circulate and clean until residual equal to or less than 1.0 mg/L; use municipal domestic water.
- H. Take samples after completion of flushing, from outlets and from water entry, and analyze.

END OF SECTION

33 19 00
WATER UTILITY STRUCTURES

PART 1 GENERAL**1.1 SUMMARY**

- A. Section Includes
 - 1. Modular precast concrete manhole sections with tongue-and-groove joints, transition, frame, cover, anchorage, and accessories.
- B. Related Sections
 - 1. 03 30 00 – Concrete
 - 2. 03 60 00 – Grout
 - 3. 33 11 00 – Water Utility Distribution Piping
 - 4. 33 13 00 – Water Utility Distribution Equipment

1.2 REFERENCES

- A. Referenced Standards
 - 1. ASTM A48 – Gray Iron Castings
 - 2. ASTM A185 – Steel Welded Wire Fabric, Plain, for Concrete Reinforcement
 - 3. ASTM A615 – Deformed and Plain Billet-Steel Bars for Concrete Reinforcement
 - 4. ASTM C33 – Concrete Aggregate
 - 5. ASTM C150 – Portland Cement
 - 6. ASTM C478 – Precast Reinforced Concrete Manhole Sections
 - 7. ASTM C913 – Precast Concrete Water and Wastewater Structures
 - 8. ASTM C923 – Resilient Connectors Between Reinforced Concrete Manhole Structures and Pipes
 - 9. ASTM D4976 – Standard Specification for Polyethylene Plastic Molding and Extrusion Materials

1.3 ACTION SUBMITTALS

- A. Submit under provisions of Section 01 30 00.
- B. Shop Drawings: Indicate manhole location, internal barrel diameter, rim and elevations, size and locations of rough openings for pipe penetrations, type of base, heights of all precast sections, wall thickness, and conformance to material specifications.
- C. Product Data: Provide manhole covers, component construction, features, configuration, and pipe penetration gaskets.

1.4 QUALIFICATIONS

- A. Manufacturer: Company specializing in manufacturing products specified in this section with minimum 5 years of experience.

PART 2 PRODUCTS

2.1 MATERIALS

- A. Concrete: Section 03 30 00 except as modified herein.
 - 1. Minimum compressive strength: 4000 psi at 28 days.
 - 2. Cement: ASTM C150, Portland Cement, Type II.
 - 3. Aggregates: ASTM C33, free of deleterious substances.
- B. Reinforcement: Section 03 30 00
- C. Bedding: 3/4" minus graded gravel as specified in Section 31 00 00.
- D. Loading: AASHTO HS-20

2.2 STRUCTURAL BEAMS

- A. Description
 - 1. Dimensions: 12 inches by 12 inches by 8 feet long
 - 2. Lifting Hooks: 2 per beam
 - 3. Reinforcement
 - a. Three (3) No. 6 Grade 60 Continuous @ 3 inches on center
 - b. No. 4 Grade 60 @ 18 inches on center
 - c. 3 inches minimum clearance from rebar to outside face of concrete.

2.3 PRECAST STRUCTURAL FOOTINGS AND BASE SECTIONS

- A. Description
 - 1. Dimensions: per plan
 - 2. Monolithically cast footing/floor and first section of wall (24" high min.)
 - 3. Reinforcement
 - a. Conform to ACI 318, latest edition for reinforcing code requirements

2.4 PRECAST RISER SECTIONS

- A. Description
 - 1. Shape: Cylindrical or rectangular as shown on plans
 - 2. Internal Diameter Internal Dimensions: As shown on plans
 - 3. Specification: ASTM C478
 - 4. Wall thickness: 5 inches minimum
 - 5. Reinforcement: Welded wire fabric, ASTM A185
 - 6. Access/ladder steps per OSHA standards

7. Section Height
 - a. 12 inches minimum
 - b. 60 inches maximum
8. Joint: Tongue and Groove

2.5 PRECAST LID

- A. Description
 1. Shape: Flat
 2. Access Opening: 24 inches clear or as shown on plans
 3. Specifications: ASTM C478
 4. Thickness: 12 inches minimum
 5. Reinforcement: Welded wire fabric, ASTM A185
 6. Joint: Tongue and Groove

2.6 ACCESSORIES

- A. Grade Adjustment Rings
 1. High Density Polyethylene
 - a. Specification: ASTM D-4976
 - b. Manufactured using injection molded process.
 - c. Use slope adjustment ring(s) as needed to adjust for finished grade.
 - d. Manufacturer and Product:
 - 1) Ladtech Round Grade Adjustment Rings
 - 2) Or accepted equal
 2. Grade Ring Sealant
 - a. Butyl sealant.
 3. Do not use grout on manhole grade adjustment rings.
 4. Do not use precast concrete grade rings.
- B. Standard Ring and Cover
 1. Cast iron, heavy duty traffic type, ASTM A48, Class 35B. Grind bearing surfaces to ensure flat, true surfaces.
 2. Covers to seat at all points on ring.
 3. Words " WATER" in flushed boss letters cast in center of lid.
 4. Raised lugs.
 5. Open edge pry.
 6. Manufacturer and Product
 - a. D&L Supply A-1075
 - b. Deeter Foundry 1256
 - c. Castings Inc. MH-310-24
 - d. Or approved equal
- C. Lockdown Ring and Cover
 1. As specified above except as follows:

- a. Provide ring and cover with four tapped holes, and 4 stainless steel penta-head bolts to secure ring to cover.

PART 3 EXECUTION

3.1 EXAMINATION

- A. Verify items provided by other section of Work are properly sized and located.
- B. Verify that built-in items are in proper location, ready for roughing into Work.
- C. Verify excavation for manholes is correct.

3.2 PREPARATION

- A. Excavate and prepare subgrade per Section 31 00 00.
- B. Coordinate placement of inlet and outlet pipe or duct sleeves required by other sections.
- C. Rock Base: Place $\frac{3}{4}$ " rock 12 inches minimum depth, vibrate for compaction.

3.3 INSTALLATION

- A. Place structural beams
 1. Set beams plumb and level and at proper elevation.
 2. Lower onto gravel base using lifting hooks.
 3. Place longitudinally and parallel to pipeline alignment.
 4. Beams centered on vault center.
 5. Install such that clear distance between inside faces of beams is 3 feet.
 6. Bottom of beams at same elevation as top of pipe.
- B. Place Precast Barrel Sections
- C. Place Precast Lid
- D. Place Grade Rings
 1. 4" total thickness minimum
 2. 8" total thickness maximum
 3. No grade rings for off-pavement manholes.
- E. Place Ring and Cover
 1. Finished elevation compared to adjacent grade
 - a. Pavement
 - 1) $\frac{1}{2}$ inch minimum
 - 2) 1 inch maximum
 - b. Not Pavement

- 1) 8" minimum
- 2) 28" maximum

END OF SECTION

33 31 00
SANITARY UTILITY SEWERAGE PIPING

PART 1 GENERAL**1.1 SUMMARY**

- A. Section Includes
 - 1. Polyvinyl chloride (PVC) sanitary sewer pipe with all jointing materials, fittings, and other appurtenances required for installation
- B. Related Sections
 - 1. Section 31 00 00 – Earthwork
 - 2. Section 33 39 00 – Sanitary Utility Sewerage Structures

1.2 REFERENCES

- A. Reference Standards
 - 1. ASTM D1784 – Rigid Poly (Vinyl Chloride) (PVC) Compounds and Chlorinated Poly (Vinyl Chloride) (CPVC) Compounds
 - 2. ASTM D2321 – Practice for Underground Installation of Flexible Thermoplastic Sewer Pipe
 - 3. ASTM D3034 – TYPE PSM Poly (Vinyl Chloride) (PVC) Sewer Pipe and Fittings
 - 4. ASTM D3212 – Joints for Drain and Sewer Plastic Pipes Using Flexible Elastomeric Seals
 - 5. ASTM F477 – Elastomeric Seals (Gaskets) for Joining Plastic Pipe
 - 6. ASTM F679 – Poly (Vinyl Chloride) (PVC) Large Diameter Plastic Gravity Sewer Pipe and Fittings

1.3 ACTION SUBMITTALS

- A. Submit under provisions of Section 01 30 00.
- B. Product Data: Provide data on pipe and gasket materials, pipe fittings, and accessories. Provide manufacturer's catalog information with recommended installation requirements
- C. Manufacturer's Certificate: Certify that products meet or exceed specified requirements and applicable standards
- D. Test Reports: Submit reports of air test, deflection test, Closed Circuit Television under provisions

1.4 PROJECT RECORD DOCUMENTS

- A. Submit under provisions of Section 01 70 00.

- B. Accurately record actual locations of pipe, pipe fittings, and invert elevations
- C. Identify and describe unexpected variations to subsoil conditions or discovery of uncharted utilities.
- D. Note locations of dewatering activities.
- E. Note locations of any placement of trench stabilization material.

1.5 DELIVERY, STORAGE AND HANDLING

- A. Deliver, store, and handle with care.
- B. Handle to ensure installation in sound, undamaged condition. Do not damage the pipe by impact, bending, compression or abrasion during handling or storage.
- C. Use equipment, tool, and methods for unloading, reloading, hauling, and laying that do not damage pipe.
 - 1. Use hooks/hands with broad, well-padded contact surfaces for insertion into pipe ends or nylon protected slings to handle pipe.
 - 2. Do not use unpadded hooks or bare cables.
- D. Store pipe on a flat surface which provides even support for the barrel with bell ends overhanging.
 - 1. Do not stack pipe higher than 5 feet.
- E. Do not store pipe and materials uncovered in direct sunlight, and do not use pipe and fittings that have been stored in direct sunlight for periods in excess of 18 months.
- F. Ship rubber gaskets in cartons and store in a clean area away from grease, oil, ozone producing electric motors, heat and the direct rays of the sun.
- G. Replace pipe and fittings where lining is split, broken, or loosened.
- H. District may permit Contractor to repair small, readily accessible damaged areas of lining in accordance with manufacturer's instructions.

1.6 REGULATORY REQUIREMENTS

- A. Conform to all municipal, district codes and ordinances, laws and regulations of the state.
- B. In case of apparent conflict, state and local requirements govern over these specifications.

PART 2 PRODUCTS

2.1 SANITARY SEWER MAIN PIPE AND FITTINGS

- A. Plastic
 - 1. Manufacturers
 - a. JM Eagle
 - b. North American Pipe Corporation
 - c. Or accepted substitution.
 - 2. Pipe and Fittings
 - a. Specification: ASTM D3034, Schedule 40, SDR 35 and SDR 26
 - b. Type: PSM
 - c. Cell classification: ASTM D1784, 12454-B, 12454-C, or 13364-B
 - d. Pipe length: manufacturer's standard lengths.
 - e. Diameter: 8 inches minimum
 - f. Shall not be used in conjunction with pipeline deflection
 - 3. Joints: Push on, ASTM D3212 and F477
 - a. Integral bell, bell and spigot rubber gasketed joint, ASTM D3212 & F477
 - b. Internally cast bell with one sealing ring
 - c. Designed to hold pipe in alignment, provide flexibility, separate the ends of pipe lengths, resist applied earth pressures, and provide fluid tightness
 - d. Visible "stop marks"
 - e. Rubber rings: ASTM D3212 and F477
- B. Cast Iron
 - 1. Manufacturers
 - a. Submit All Manufacturers for Review
 - 2. Pipe
 - a. Cast Iron Soil Pipe, ASTM A74, extra heavy or service type, bell and spigot or plain end.
 - b. Cast Iron Soil Pipe Fitting – ASTM C564 or CISPI Standard 310
 - c. Diameter: 8 inches minimum

2.2 SANITARY SEWER SERVICE LINE PIPE AND FITTINGS

- A. Any material specified for Sanitary Sewer Main Pipe and Fittings.
- B. Plastic
 - 1. Manufacturers
 - a. JM Eagle
 - b. North American Pipe Corporation
 - c. Or accepted substitution.
 - 2. Pipe and Fittings
 - a. Specification: ASTM D1875, Schedule 40 and 80
 - b. Pipe length: manufacturer's standard lengths.
 - c. Diameter: 4 to 6 inches

3. Joints
 - a. Solvent Sealed Joint Glued
 - b. All pipe spigots must have noted stop marks

2.3 TRACER WIRE

- A. Manufacturers and Products
 1. Material: # 10 AWG copper clad steel, high strength with minimum 600 lb. break load.
 2. Coating: Minimum 30 mil HDPE insulation thickness for direct bury.
 3. Color: Blue
 4. Connectors: Moisture displacement and corrosion resistant connectors.
 - i. Copperhead Snakebite
 - ii. 3M DBR
 - iii. Or approved substitution
- B. Terminal Stations
 1. Copperhead 2" two-terminal switchable lid, model SP-SWLID-*2 or approved substitution
 2. Color: Blue
 3. Text: WATER
 4. Installed at minimum every 500 feet along pipeline, and at all fire hydrants and water valves.
- C. Grounding
 1. Magnesium anode, 1.5 pounds minimum, securely grounded and connected to terminal lid

2.4 ACCESSORIES

- A. Pipeline Marker Tape
 1. Width: 6 inches minimum
 2. Thickness: 5 mil minimum
 3. Color: Green
 4. Backing: Aluminum
 5. Printing: "Caution Buried Sewer Line Below"
- B. Sanitary Sewer Service Connection
 1. "In Line" Wye
 - a. Wye fitting with gasketed joint per Sanitary Sewer Main Pipe and Fittings.
 - b. Schedule
 - 1) For use when installing proposed service line connections to proposed mains. (New Construction)
 2. Saddle Tap
 - a. Manufacturer

- 1) Geneco
- 2) Or Accepted Substitution
- b. Product
 - 1) Sealtite Multi Range Sewer Saddle
 - 2) Configuration: Wye or Tee
 - 3) Model:
 - a) Wye: Type E
 - b) Tee: Type U
 - 4) Base: ASTM A-48 Class 30 Cast Iron dip-coated in water-based bituminous coating
 - 5) Gasket: O-Ring ASTM C-367-77 Tubular Polyisoprene
 - 6) PVC Adapter: ASTM D-3034 SDR-35 gasketed bell cemented to cast iron base with two-part urethane adhesive
 - 7) Strap: One 24-gauge 2.5-inch wide Type 304 Stainless Steel
 - 8) Strap Pins: 0.75-inch diameter Type 303 Stainless Steel
 - 9) T-Bolts: 0.375-inch diameter-16 Type 304 Stainless Steel
 - 10) Nuts and Washers: Type 18-8 Stainless Steel
- c. Schedule
 - 1) For use when connecting to existing mains.

2.5 SOURCE QUALITY CONTROL

- A. Identification Marks: Clearly and permanently marked at not greater than 5-foot intervals with pipe diameter, PVC cell classification, manufacturer, plant, shift, ASTM, SDR, date designation, and service designation.
- B. Testing per ASTM D3034
 1. Test products not manufactured in the U.S. at an acceptable laboratory in the U.S.

PART 3 EXECUTION

3.1 INSPECTION

- A. Examine pipe and fittings and do not use individual sections containing cracks, dents, abrasions, and other defects.
- B. Mark rejected pipe and remove from the site.

3.2 INSTALLATION

- A. Install pipe in accordance with ASTM D2321 as modified herein or on the drawings.
- B. Remove defective material from the site as directed by District
- C. Excavate and Bed the pipe per provisions of Section 31 00 00.

D. Cutting

1. Cut and bevel ends in accordance with manufacturer's standard recommendations.
2. Machine cut ends smooth and square to proper dimensions.
3. Do not cut with a cold chisel, iron pipe cutter, flame or any other method that may fracture the pipe or leave ragged, uneven edges.
4. Remove burrs and wipe off all dust and dirt from jointing surfaces.

E. Pipe Laying

1. Inspect pipe and accessories for defects before lowering into trench.
2. Repair or replace any defective, damaged, or unsound pipe.
3. Remove all dirt and foreign material from the inside of pipe before installation.
4. Check bedding for firmness and uniformity of surface immediately before installing each section of pipe.
5. Carefully lower pipe, fittings, valves, and accessories into the trench with derricks, ropes, and other suitable equipment to prevent damage.
6. Do not dump or drop pipe or accessories into trench.
7. Install to lines and grades indicated on drawings or as specified.
 - a. Closely joint to form a smooth flow line.
 - b. Maximum length of pipe that can be used without exceeding the allowable pipe deflection, as specified by the manufacturer, shall be determined.
 - c. Maximum radius of curvature as recommended by the manufacturer or as specified by District, whichever is greater.
 - d. Joint deflection is **not allowed**.
 - e. Check pipe for "crowning" and install crown up.
8. Utilize implements, tools, and facilities as recommended by the manufacturer.
9. Keep pipe clean during and after laying.
10. Close all open ends with watertight expandable type sewer plugs or test plugs.
11. Remove and relay any pipe which has floated.
12. Do not lay pipe when.
 - a. There is water in the trench.
 - b. Trench conditions are unsuitable.
 - c. Weather conditions are unsuitable.
13. Use acceptable adaptors at manhole and structure connections to provide a watertight seal and flexibility; provide a short length of pipe outside each connection.
14. Protect from lateral displacement.

F. Jointing

1. Assemble in accordance with the manufacturer's instructions.
2. Wipe clean pipe ends, gasket, and gasket groove before inserting gasket.

3. Apply lubricant furnished by the pipe manufacturer to the gasket and the outside of the spigot end.
 4. Utilize an assembly tool as recommended by the manufacturer to center the sleeve over the spigot end.
 5. Insert the spigot end to the reference mark.
 6. Check gasket location after assembly with a suitable gage.
 - a. Gasket locations to be the distance from the sleeve and recommended by the coupling manufacturer for their full circumference.
 - b. If not within the required limits, disassemble and reassemble the joint.
- G. Fittings
1. Install utilizing standard methods.
 2. Lower into trench with rope, cable, chain, or other means to prevent damage.
 3. Attach rope, cable or chain around the exterior.
 4. Do not attach rope, cable or chain through the interior.
 5. Carefully connect to pipe or other facility.
 6. Check joint to ensure a sound and proper joint.
- H. Backfill and compact per Section 31 00 00.
- I. Install pipeline marker tape on top of pipe bedding.

3.3 FIELD QUALITY CONTROL

- A. Air Test
1. Perform an air test on each reach of sewer or drain pipe between manholes:
 - a. Provide all necessary piping between the reach to be tested together with all required materials and equipment.
 - b. Methods used, scheduling, and duration of tests shall be acceptable to District.
 - c. Low pressure air testing on 100 percent of system:
 - 1) Submit complete information to District for review describing the proposed test method of water exfiltration testing manholes before beginning air testing
 - 2) Preparation for test: Flush and clean the sewer line prior to testing to wet the pipe surfaces and produce more consistent results. Plug and brace all openings in the main sewer line and upper connections. Check all pipe plugs with a soap solution to detect any air leakage. If leaks are found, release the air pressure, eliminate the leaks, and start the test procedure over again.

- 3) Procedure of test: Add air until the internal pressure of the sewer line is raised to approximately 4.0 psi gage at which time the flow of air shall be reduced and the pressure maintained between 3.5 and 4.5 psig for a sufficient time to allow the air temperature to come to equilibrium with the temperature of the pipe.
- 4) After the temperature has stabilized, permit the pressure to drop to 3.6 psig more than the ground water pressure above the top of the sewer.
- 5) The portion being tested is passing if it does not lose air at a rate to cause the pressure to drop from 3.6 to 3.0 psig (greater than the average back pressure of any ground water that may submerge the pipe) in less time than listed in Table 1 - 33 31 00, below.

PIPE DIAMETER (inches)	MINIMUM ALLOWABLE TIME (Min:Sec) 3.6-3.0 psig
4	0:50
6	1:10
8	1:40
10	2:00
12	2:20

Table 1 - 33 31 00: Minimum time for low-pressure pipe air testing

- 6) Brace all plugs sufficiently to prevent blowouts and vent the pipeline completely before attempting to remove the plugs.
- 7) Provide pressurizing equipment with a relief valve set at 5 psi to avoid over pressurizing and damaging an otherwise acceptable line.
- d. Conduct smoke test to detect leaks if the air test fails to meet specified limits.
- e. Pipelines shall not have any visible leaks or damp spots.
- f. Repair and retest lines that fail tests until satisfactory results are obtained.

B. Pipe Deflection Test

- 1. No sooner than 30 days after placement and compaction of backfill, but prior to placement of permanent surface materials, clean and mandrel each

line to detect obstructions (deflections, joint offsets, lateral pipe intrusions, etc.).

2. Use a rigid mandrel with diameter of at least 95 percent of the pipes specified average inside diameter and a length of the mandrel circular portion at least equal to the nominal pipe diameter.
3. Maximum allowable deflection is 5 percent of the base internal diameter. Mandrel outside diameters in inches are listed in Table 2 – 33 31 00, below.

PIPE SIZE (INCHES)	BASE ID (INCHES)	MANDREL OD (INCHES)
6	5.792	5.50
8	7.764	7.38
10	9.711	9.23
12	11.558	10.98

Table 2 - 33 31 00: Mandrel Testing

4. Pull the mandrel through the pipe by hand.
5. Relay or replace all pipe which does not allow mandrel to freely pass through the pipe section.
6. Retest repaired sections.
7. Owner/District shall be present and witness mandrel testing.
8. Test results from a neutral third-party testing agency are acceptable.

C. Closed Circuit Television (CCTV) Inspection

1. After backfilling of the sewer lines but prior to placing lines into service or connecting to the District’s sewer collection system, Contractor shall conduct a CCTV inspection on every reach of sewer and manhole installed.
2. CCTV inspection shall be conducted by a third-party organization specializing in such work and acceptable to the District. Contractor shall coordinate and pay all cost associated with CCTV Inspections.
3. Procedure and Visual Data Required:
 - a. Contractor shall continuously add water (after flushing and cleaning of the line) to the pipeline segment being inspected immediately preceding the commencement of CCTV inspection.
 - b. Insert camera and record the following minimum requirements (such requirements shall show visually on the screen of the video):
 - 1) Running slope (by inclinometer) along entire reach being recorded.
 - 2) Eccentricity diagram showing pipe eccentricity along the entire reach being recorded.
 - 3) Reach number (i.e. “reach 1” and so on) with “from” and “to” manhole numbers or designations.

- 4) Odometer reading in feet as the camera travels down each reach. Each run shall be calibrated and start at an odometer reading of zero feet at the exterior wall of each beginning manhole.
- 5) Camera shall stop briefly at each service line entry, low point, manhole entry and manhole exit.
- c. Electronic Media
 - 1) Deliver to the District each video recorded. Videos shall be submitted on digital media format only and be supplied on DVD or other electronic media acceptable to the District.
 - 2) Upon review of video inspections by the District, contractor shall be notified of any deficiencies observed. Contractor shall promptly correct any deficiencies, retest, and perform video re-inspection until satisfactory results are obtained.
4. The following shall be considered deficiencies and shall be corrected prior to conditional and final acceptance:
 - a. Pipelines 12 inches in diameter or less with sags exceeding 1/2-inches in depth will not be accepted. Pipeline Sags that are less than 1/2-inch in depth shall be noted at time of preliminary acceptance and if, at the time of CCTV for final acceptance, the sag has increased in size the contractor shall repair the sag. This determination shall be made solely by District staff.
 - b. Any connections, such as service taps, where material extends past the inside diameter of the pipe mainline.
 - c. Debris.
 - d. Deformations and damage.
 - e. Joint defects, such as rolled or improperly compressed gaskets.
 - f. Out of round greater than approximately 5% of the pipe diameter.
 - g. Over insertion of a bell.
 - h. Improperly sized connections.
 - i. Any other defect as identified by District personnel.

3.4 CLEANING

- A. Prior to conditional acceptance, remove all accumulated construction debris, rocks, gravel, sand, silt, and other foreign material from the sewer system. Use mechanical rodding or bucketing equipment as required
- B. Prior to final inspection, if any foreign matter is present in the system, flush and clean the sections of the line as required

END OF SECTION

33 39 00
SANITARY SEWERAGE UTILITY STRUCTURES

PART 1 GENERAL**1.1 SUMMARY**

- A. Section Includes
 - 1. Modular precast concrete manhole sections with tongue-and-groove joints, monolithic base, transition, ring, cover, anchorage, and accessories.
- B. Related Sections
 - 1. 03 30 00 – Concrete
 - 2. 03 60 00 – Grout
 - 3. 07 11 13 – Bituminous Damproofing
 - 4. 33 31 00 – Sanitary Utility Sewerage Piping

1.2 REFERENCES

- A. Referenced Standards
 - 1. ASTM A48 – Gray Iron Castings
 - 2. ASTM A185 – Steel Welded Wire Fabric, Plain, for Concrete Reinforcement
 - 3. ASTM A615 – Deformed and Plain Billet-Steel Bars for Concrete Reinforcement
 - 4. ASTM C33 – Concrete Aggregate
 - 5. ASTM C150 – Portland Cement
 - 6. ASTM C478 – Precast Reinforced Concrete Manhole Sections
 - 7. ASTM C877 – Standard Specification for External Sealing Bands for Concrete Pipe, Manholes, and Precast Box Sections
 - 8. ASTM C913 – Precast Concrete Water and Wastewater Structures
 - 9. ASTM C923 – Resilient Connectors Between Reinforced Concrete Manhole Structures and Pipes
 - 10. ASTM D2240 – Standard Test Method for Rubber Property-Durometer Hardness
 - 11. ASTM C990 - Standard Specification for Joints for Concrete Pipe, Manholes, and Precast Box Sections Using Preformed Flexible Joint Sealants
 - 12. ASTM D4976 – Standard Specification for Polyethylene Plastic Molding and Extrusion Materials

1.3 ACTION SUBMITTALS

- A. Submit under provisions of Section 01 30 00.

- B. Shop Drawings: Indicate manhole location, internal barrel diameter, rim elevation, size, and locations of rough openings for pipe penetrations, type of base, heights of all precast sections, wall thickness, and conformance to material specifications.
- C. Product Data: Provide manhole covers, component construction, features, configuration, and pipe penetration gaskets.

1.4 QUALIFICATIONS

- A. Manufacturer: Company specializing in manufacturing products specified in this section with minimum 5 years of experience.

PART 2 PRODUCTS

2.1 MATERIALS

- A. All products specified are for use with raw wastewater.
 - 1. Water temperature range: 5° C to 25° C.
- B. Concrete: Section 03 30 00 except as modified herein.
 - 1. Minimum compressive strength: 4000 psi at 28 days.
 - 2. Cement: ASTM C150, Portland Cement, Type II.
 - 3. Aggregates: ASTM C33, free of deleterious substances.
 - 4. Water: Clean and free of deleterious substances.
- C. Reinforcement: Section 03 30 00
- D. Loading: AASHTO HS-20

2.2 PRECAST SECTIONS

- A. Manufacturer
 - 1. Firebaugh Precast
 - 2. Or accepted substitution.
- B. Description
 - 1. Shape: Cylindrical
 - 2. Internal Diameter: 4 feet minimum
 - 3. Specification: ASTM C478
 - 4. Wall thickness: 5 inches minimum
 - 5. Wall reinforcement: Welded wire fabric, ASTM A185
 - 6. No steps.
 - 7. Joints: Tongue and Groove
- C. Precast Base
 - 1. Base and first riser section monolithically poured.

- a. Riser height:
 - 1) 24 inches minimum
 - 2) 48 inches maximum
 - b. Base slab reinforcement
 - 1) No. 4 Grade 60 at 12 inches on center each way
 - 2) Thickness: 8 inches minimum
- D. Precast Riser Sections
- a. Section Height
 - 1) 12 inches minimum
 - 2) 60 inches maximum
- E. Precast Lid
- 1. Description
 - a. Shape:
 - 1) Flat lid for manholes with a total riser height of less than 6 feet.
 - 2) Eccentric cone for manholes with a total riser height of 6 feet or greater.
 - b. Access Opening:
 - 1) 24 inches clear
 - 2) Offset from center of manhole
 - c. Flat Lid Thickness: 12 inches minimum
 - d. Eccentric cone heights
 - 1) 24 inches
 - 2) 30 inches
 - 3) 32 inches
 - 4) 36 inches
 - e. Eccentric cone reinforcement: Welded wire fabric, ASTM A185
 - f. Flat lid reinforcement:
 - 1) No. 4 Grade 60 at 12 inches on center each way.
 - 2) No.4 Grade 60 hoop around access opening.

2.3 ACCESSORIES

- A. Bedding: 3/4 inch minus graded gravel as specified in Section 31 00 00.
- B. Pipe Penetration Gaskets
 - 1. Manufacturer and Product
 - a. Press Seal Gasket Corp. PSX Direct Drive
 - b. Trelleborg NPC Kor-N-Seal 106/406 Series
 - c. Hamilton Kent Tylox MIB Series
 - d. Or approved equal
 - 2. Description
 - a. Specification:
 - 1) Overall conformance to ASTM C923.

- 2) Rubber conforms to ASTM D2240, No.40 durometer A.
 - b. Stainless steel adjustable pipe clamps and bolts.
- C. Grout: Provide under provisions of Section 03 60 00.
- D. Joint Gaskets
 1. Manufacturer and Product
 - a. Press-Seal Gasket Corporation EZ-Stik Premium Butyl Sealant
 - b. Henry Rub'R Nek RU106
 - c. Hamilton Kent Kent-Seal Butyl Sealant
 2. Description
 - a. Preformed flexible joint sealant.
 - b. Specification: ASTM C990
 - c. Type: Rope coil.
Diameter: 1 inch
 3. Do not use grout on interior riser joints
- E. External Joint Wrap
 1. Manufacturers and Products
 - a. Henry RubR-Nek RU116
 - b. Press Seal Gasket Corporation EZ-Wrap
 - c. or approved equal
 2. Description
 - a. Specifications: ASTM C-877, Butyl Rubber w/EPDM Lining
 - b. Minimum width: 6 inches
- F. Joint Primer
 1. Prime all exterior joints.
- G. Exterior Damproofing
 1. Installed on exterior surfaces of all precast concrete manhole sections per the provisions of Section 07 11 13.
- H. Grade Adjustment Rings
 1. High Density Polyethylene
 - a. Specification: ASTM D-4976
 - b. Manufactured using injection molded process.
 - c. Use slope adjustment ring(s) as needed to adjust for finished grade.
 - d. Manufacturer and Product:
 - 1) Ladtech Round Grade Adjustment Rings
 - 2) Or accepted equal
 2. Pre-Cast Concrete
 - a. Specification: ASTM C-478
 - b. 4 inches minimum thickness
 - c. Manufacturer and Product:
 - 1) Firebaugh Precast

- 2) Or accepted equal
 3. Grade Ring Sealant
 - a. Butyl sealant.
 4. Do not use grout on manhole grade adjustment rings.
- I. Standard Ring and Cover
1. Manufacturer and Product
 - a. D&L Supply A-1075
 - b. Deeter Foundry 1256
 - c. Castings Inc. MH-310-24
 - d. Or approved equal
 2. Description
 - a. Type: Cast iron, heavy duty traffic type, Class 35B.
 - b. Specification: ASTM A48 with asphalt varnish coating hot dip applied at foundry, 6-10 mils thick.
 - c. Lettering: "SEWER" in flushed boss letters cast in center of lid.
 - d. Cover Finish: Raised lugs.
 - e. Lift Type: Open edge pry with pick hole.
 - f. Grind bearing surfaces to ensure flat, true surfaces.
 - g. Covers to seat at all points on ring.
 - h. Use watertight assembly in surface drainage areas.
- J. Lockdown Ring and Cover
1. As specified for Standard Ring and Cover except as follows:
 - a. Provide ring and cover with four tapped holes, and 4 stainless steel penta-head bolts to secure ring to cover.

2.4 FABRICATION

- A. Shop-apply damp proofing on all exterior surfaces of manholes under the provisions of Section 07 11 13.
- B. All joints to be primed with a product compatible with the type of joint gasket to be used.
- C. Base
1. Extended base with riser wall to be monolithically poured.
 2. Include circular holdouts for pipe connections at locations specified on the plans.
- D. Channel and Inverts
1. Place concrete in bottom of manhole and form smooth transition.
 2. Slope bench 1 inch per foot for drainage to invert.
 3. Depth of channel is equal to pipe radius of outgoing pipe.
 4. Shape invert to conform to radius of pipe it connects.

5. Trowel smooth and brush for non-skid finish.
6. Fillet edges 1 inch.
7. Remove all rough sections or sharp edges which tend to obstruct flow or cause material to snag

PART 3 EXECUTION

3.1 EXAMINATION

- A. Verify items provided by other section of Work are properly sized and located.
- B. Verify that built-in items are in proper location, ready for roughing into Work.
- C. Verify excavation for manholes is correct.

3.2 PREPARATION

- A. Excavate and prepare subgrade per Section 31 00 00.
- B. Coordinate placement of inlet and outlet pipes required by other sections.
- C. Rock Base:
 1. Place 3/4-inch rock 6 inches minimum depth to 2 feet beyond edge of manhole base.
 2. Vibrate for compaction.

3.3 INSTALLATION

- A. Manhole Base
 1. Place manhole base and barrel section on rock sub-base plumb, level and at required elevations for receiving subsequent barrel sections.
- B. Connections to Existing Pipelines
 1. Bypass pump flows around the area where the new manhole will be placed. Cut and remove exiting PVC/VCP sewer line and slide precast base and riser section onto existing downstream side of pipe for existing PVC sewers. For existing VCP sewers, cut and remove pipe for 3 feet outside exterior face(s) of manhole.
 2. For PVC sewers, install Bell x PE spool from exist upstream side into new manhole. PE end of spool shall be the end inserted into the manhole and the bell shall be pushed onto the existing upstream side of the existing pipe. For VCP sewers install PE x PE (PVC) spools with PVC x VCP transition coupling from inside the new manhole to the existing VCP line(s).
 3. End bypass pumping once inverts have cured.
- C. All Joints between precast sections

1. Clean ends of sections and place single preformed plastic gasket for entire circumference of manhole joint.
 - a. Cut and butt ends per manufacturer recommendations.
 2. Install exterior joint wrap centered on joint.
- D. Barrel Sections
1. Place subsequent manhole sections plumb and level, trim to correct elevations.
- E. Precast Lid
1. Align access hole over the out invert of the manhole unless directed otherwise by the Plans or by the District.
- F. Field apply damp proofing of all exterior surfaces damaged by construction or installation under provisions of Section 07 11 13.
- G. Grade Rings
1. 4 inches total thickness minimum
 2. 8 inches total thickness maximum
 3. No grade rings for off-pavement manholes.
 4. Seal using
- H. Ring and Cover
1. Finished elevation compared to adjacent grade
 - a. In pavement
 - 1) 1/2 to 3/4 inches below
 - b. Not in pavement
 - 1) 18 inches above finished grade as projected at the centerline of the manhole with not less than 4 inches minimum above adjacent grade (high side) and no more than 28 inches maximum above adjacent grade (low side)

3.4 FIELD QUALITY CONTROL

- A. Vacuum test
1. Plug and seal all inlets and outlets.
 2. Install the vacuum tester head assembly on the manhole.
 3. Attach the vacuum pump assembly to the proper connection on the test head assembly. Make sure the vacuum inlet/outlet ball valve is in the closed position.
 4. Inflate the sealing element to twice the test pressure to be used. Do not over inflate.
 5. Start the vacuum pump assembly engine and allow preset RPM to stabilize.

6. Open the inlet/outlet ball valve and evaluate the manhole to 10 inches Hg. (mercury) which is equivalent to approximately 5 PSIG (0.3 bar) backpressure.
7. Close vacuum inlet/outlet ball valve, disconnect vacuum pump and monitor vacuum for 1 minute.
8. Allowable leakage: less than 1 inches Hg. in 1 minute.
9. If a manhole fails the initial test, make the necessary repairs by an approved method. Retest the manhole until a satisfactory test result is obtained.

END OF SECTION

APPENDIX B

STANDARD CONSTRUCTION DETAILS

GENERAL UTILITIES
TABLE OF CONTENTS

G-1 TABLE OF CONTENTS
 G-2 ABBREVIATIONS AND ACRONYMS
 G-3 TYPICAL UTILITIES LAYOUT (PLAN)
 G-4 TYPICAL UTILITIES LAYOUT (SECTION)
 G-5 TYPICAL SERVICES LAYOUT (PLAN)
 G-6 WATER SERVICE (3/4" TO 2")
 G-7 WATER SERVICE (2-1/2" TO 6")
 G-8 TYPICAL SEWER SERVICE
 G-9 METER SETTING SCHEMATIC
 G-10 IRRIGATION ONLY EXTERIOR METER PIT

[33 11 00]

W-1 TYPICAL WATER TRENCH SECTION
 W-2 (RESERVED)
 W-3 WATER CROSSING UNDER UTILITIES

[33 12 00]

W-4 GATE VALVE
 W-5 DEAD-END BLOW-OFF ASSEMBLY
 W-6 VALVE CANS IN UNPAVED AREAS
 W-7 HORIZONTAL AND VERTICAL BENDS
 W-8 FIRE HYDRANT ASSEMBLY
 W-9 WATER LOWERING BY FITTING
 W-10 WATER MAIN JUNCTION
 W-11 LENGTH OF RESTRAINED PIPE (PVC)
 W-12 LENGTH OF RESTRAINED PIPE (DIP)

[33 13 00]

W-13 AIR/VAC VAULT (PLAN)
 W-14 AIR/VAC VAULT (SECTION)
 W-15 MANHOLES IN PAVED AREAS
 W-16 MANHOLES IN UNPAVED AREAS
 W-17 STANDARD WATER RING & COVER
 W-18 LOCKDOWN WATER RING & COVER

[33 39 00]

S-1 SEWER TRENCH SECTION

[33 39 00]

S-2 SEWER ECCENTRIC CONE MANHOLE
 S-3 SEWER FLAT TOP MANHOLE
 S-4 SEWER DROP MANHOLE
 S-5 SEWER MANHOLE DETAILS
 S-6 SEWER MANHOLE STANDARD BASE
 S-7 SEWER MANHOLE HIGH VELOCITY BASE
 S-8 BASE GEOMETRY
 S-9 MANHOLES IN PAVED AREAS
 S-10 MANHOLES IN UNPAVED AREAS
 S-11 STANDARD SEWER RING & COVER
 S-12 LOCKDOWN SEWER RING & COVER
 S-13 CORE DRILLING INTO EXISTING MANHOLE

ABBERRIATIONS AND ACRONYMS LEGEND

ASSY	ASSEMBLY	PC	POINT OF HORIZONTAL CURVATURE
		PE	POLYETHYLENE
BNDY	BOUNDARY	PCHC	PC ON HORIZONTAL CURVE
B.O.P.	BOTTOM OF PIPE	PP, PR.	PROPOSED
BV	BUTTERFLY VALVE	PT	POINT OF HORIZONTAL TANGENCY
BLV	BALL VALVE	PTHC	PT ON HORIZONTAL CURVE
		PTW	POTABLE WATER MAIN
C&G	CURB & GUTTER	PVC	POLYVINYL CHLORIDE
☒	CENTERLINE	PVI	POINT OF VERTICAL INTERSECTION
CL	CLASS	PVT	POINT OF VERTICAL TANGENCY
CORP	CORPORATION		
CRA	CONCRETE REVERSE ANCHOR	RCB	REINFORCED CONCRETE BOX
CTRB	COUNTER THRUST BLOCK	RCP	REINFORCED CONCRETE PIPE
CR	POINT OF CURB RETURN	ROW	RIGHT OF WAY
		RSTNT	RESTRAINT
DET.	DETAIL	RT	RIGHT
DI	DUCTILE IRON		
DIA., ∅	DIAMETER	SAN	SANITARY SEWER
DIP	DUCTILE IRON PIPE	SCH.	SCHEDULE
		S.D.	SEE DETAIL
EL, ELEV.	ELEVATION	SHT	SHEET
EOC	EDGE OF CONCRETE	STA	STATION
EOP	EDGE OF PAVEMENT	STD.	STANDARD
ESMT	EASEMENT	STM	STORM
EX.	EXISTING	SVC.	SERVICE
FC	FACE OF CURB	TBA	TO BE ABANDONED
FES	FLARED END SECTION	TBR	TO BE REMOVED
FH	FIRE HYDRANT	T.O.P.	TOP OF PIPE
FL	FLOWLINE	TYP.	TYPICAL
FLG	FLANGE		
		U.N.O.	UNLESS NOTED OTHERWISE
GB	GRADE BREAK		
GV	GATE VALVE	VC	VERTICAL CURVE
		VERT.	VERTICAL
HDPE	HIGH DENSITY POLYETHYLENE		
HP	HIGH POINT	WTR	WATER
HORIZ.	HORIZONTAL		
HYD	HYDRANT		
I.D.	INSIDE DIAMETER		
LT	LEFT		
LF	LINEAR FEET		
LP	LOW POINT		
MAX.	MAXIMUM		
MH	MANHOLE		
MIN.	MINIMUM		
MJ	MECHANICAL JOINT		
NOM.	NOMINAL		
NTS	NOT TO SCALE		
O.C.	ON CENTER		
O.C.E.W.	ON CENTER EACH WAY		
O.D.	OUTSIDE DIAMETER		



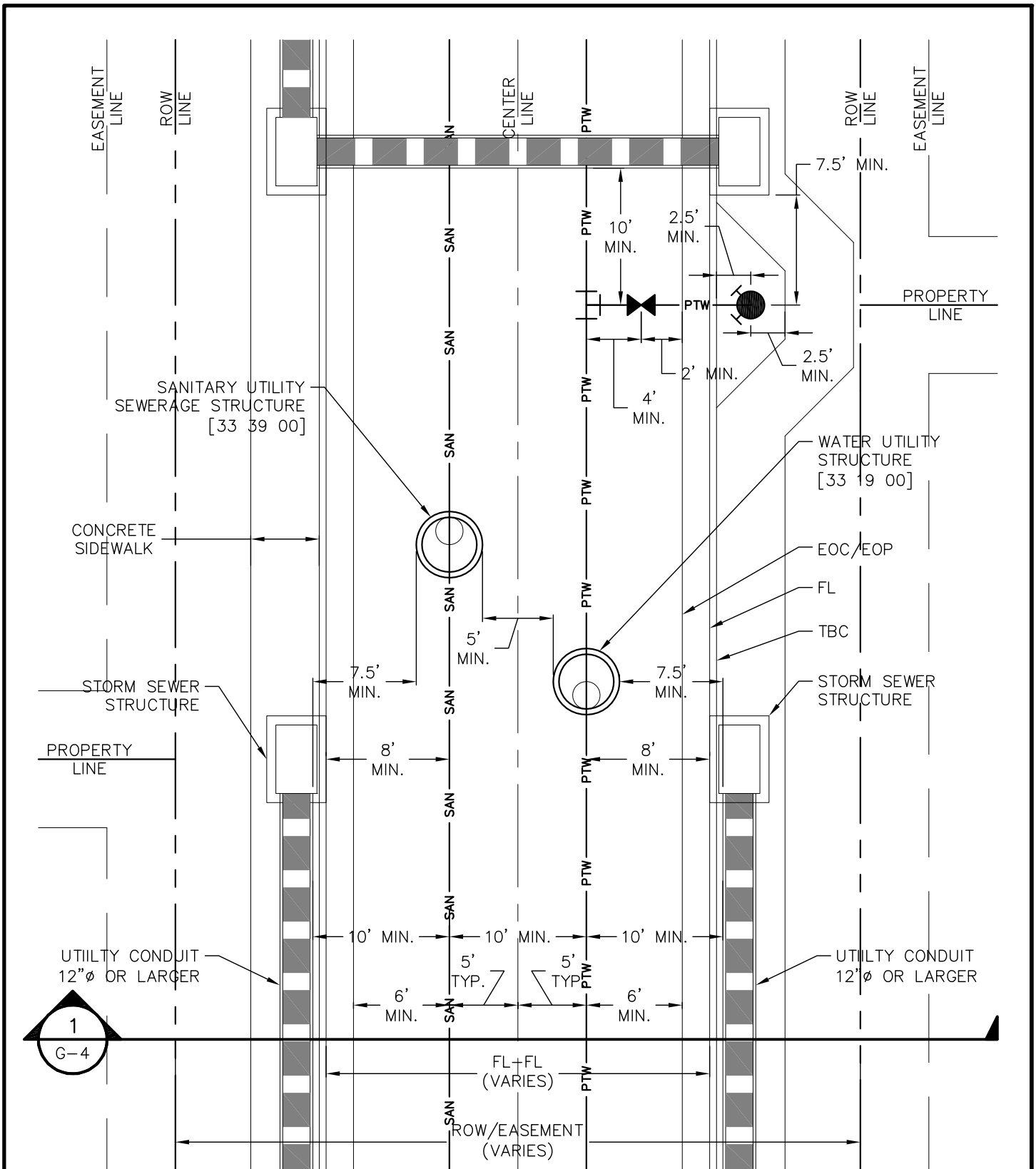

1 TYPICAL UTILITIES LAYOUT (PLAN)
1"=10'

 WOODMOOR WATER & SANITATION DISTRICT NO. 1	TYPICAL UTILITIES LAYOUT (PLAN)	G-3
	GENERAL	-
	<small>THIS CONSTRUCTION DETAIL SHOWS GENERAL CONFORMANCE TO SYSTEM SPECIFICATIONS AND MAY NEED TO BE ADJUSTED FOR SPECIFIC APPLICATIONS.</small>	

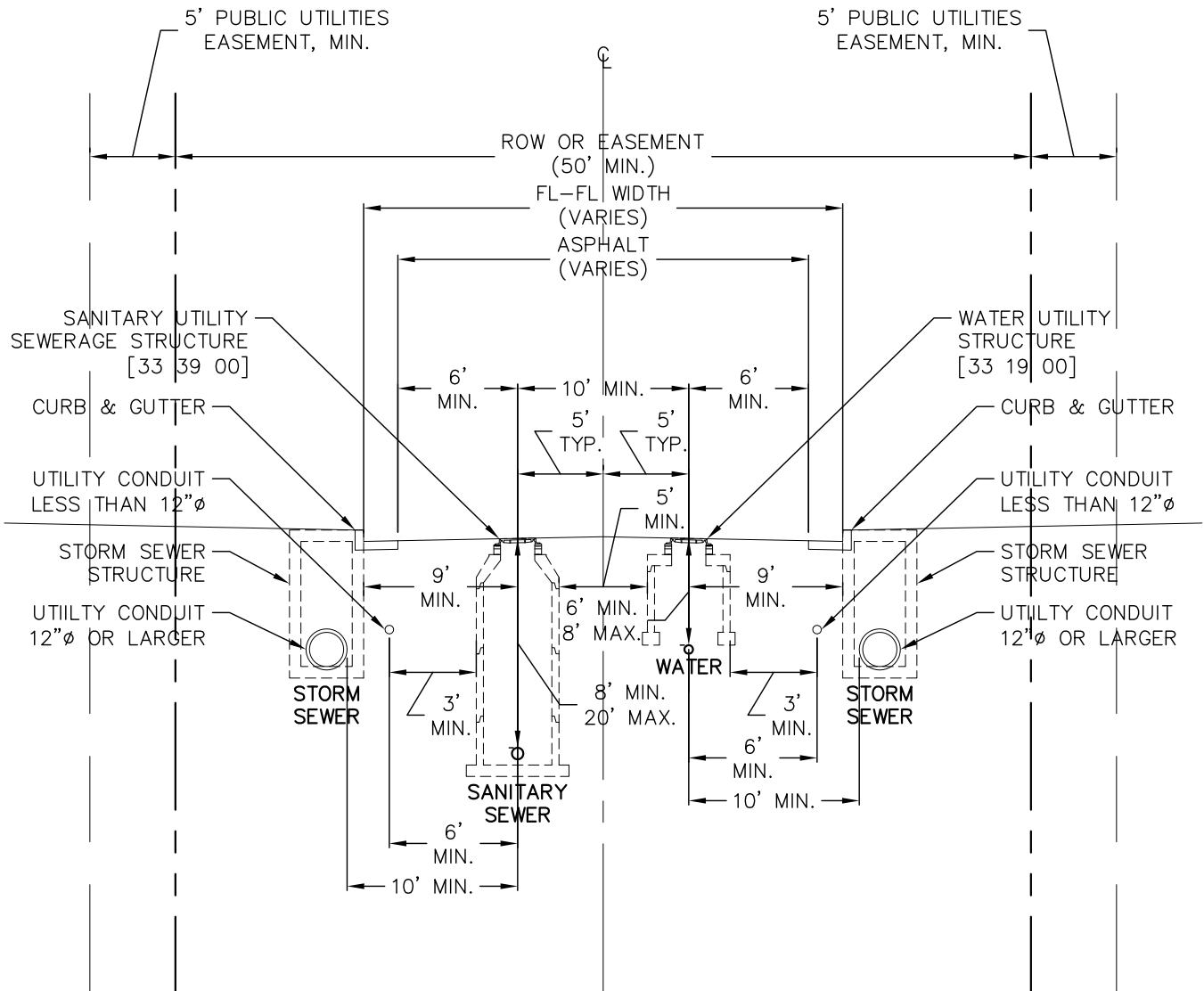
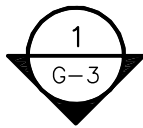

1 TYPICAL UTILITIES LAYOUT (SECTION)
1"=10'

	TYPICAL UTILITIES LAYOUT (SECTION)	G-4
	GENERAL	-
	THIS CONSTRUCTION DETAIL SHOWS GENERAL CONFORMANCE TO SYSTEM SPECIFICATIONS AND MAY NEED TO BE ADJUSTED FOR SPECIFIC APPLICATIONS.	MAY 13, 2014

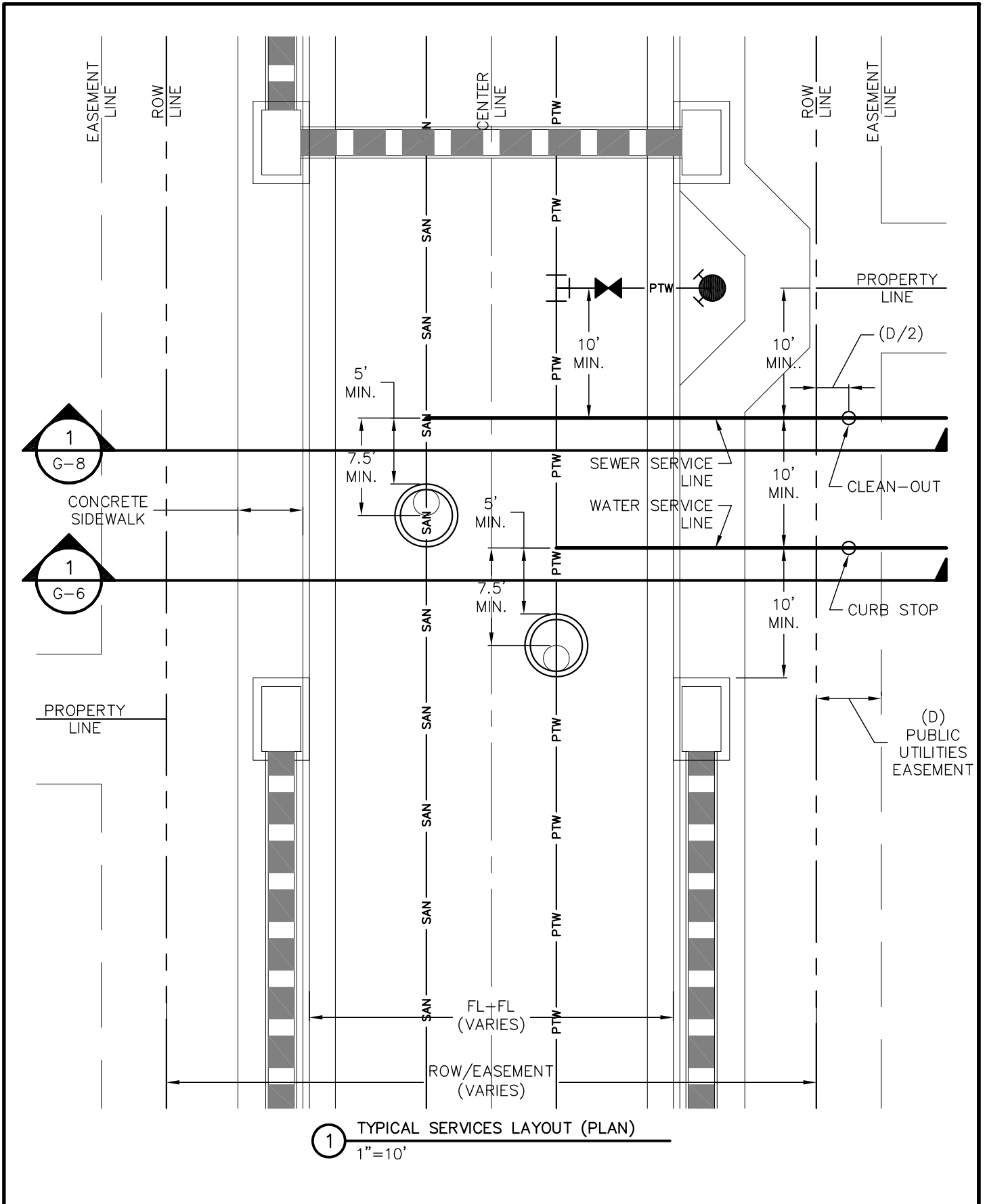

 <p>WOODMOOR WATER & SANITATION DISTRICT NO. 1</p>	TYPICAL SERVICES LAYOUT (PLAN)	G-5
	GENERAL	-
	THIS CONSTRUCTION DETAIL SHOWS GENERAL CONFORMANCE TO SYSTEM SPECIFICATIONS AND MAY NEED TO BE ADJUSTED FOR SPECIFIC APPLICATIONS.	MAY 13, 2014

REFER TO WATER & SEWER SERVICE LINE EQUIPMENT SPECIFICATIONS FOR SUPPLEMENTAL INFORMATION
(APP C OF THE SYSTEM SPECIFICATIONS)

GENERAL NOTES:

- PROVIDE METAL T-POST AT CURB STOP WHEN CONSTRUCTION OF STUB-OUT TO LOT IS COMPLETE. T-POST MAY BE REMOVED AFTER CONNECTION TO SERVICE STUB.
- SERVICE LINE MAY BE TYPE K COPPER OR APPROVED HDPE TUBING (33 11 00). ALL HDPE SERVICE LINES REQUIRE STIFFENING INSERTS AT ALL CONNECTION POINTS OF FITTINGS.

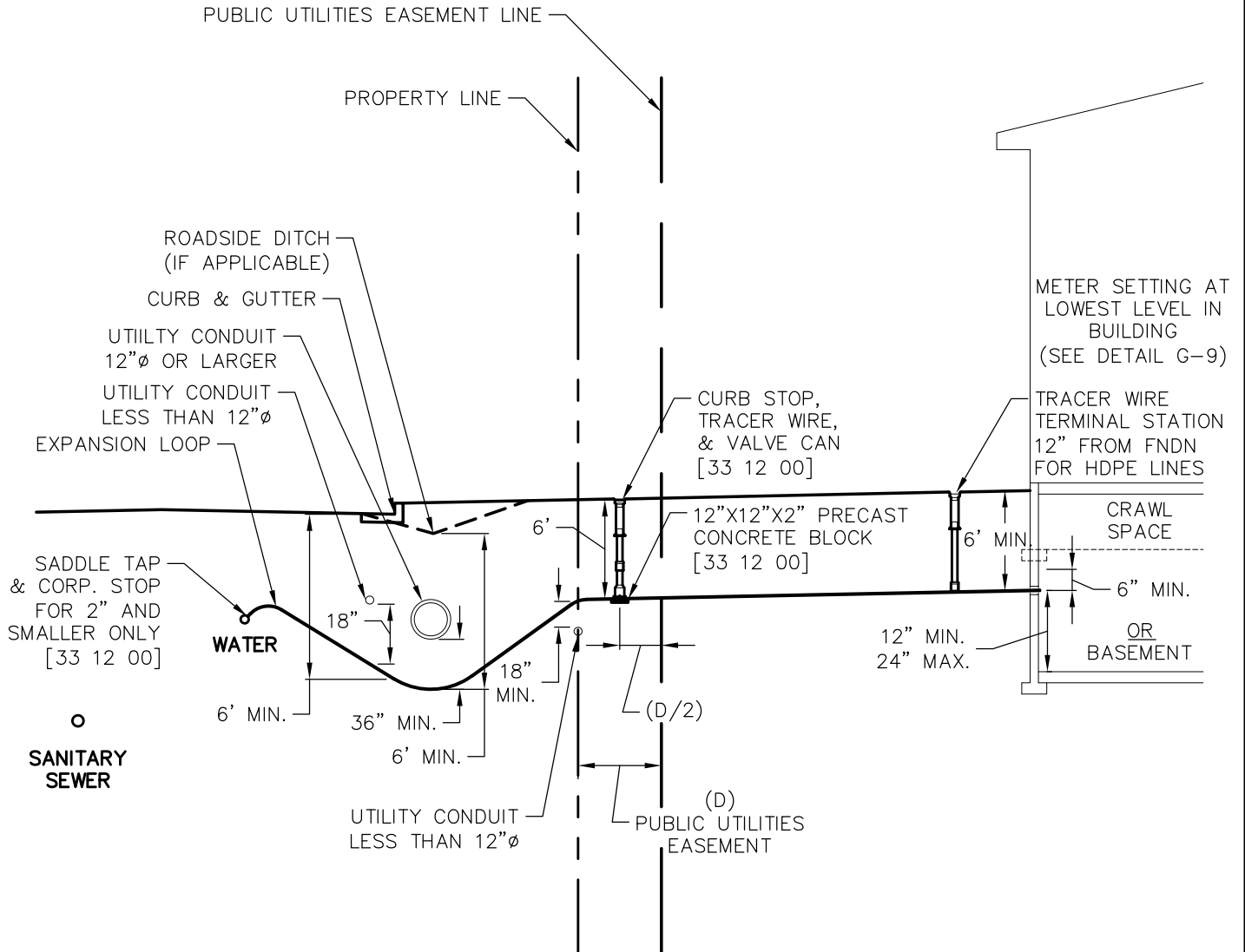

① WATER SERVICE (3/4" TO 2")
1"=10'

	WATER SERVICE (3/4" TO 2")	G-6
	GENERAL	-
	<small>THIS CONSTRUCTION DETAIL SHOWS GENERAL CONFORMANCE TO SYSTEM SPECIFICATIONS AND MAY NEED TO BE ADJUSTED FOR SPECIFIC APPLICATIONS.</small>	

REFER TO WATER & SEWER SERVICE LINE EQUIPMENT SPECIFICATIONS FOR SUPPLEMENTAL INFORMATION
(APP C OF THE SYSTEM SPECIFICATIONS)

GENERAL NOTES:

- MECHANICAL JOINT RESTRAINTS REQUIRED ON ALL FITTINGS.

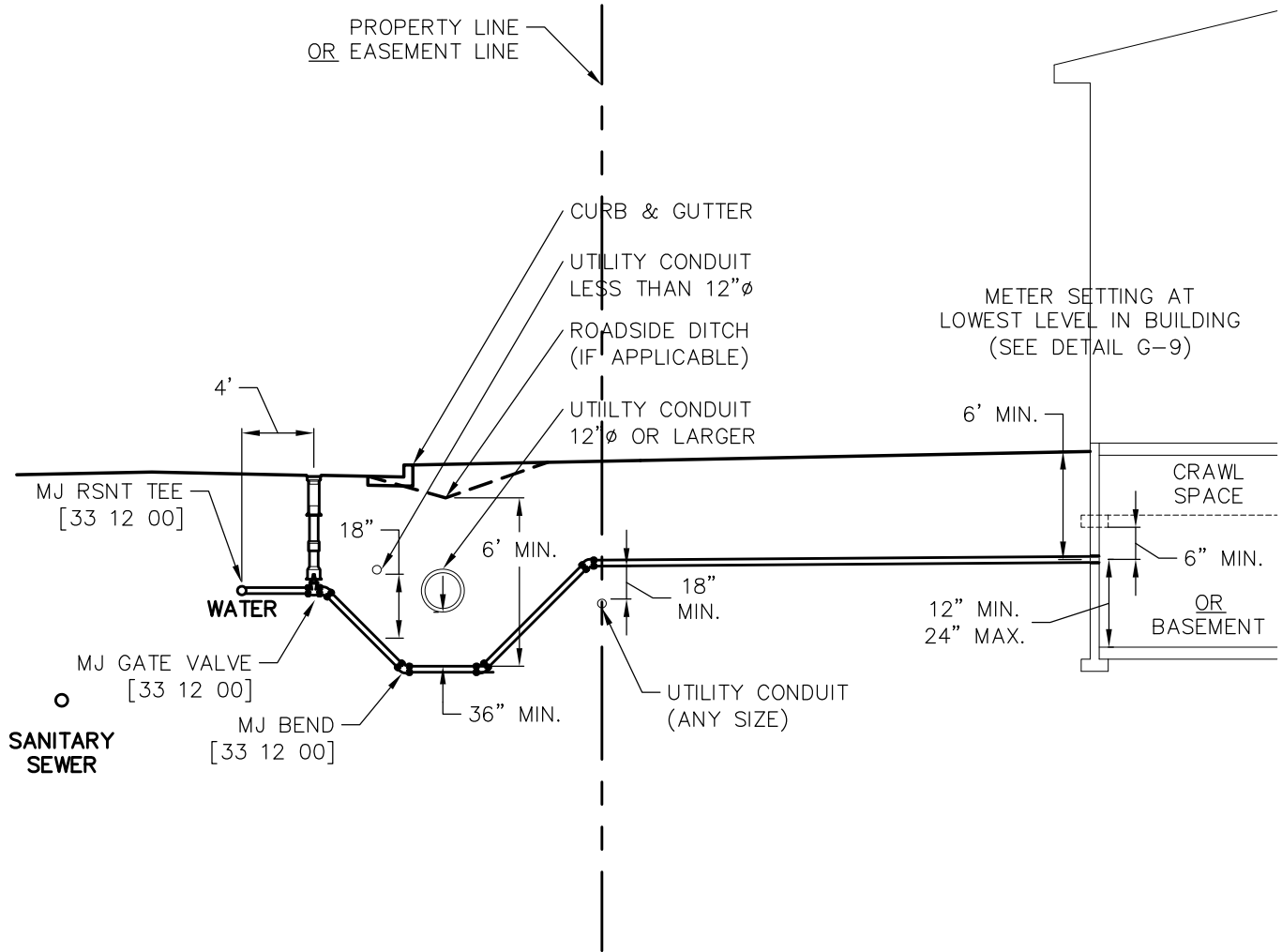

① WATER SERVICE (2-1/2" TO 6")
1"=10'

	WATER SERVICE (2-1/2" TO 6")	G-7
	GENERAL	-
	THIS CONSTRUCTION DETAIL SHOWS GENERAL CONFORMANCE TO SYSTEM SPECIFICATIONS AND MAY NEED TO BE ADJUSTED FOR SPECIFIC APPLICATIONS.	JAN 1, 2023

REFER TO WATER & SEWER SERVICE LINE EQUIPMENT SPECIFICATIONS FOR SUPPLEMENTAL INFORMATION
(APP C OF THE SYSTEM SPECIFICATIONS)

GENERAL NOTES:

- PROVIDE METAL T-POST AT CURB STOP WHEN CONSTRUCTION OF STUB-OUT TO LOT IS COMPLETE. T-POST MAY BE REMOVED AFTER CONNECTION TO SERVICE STUB.
- INTERMEDIATE CLEAN-OUT ASSEMBLIES REQUIRED AT 100' INTERVALS (FOR UNI-DIRECTIONAL) OR 200' INTERVALS (FOR BI-DIRECTIONAL) BETWEEN PROPERTY LINE CLEAN-OUT AND BUILDING CLEAN-OUT..

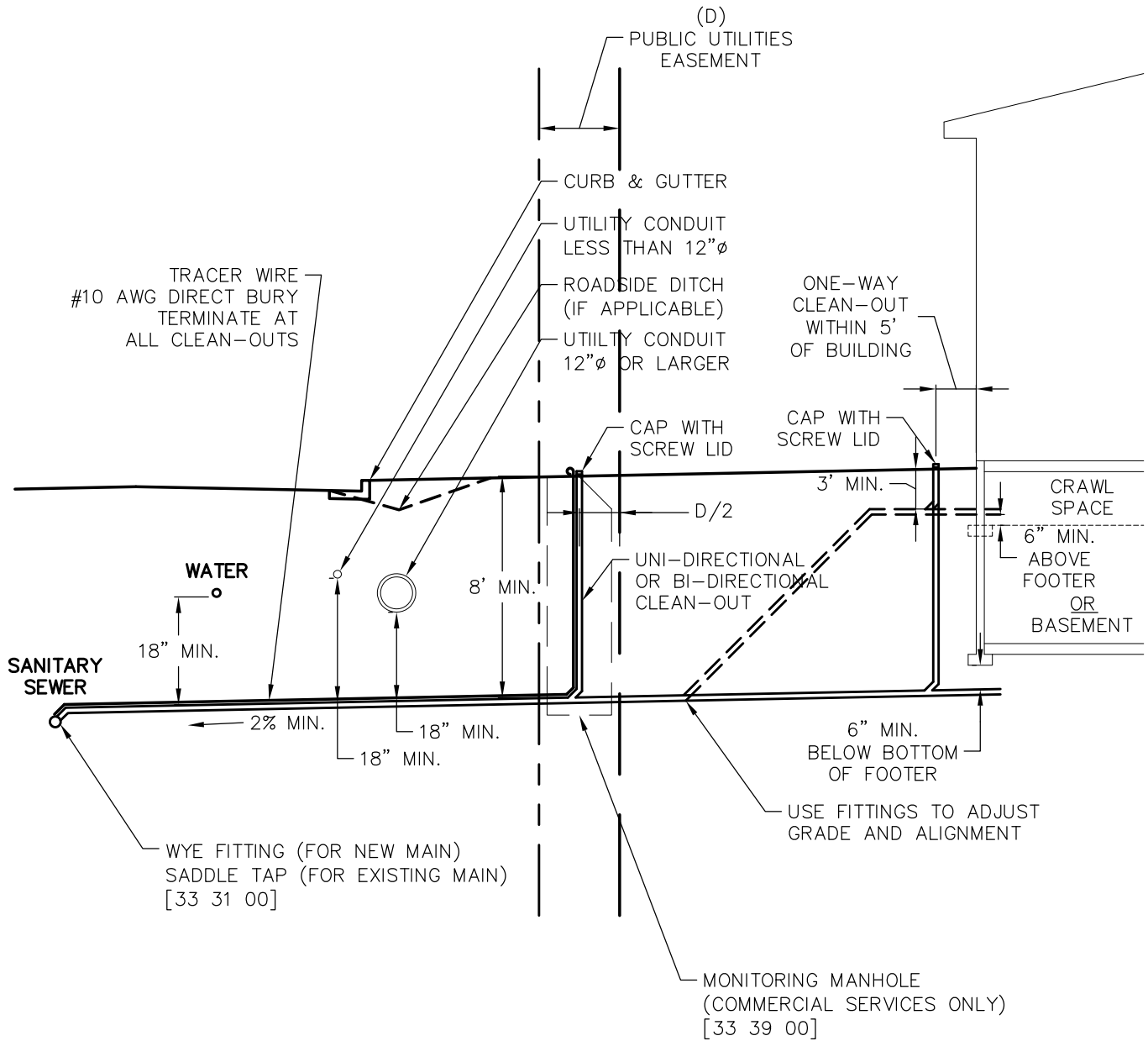

1 TYPICAL SEWER SERVICE (SECTION)
1"=10'

	TYPICAL SEWER SERVICE (SECTION)	G-8
	GENERAL	-
	THIS CONSTRUCTION DETAIL SHOWS GENERAL CONFORMANCE TO SYSTEM SPECIFICATIONS AND MAY NEED TO BE ADJUSTED FOR SPECIFIC APPLICATIONS.	JAN 1, 2023

REFER TO WATER & SEWER SERVICE LINE EQUIPMENT SPECIFICATIONS FOR SUPPLEMENTAL INFORMATION
(APPENDIX C OF THE SYSTEM SPECIFICATIONS)

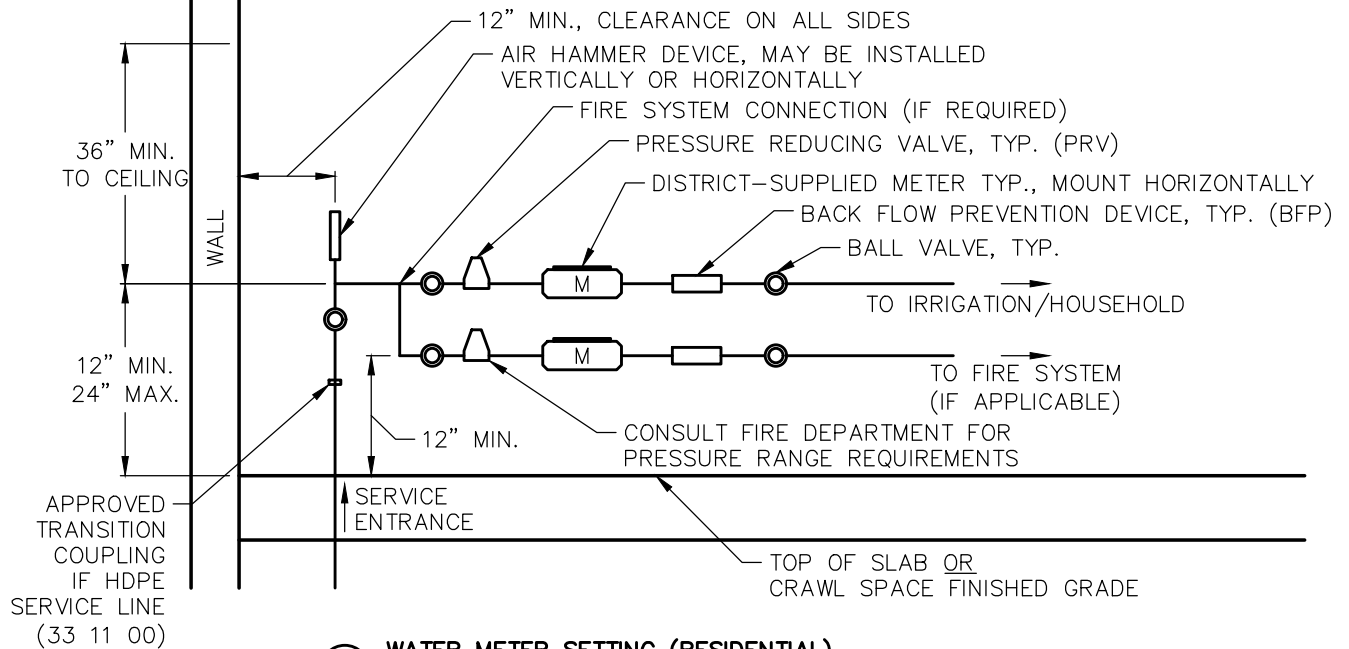

1 WATER METER SETTING (RESIDENTIAL)
NOT TO SCALE

NOTE: FOR ALL HDPE SERVICE TUBING, INSTALL TRANSITION COUPLINGS AND UNISTRUT PIPE SUPPORTS ON COPPER METER ASSEMBLY (33 11 00)

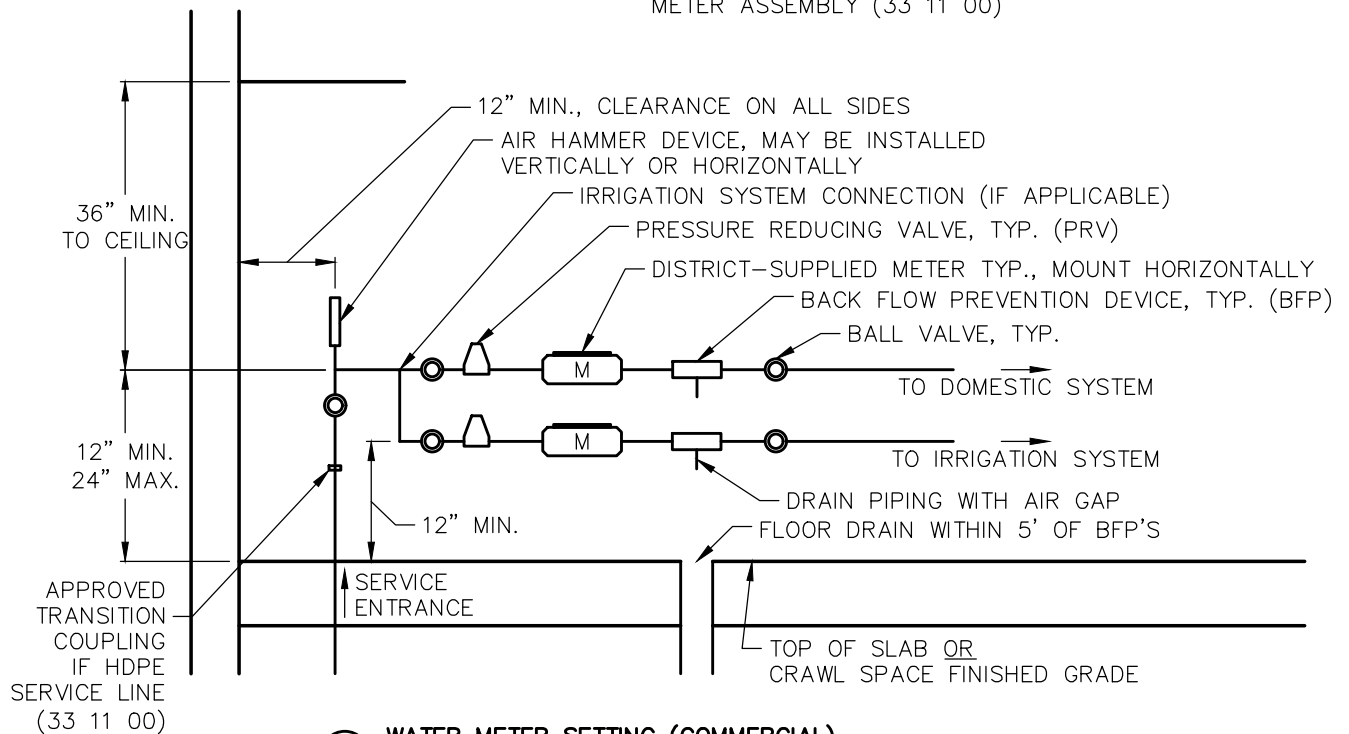

1 WATER METER SETTING (COMMERCIAL)
NOT TO SCALE



WATER METER SETTING DETAIL

G-9

GENERAL

-

THIS CONSTRUCTION DETAIL SHOWS GENERAL CONFORMANCE TO SYSTEM SPECIFICATIONS AND MAY NEED TO BE ADJUSTED FOR SPECIFIC APPLICATIONS.

JUNE 6, 2023

REFER TO WATER & SEWER SERVICE LINE EQUIPMENT SPECIFICATIONS FOR SUPPLEMENTAL INFORMATION
(APP C OF THE SYSTEM SPECIFICATIONS)

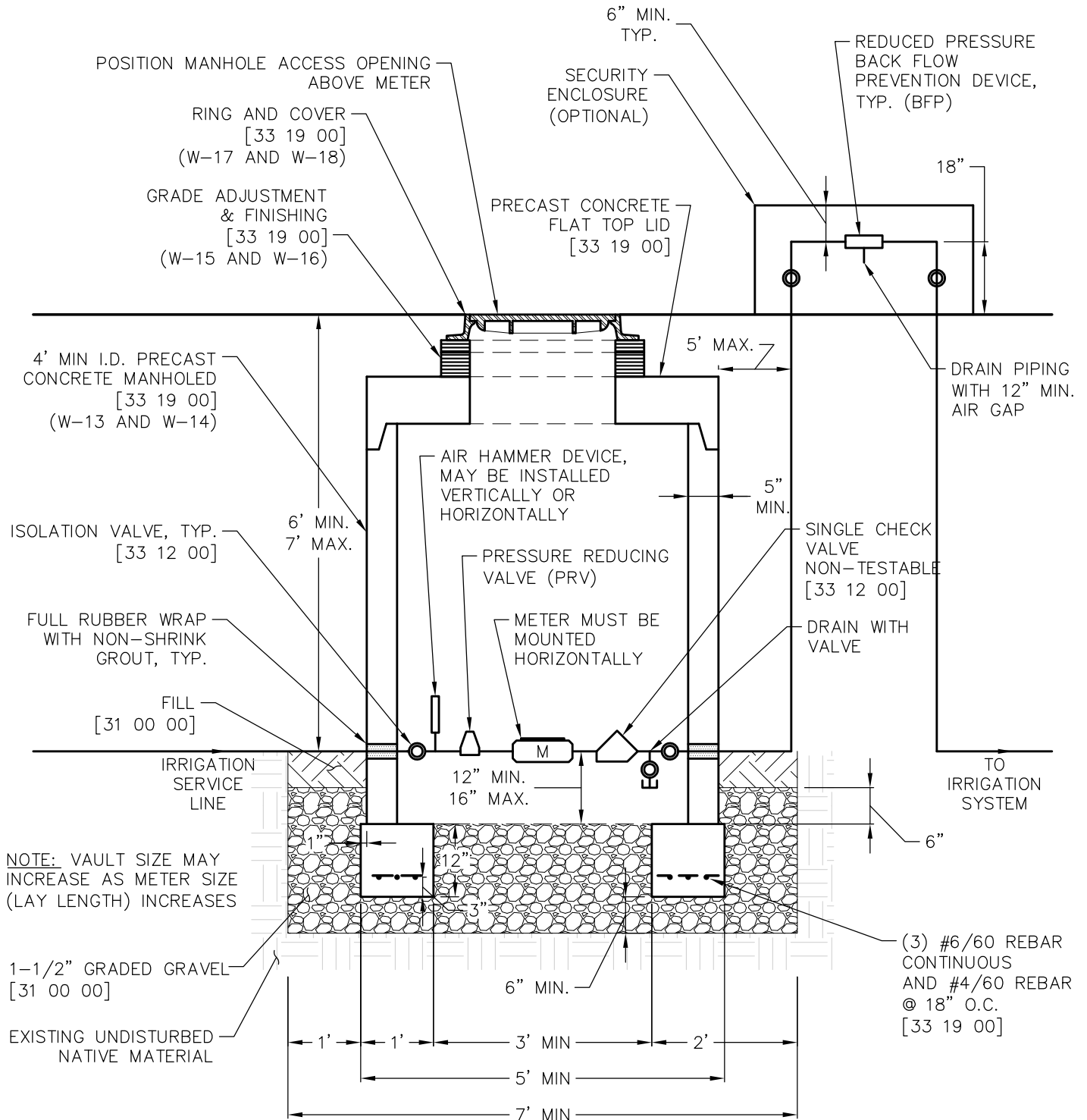

① METER PIT VAULT (SECTION)
1"=2'



IRRIGATION ONLY METER PIT
(POTABLE WATER SYSTEM)

THIS CONSTRUCTION DETAIL SHOWS GENERAL CONFORMANCE TO SYSTEM SPECIFICATIONS AND MAY NEED TO BE ADJUSTED FOR SPECIFIC APPLICATIONS.

G-10
-
SEPTEMBER 1, 2022

REFER TO WATER & SEWER SERVICE LINE EQUIPMENT SPECIFICATIONS FOR SUPPLEMENTAL INFORMATION
(APP C OF THE SYSTEM SPECIFICATIONS)

GENERAL NOTES:

- PROVIDE METAL T-POST AT CURB STOP WHEN CONSTRUCTION OF STUB-OUT TO LOT IS COMPLETE.
T-POST MAY BE REMOVED AFTER CONNECTION TO SERVICE STUB.

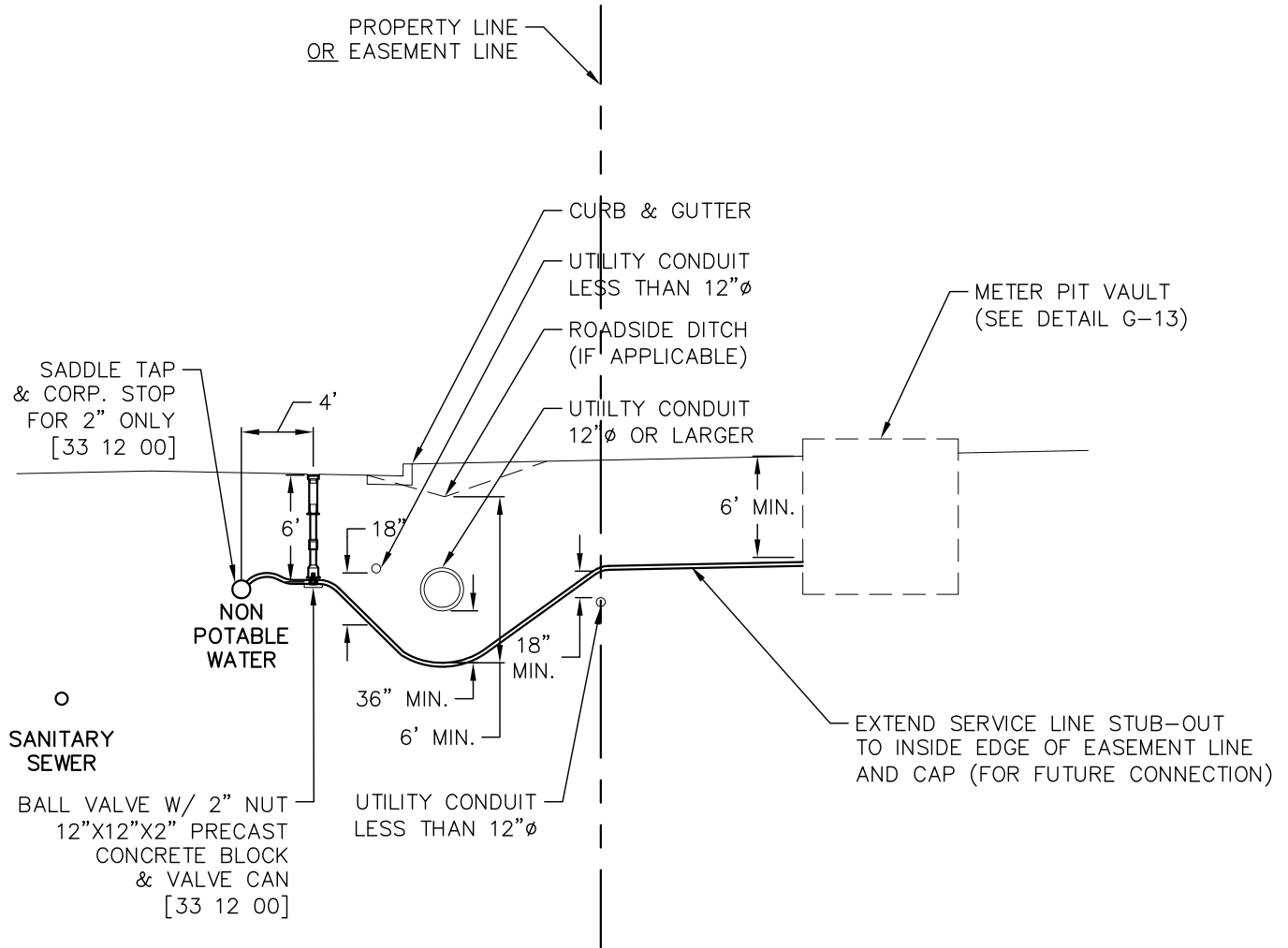

1 WATER SERVICE (2")
1"=10'

 <p>WOODMOOR WATER & SANITATION DISTRICT NO. 1</p>	NON-POTABLE WATER SERVICE LINE	G-11
	2"	-
	<p>THIS CONSTRUCTION DETAIL SHOWS GENERAL CONFORMANCE TO SYSTEM SPECIFICATIONS AND MAY NEED TO BE ADJUSTED FOR SPECIFIC APPLICATIONS.</p> <p>MAY 13, 2014</p>	

REFER TO WATER & SEWER SERVICE LINE EQUIPMENT SPECIFICATIONS FOR SUPPLEMENTAL INFORMATION
(APP C OF THE SYSTEM SPECIFICATIONS)

GENERAL NOTES:

– MECHANICAL JOINT RESTRAINTS REQUIRED ON ALL FITTINGS.

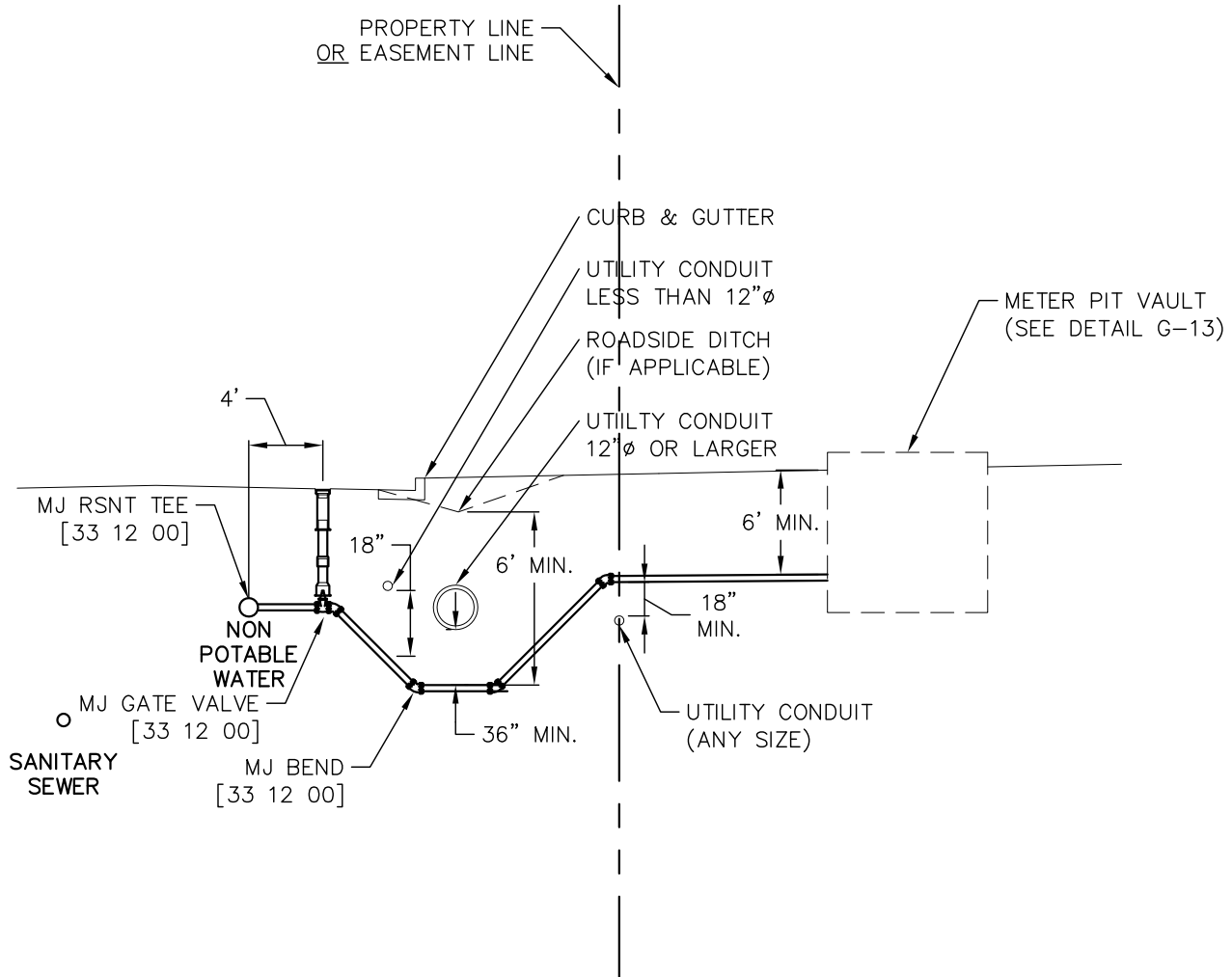

① WATER SERVICE (2-1/2" TO 6")
1"=10'

 WOODMOOR WATER & SANITATION DISTRICT NO. 1	NON-POTABLE WATER SERVICE LINE	G-12
	2-1/2" TO 6"	-
	<small>THIS CONSTRUCTION DETAIL SHOWS GENERAL CONFORMANCE TO SYSTEM SPECIFICATIONS AND MAY NEED TO BE ADJUSTED FOR SPECIFIC APPLICATIONS.</small>	
		MAY 13, 2014

REFER TO WATER & SEWER SERVICE LINE EQUIPMENT SPECIFICATIONS FOR SUPPLEMENTAL INFORMATION
(APP C OF THE SYSTEM SPECIFICATIONS)

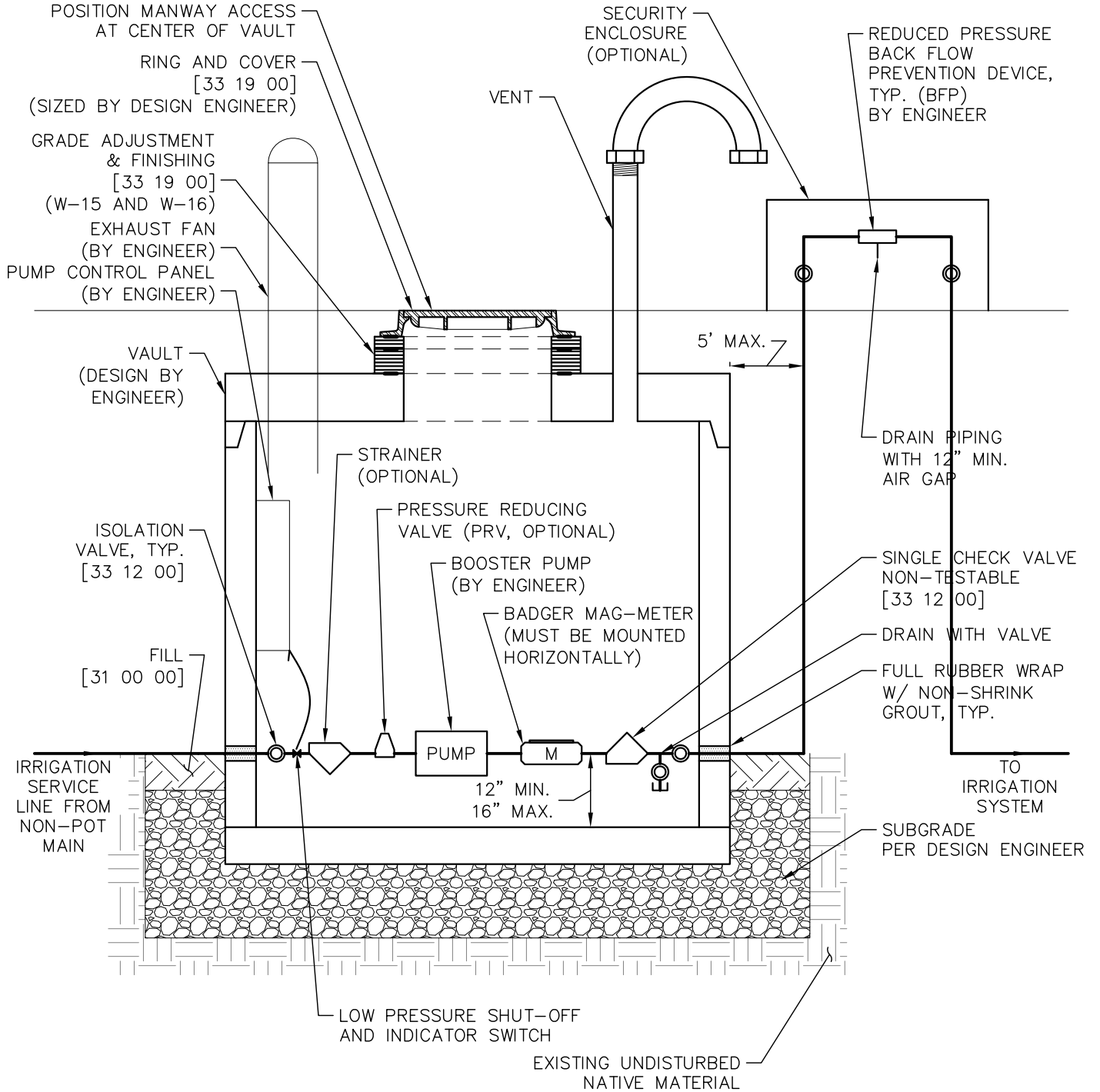

① PUMP STATION (TYPICAL SUBGRADE INSTALLATION)
1" = 2'

NOTE: ABOVE GROUND ELECTRICAL AND/OR PUMP STATION CONFIGURATIONS MAY ALSO BE PROPOSED.

	IRRIGATION ONLY METER PIT	G-13
	(NON-POTABLE WATER SYSTEM)	-
	THIS CONSTRUCTION DETAIL SHOWS GENERAL CONFORMANCE TO SYSTEM SPECIFICATIONS AND MAY NEED TO BE ADJUSTED FOR SPECIFIC APPLICATIONS.	MAY 13, 2014

VEGETATED SURFACE

PAVED SURFACE

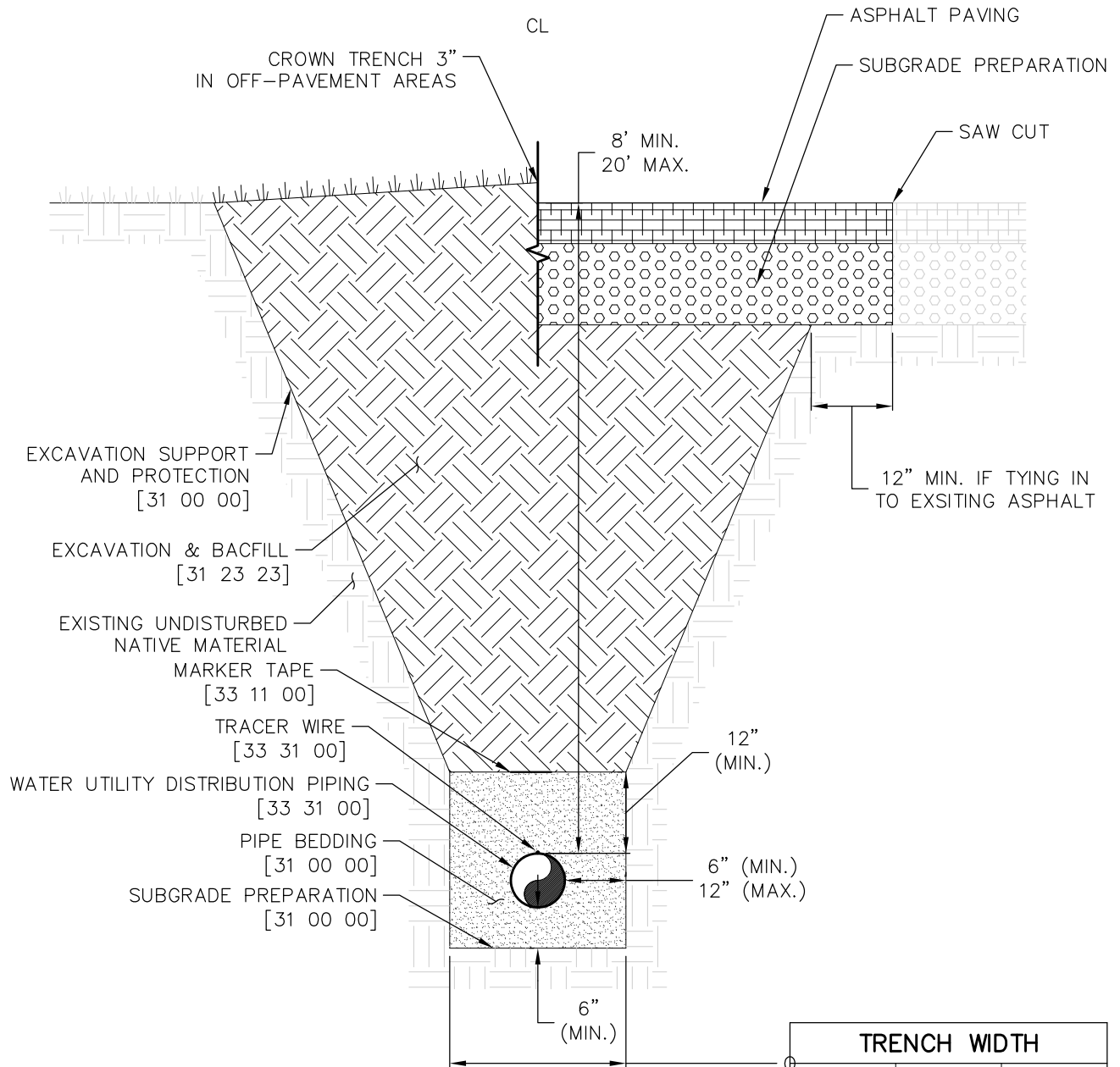

① TYPICAL TRENCH SECTION
1"=2'

TRENCH WIDTH		
PIPE DIAMETER	MINIMUM WIDTH	MAXIMUM WIDTH
4"	1'-4"	2'-4"
6"	1'-6"	2'-6"
8"	1'-8"	2'-8"
10"	1'-10"	2'-10"
12"	2'-0"	3'-0"
14"	2'-2"	3'-2"



WOODMOOR
WATER & SANITATION DISTRICT NO. 1

TYPICAL SEWER TRENCH SECTION
SANITARY UTILITY SEWERAGE PIPING

S-1

33 31 00

THIS CONSTRUCTION DETAIL SHOWS GENERAL CONFORMANCE TO SYSTEM SPECIFICATIONS AND MAY NEED TO BE ADJUSTED FOR SPECIFIC APPLICATIONS.

JAN 1, 2023

VEGETATED SURFACE

PAVED SURFACE

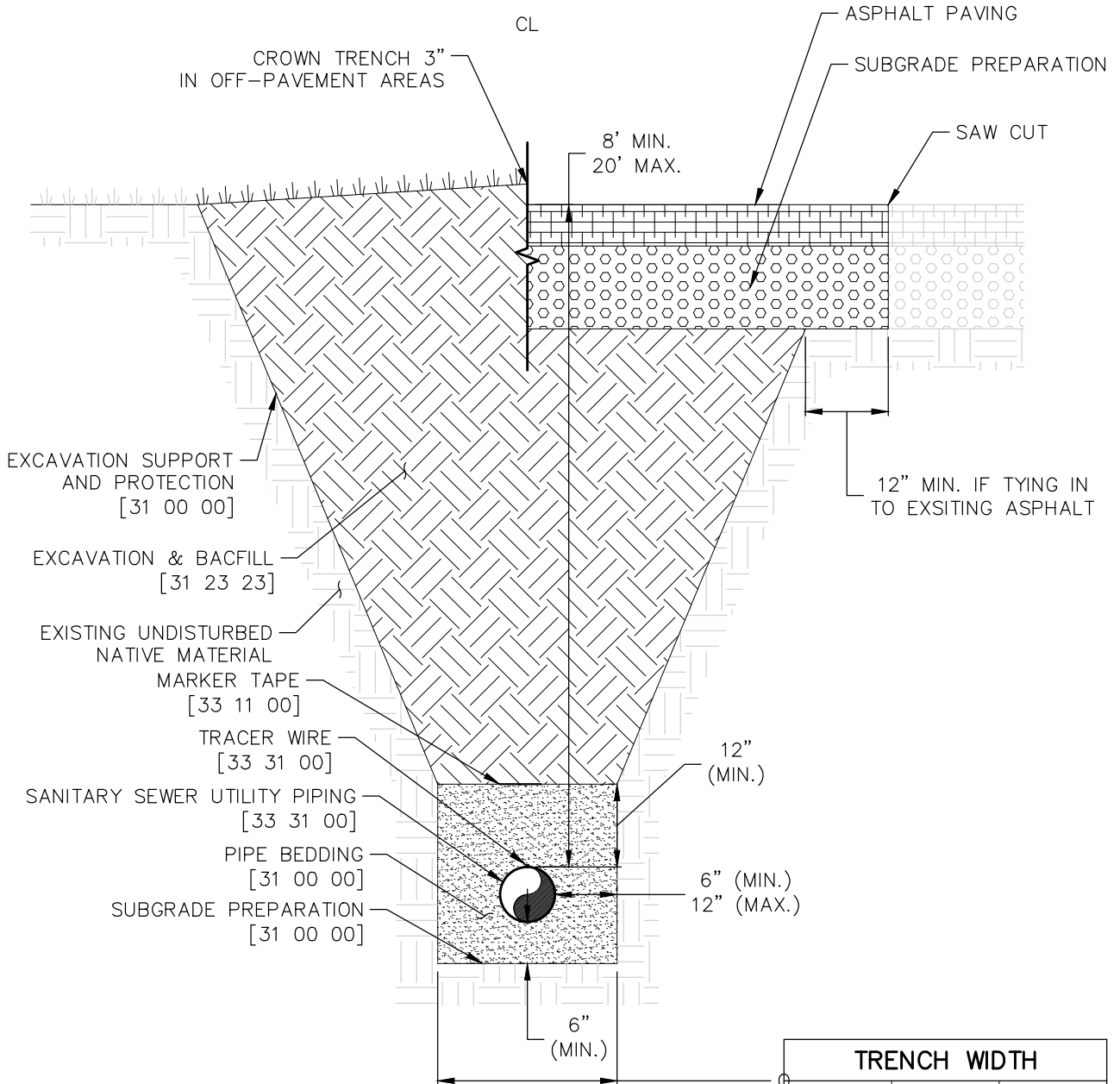

EXCAVATION SUPPORT AND PROTECTION [31 00 00]

EXCAVATION & BACFILL [31 23 23]

EXISTING UNDISTURBED NATIVE MATERIAL

MARKER TAPE [33 11 00]

TRACER WIRE [33 31 00]

SANITARY SEWER UTILITY PIPING [33 31 00]

PIPE BEDDING [31 00 00]

SUBGRADE PREPARATION [31 00 00]

12" (MIN.)

6" (MIN.)
12" (MAX.)

6" (MIN.)

TRENCH WIDTH		
PIPE DIAMETER	MINIMUM WIDTH	MAXIMUM WIDTH
4"	1'-4"	2'-4"
6"	1'-6"	2'-6"
8"	1'-8"	2'-8"
10"	1'-10"	2'-10"
12"	2'-0"	3'-0"
14"	2'-2"	3'-2"

1 TYPICAL TRENCH SECTION
1"=2'

SEE DRAWING S-2 FOR TYPICAL ECCENTRIC CONE MANHOLE

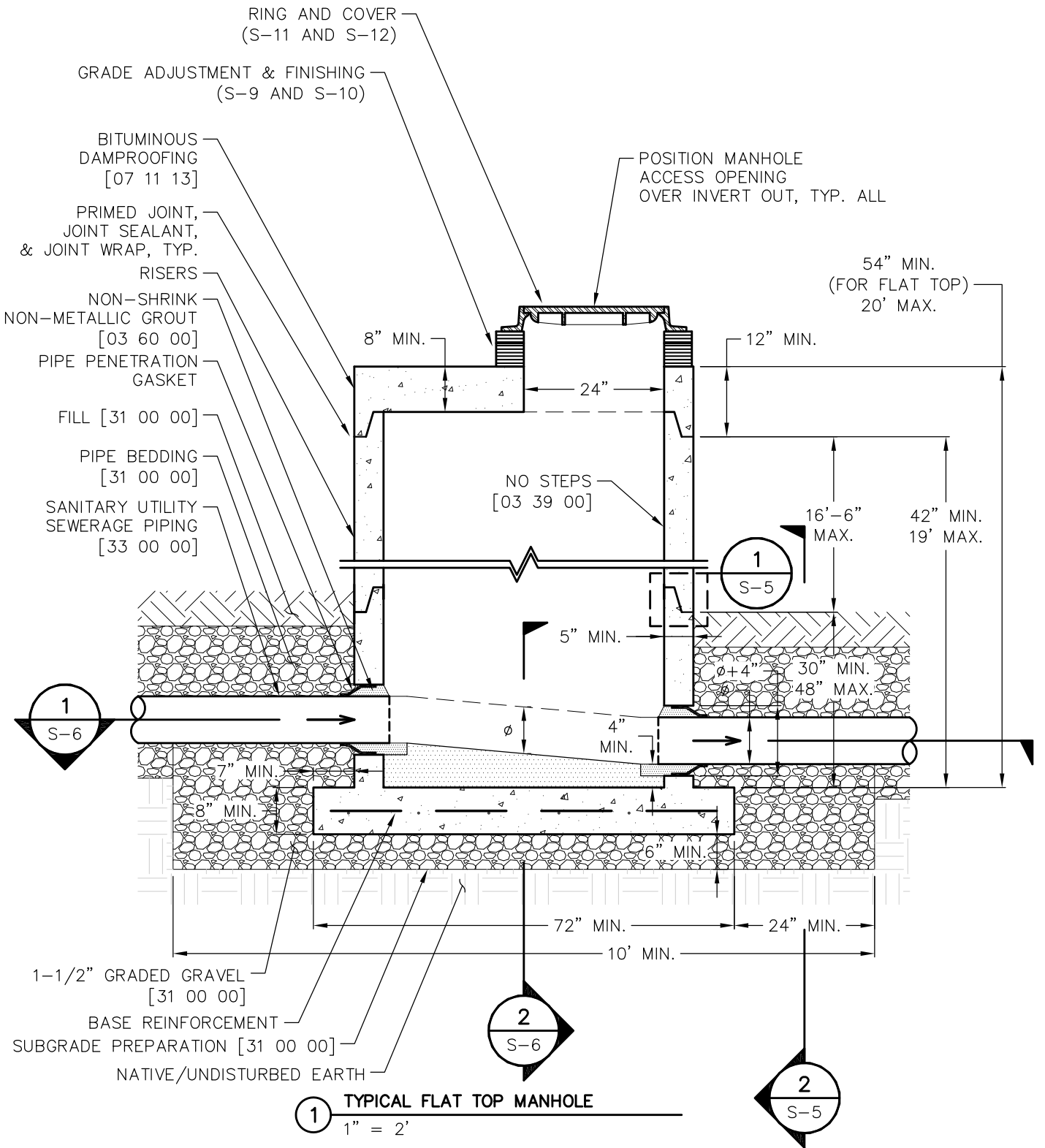

TYPICAL FLAT TOP MANHOLE	S-3
SANITARY UTILITY SEWERAGE STRUCTURES	33 39 00
THIS CONSTRUCTION DETAIL SHOWS GENERAL CONFORMANCE TO SYSTEM SPECIFICATIONS AND MAY NEED TO BE ADJUSTED FOR SPECIFIC APPLICATIONS.	JAN 1, 2023

- BITUMINOUS DAMPROOFING [07 11 13]
- PRIMED JOINT, JOINT SEALANT, & JOINT WRAP, TYP.
- RISERS
- NON-SHRINK NON-METALLIC GROUT [03 60 00]
- PIPE PENETRATION GASKET
- FILL [31 00 00]
- PIPE BEDDING [31 00 00]
- SANITARY UTILITY SEWERAGE PIPING [33 31 00]

APPLICATION NOTES:
 - DROP MANHOLES CAN BE FINISHED WITH ECCENTRIC CONE OR FLAT TOP, DEPENDING ON APPLICATION (SEE DRAWING S-2 AND S-3)

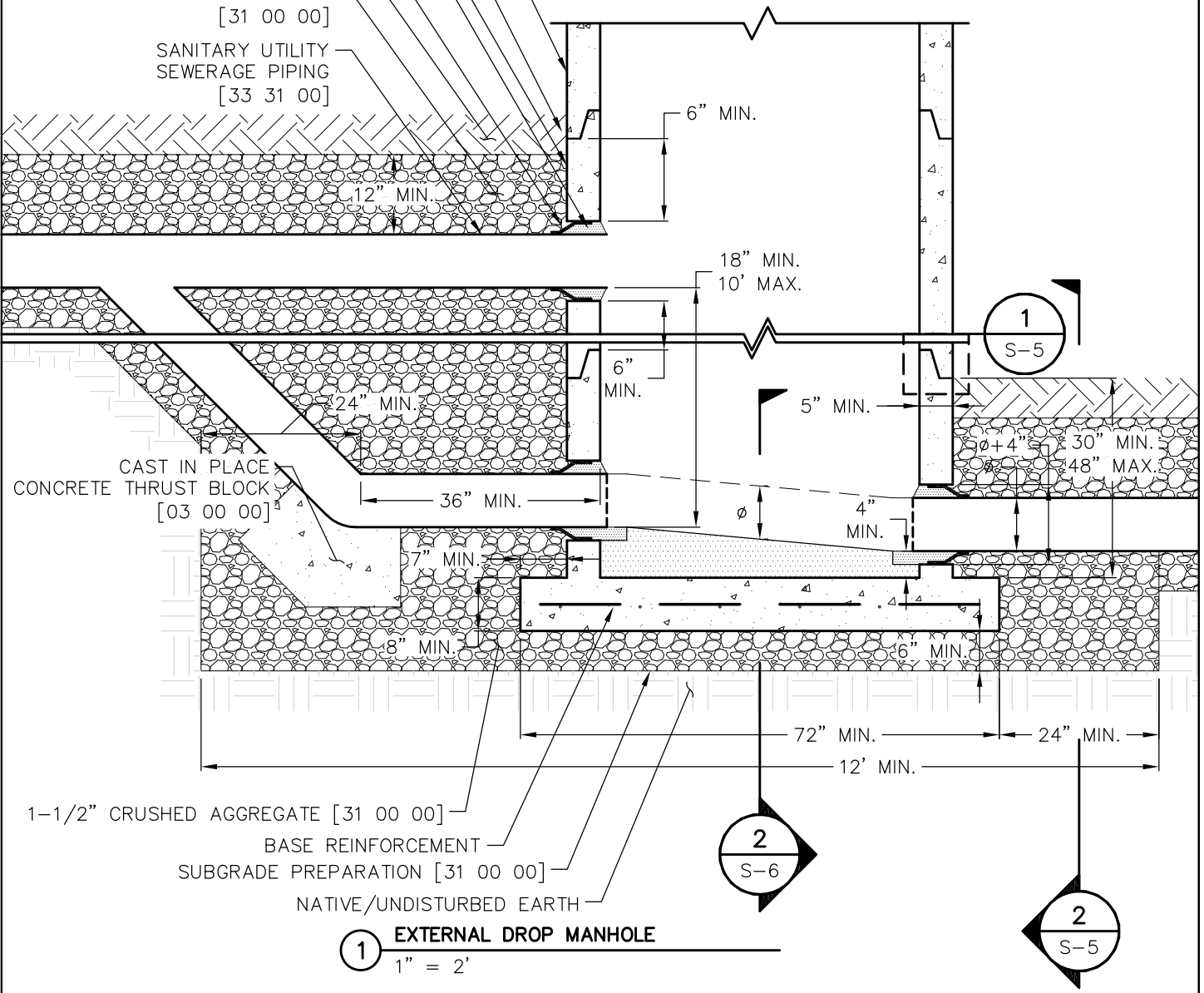

- 1-1/2" CRUSHED AGGREGATE [31 00 00]
- BASE REINFORCEMENT
- SUBGRADE PREPARATION [31 00 00]
- NATIVE/UNDISTURBED EARTH

	TYPICAL DROP MANHOLE	S-4
	SANITARY UTILITY SEWERAGE STRUCTURES	33 39 00
	THIS CONSTRUCTION DETAIL SHOWS GENERAL CONFORMANCE TO SYSTEM SPECIFICATIONS AND MAY NEED TO BE ADJUSTED FOR SPECIFIC APPLICATIONS.	JAN 1, 2023

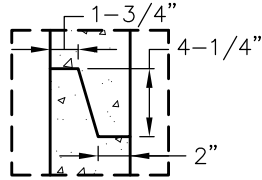

① TONGUE AND GROOVE JOINT
1" = 1'

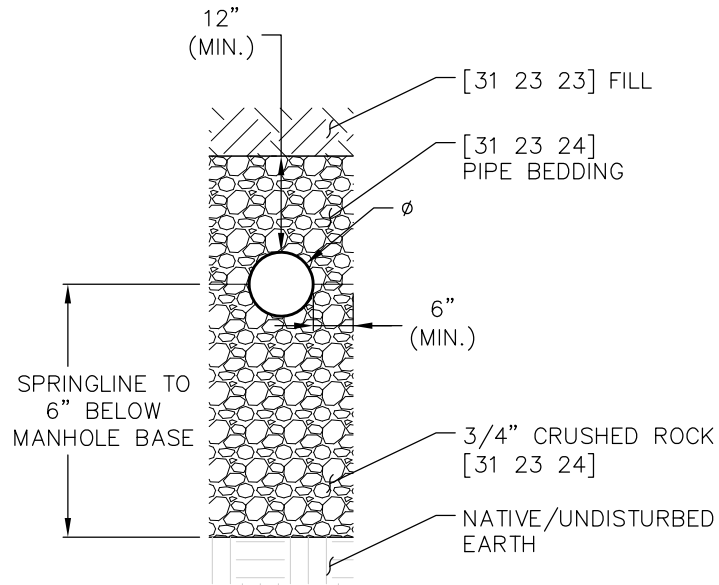

② PIPE BEDDING AT CONNECTION TO MANHOLE
1" = 2'

SEE DRAWING S-7 FOR HIGH-VELOCITY CHANNEL AND BENCH

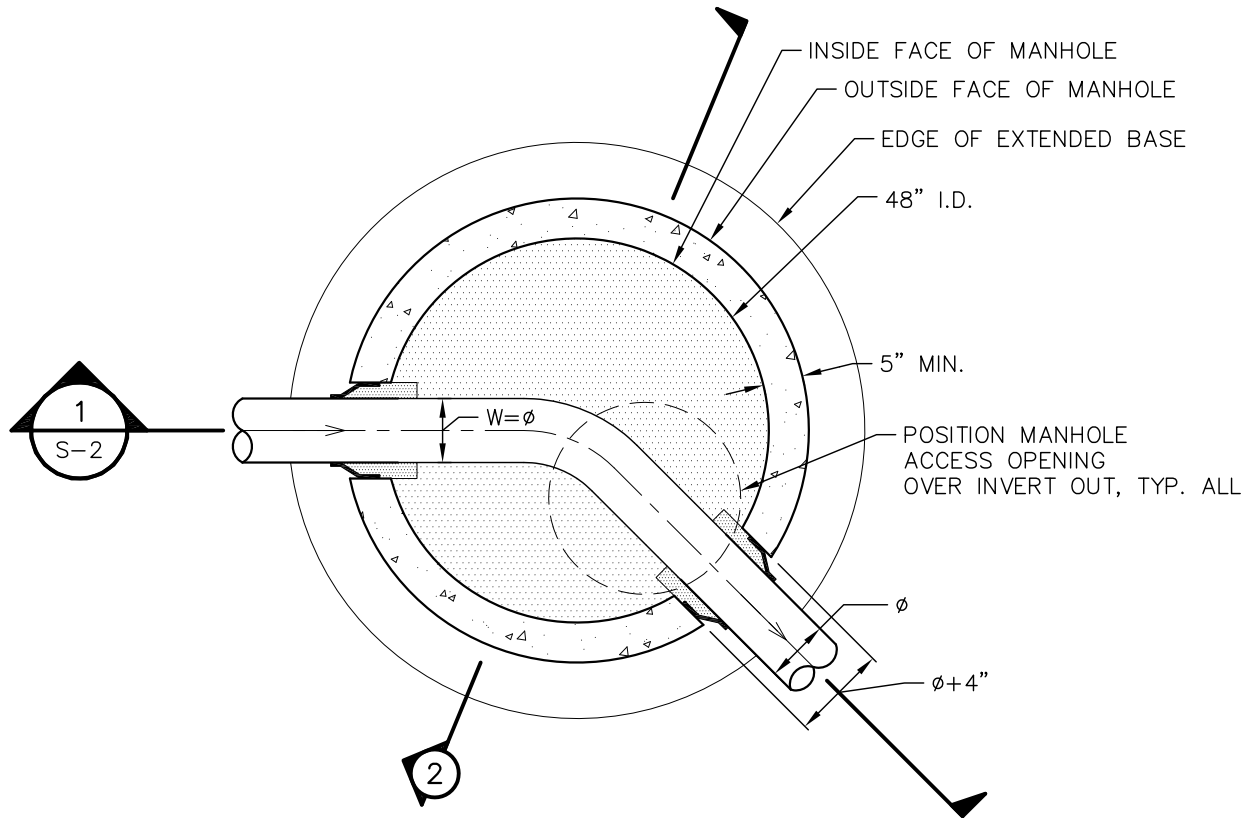

① STANDARD CHANNEL AND BENCH (PLAN)
 1" = 2'

SLOPE BENCH TOWARDS CHANNEL
 AT 1" PER FOOT, TYP.
 ($\frac{1}{2}$ " PER FOOT MIN.,
 1- $\frac{1}{2}$ " PER FOOT MAX.)

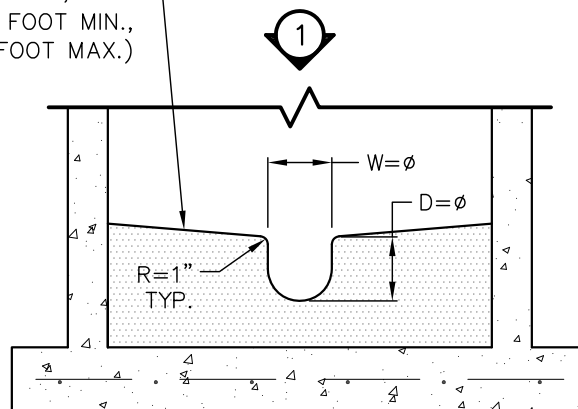

② STANDARD CHANNEL AND BENCH (SECTION)
 1" = 2'



WOODMOOR
 WATER & SANITATION DISTRICT NO. 1

SEWER MANHOLE STANDARD BASE
 SANITARY UTILITY SEWERAGE STRUCTURES

THIS CONSTRUCTION DETAIL SHOWS GENERAL CONFORMANCE TO SYSTEM SPECIFICATIONS AND MAY NEED TO BE ADJUSTED FOR SPECIFIC APPLICATIONS.

S-6

33 39 00

MAY 13, 2014

SEE DRAWING S-6 FOR REGULAR CHANNEL AND BENCH

APPLICATION NOTES:

- USE HIGH VELOCITY BENCH AND CHANNEL WHEN INLET PIPE IS GREATER THAN 12% SLOPE.

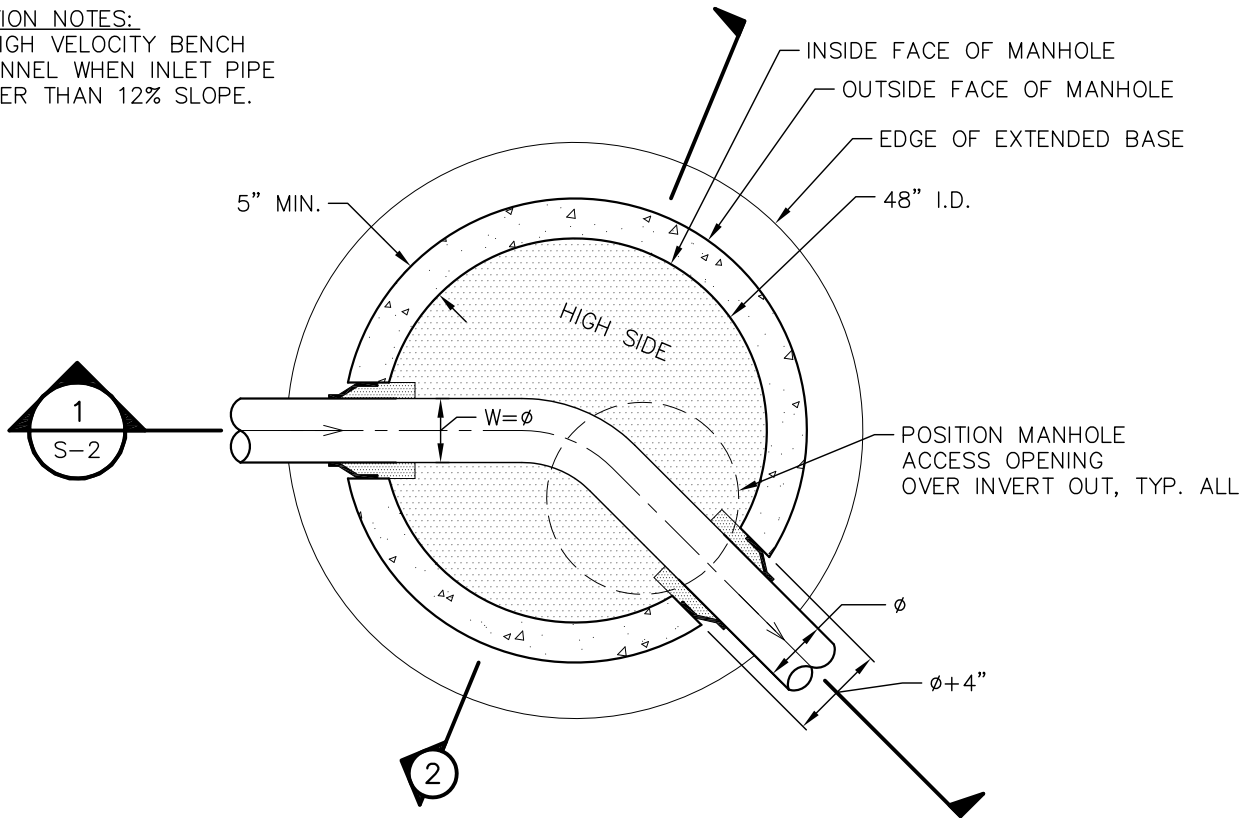

1 MANHOLE BASE PLAN
1" = 2'

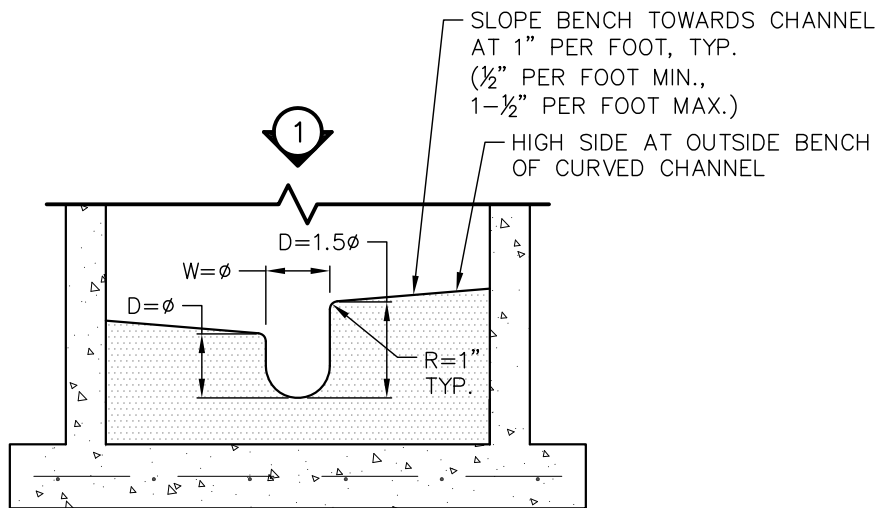

2 HIGH VELOCITY CHANNEL AND BENCH (SECTION)
1" = 2'



WOODMOOR
WATER & SANITATION DISTRICT NO. 1

SEWER MANHOLE HIGH VELOCITY BASE
SANITARY UTILITY SEWERAGE STRUCTURES

S-7

33 39 00

THIS CONSTRUCTION DETAIL SHOWS GENERAL CONFORMANCE TO SYSTEM SPECIFICATIONS AND MAY NEED TO BE ADJUSTED FOR SPECIFIC APPLICATIONS.

MAY 13, 2014

CHANNEL DROP FROM INVERT IN TO INVERT OUT SHALL BE 0.3 FEET.

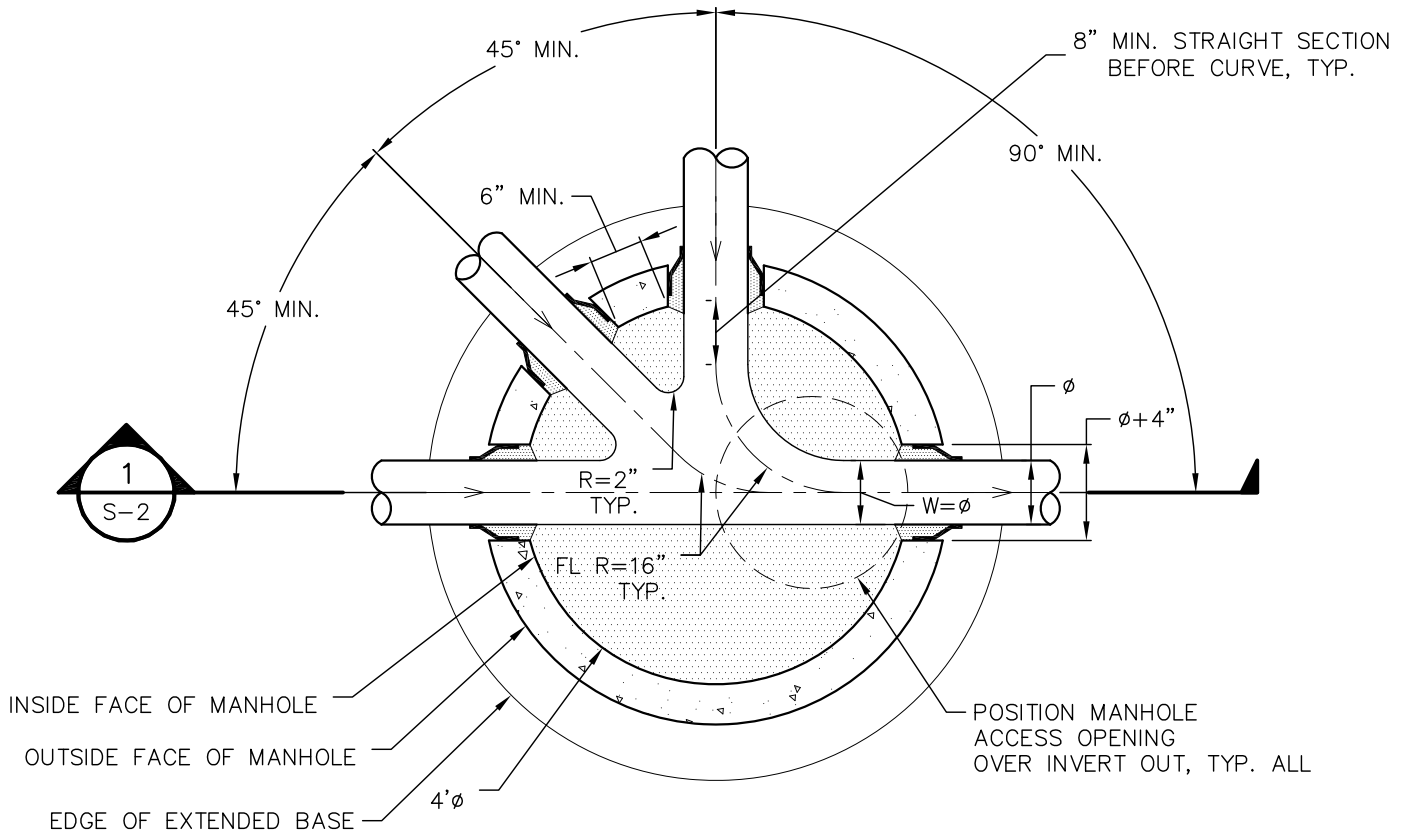

1 CHANNEL GEOMETRY
1" = 2'

 WOODMOOR WATER & SANITATION DISTRICT NO. 1	BASE GEOMETRY	S-8
	SANITARY UTILITY SEWERAGE STRUCTURES	
	<small>THIS CONSTRUCTION DETAIL SHOWS GENERAL CONFORMANCE TO SYSTEM SPECIFICATIONS AND MAY NEED TO BE ADJUSTED FOR SPECIFIC APPLICATIONS.</small>	
		<small>MAY 13, 2014</small>

SEE DRAWING S-10 FOR FINISHING IN NON-PAVED SURFACES

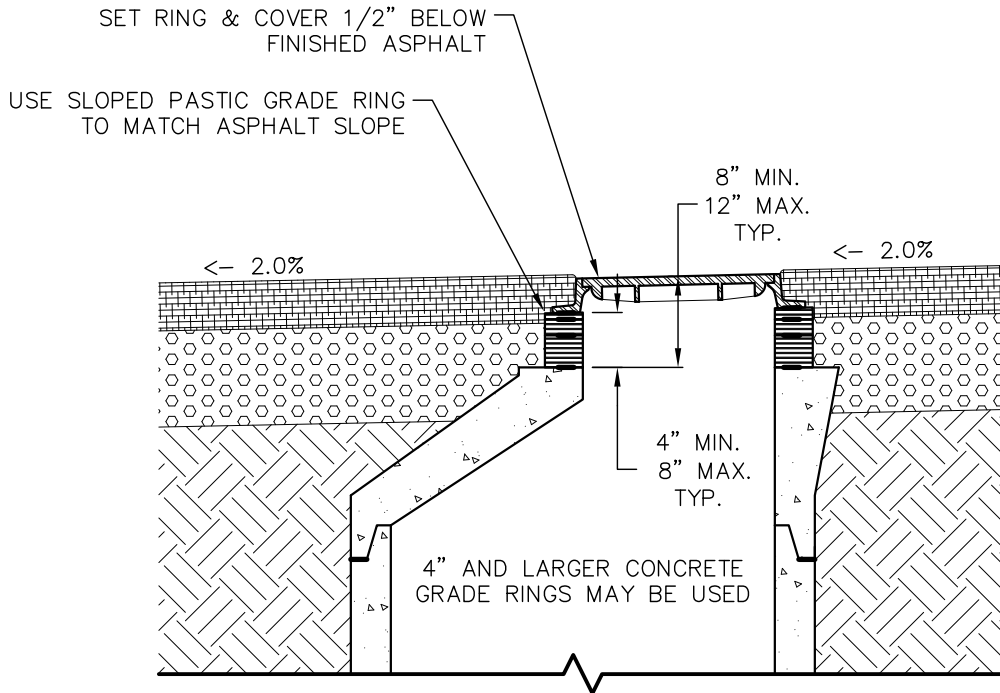

1 CONE TOP MANHOLE IN PAVEMENT
1" = 2'

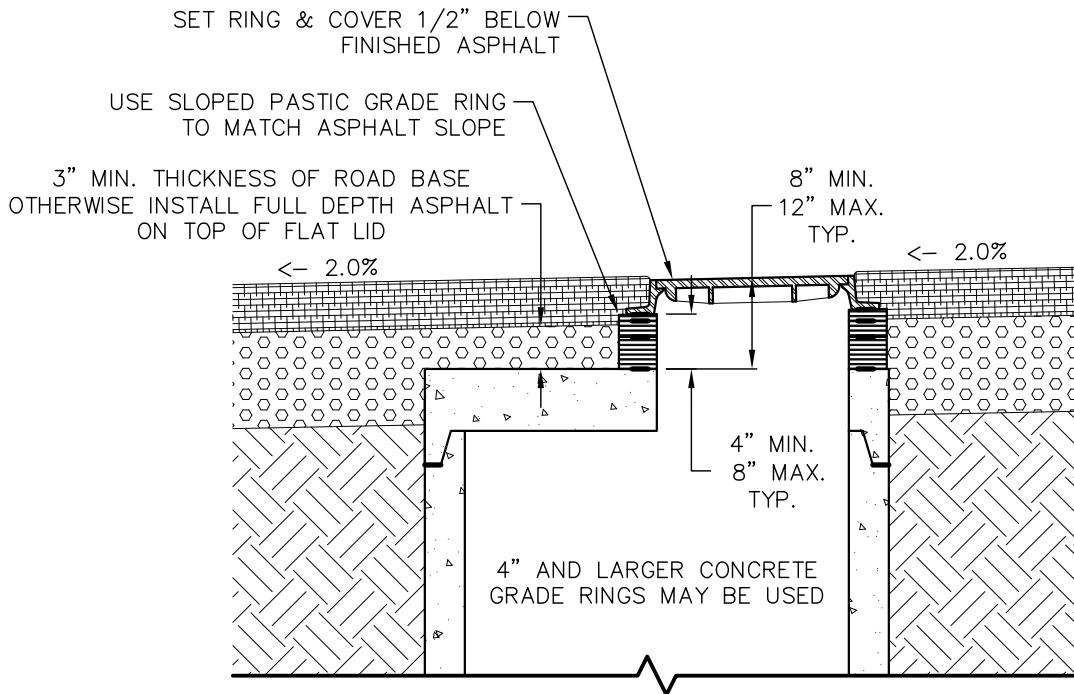

2 FLAT TOP MANHOLE IN PAVEMENT
1" = 2'



WOODMOOR
WATER & SANITATION DISTRICT NO. 1

MANHOLES IN PAVED AREAS
SANITARY UTILITY SEWERAGE STRUCTURES

S-9

33 39 00

THIS CONSTRUCTION DETAIL SHOWS GENERAL CONFORMANCE TO SYSTEM SPECIFICATIONS AND MAY NEED TO BE ADJUSTED FOR SPECIFIC APPLICATIONS.

MAY 13, 2014

SEE DRAWING S-9 FOR FINISHING IN PAVED SURFACES

APPLICATION NOTES:

- USE FLAT TOP MANHOLES IN LOCATIONS OUTSIDE OF ASPHALT

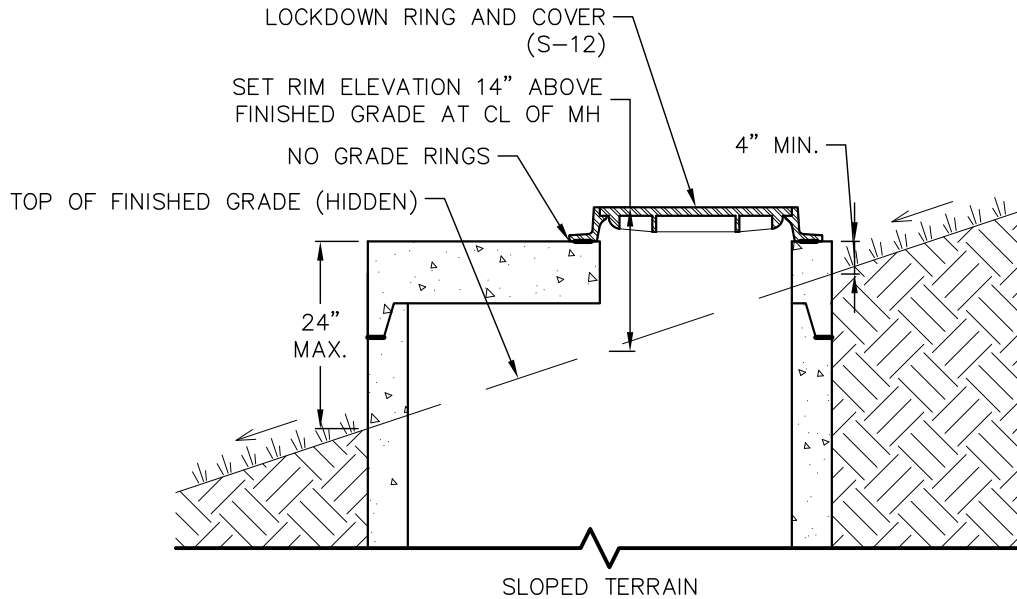

① MANHOLE OUTSIDE OF PAVEMENT
1" = 2'

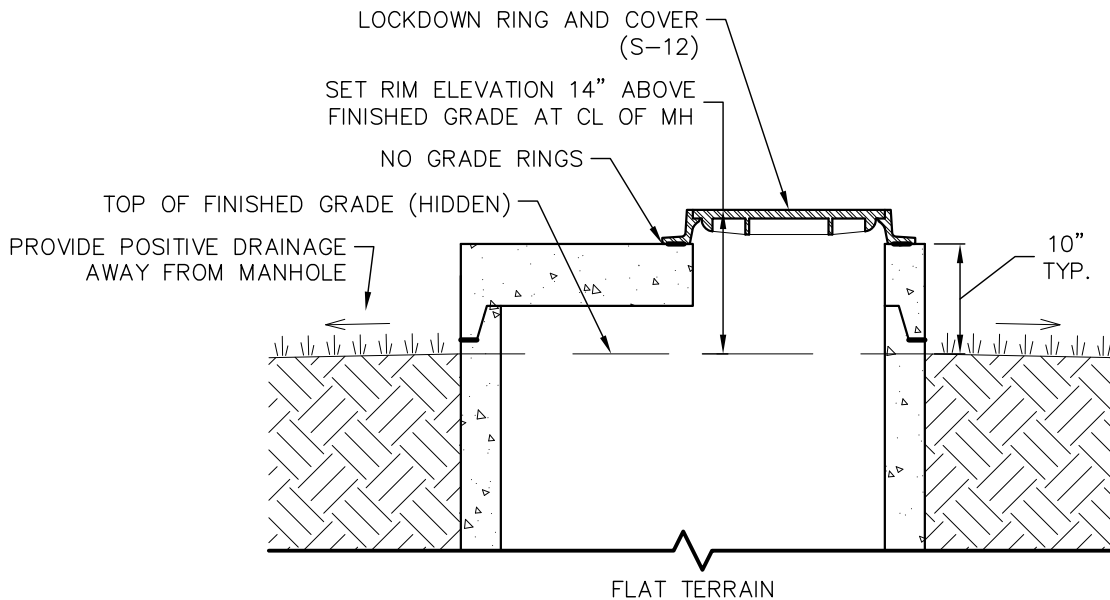

② MANHOLE OUTSIDE OF PAVEMENT
1" = 2'

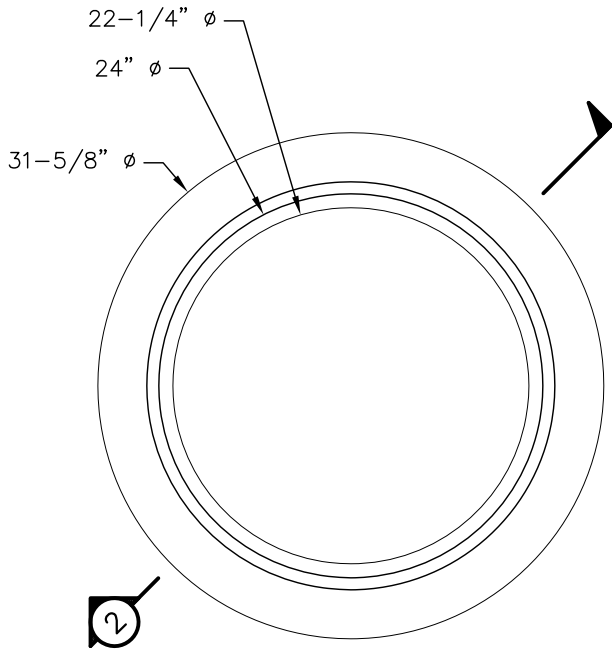

1 REGULAR RING PLAN
1" = 1'

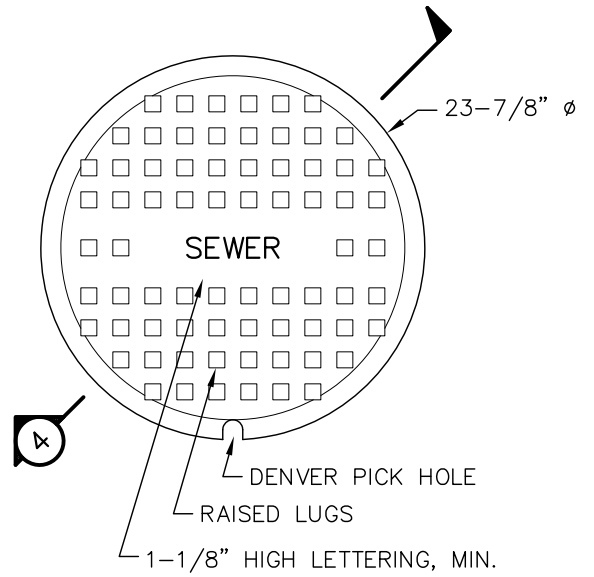

3 REGULAR COVER PLAN
1" = 1'

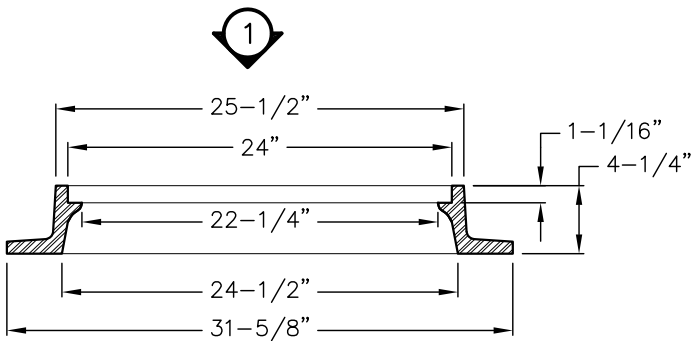

2 REGULAR RING SECTION
1" = 1'

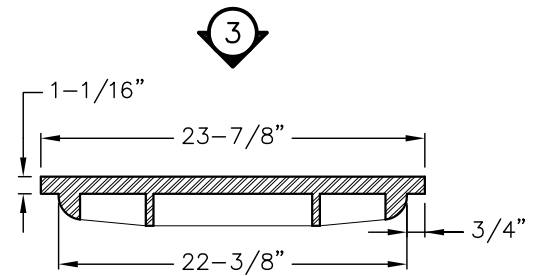

4 REGULAR COVER SECTION
1" = 1'



WOODMOOR
WATER & SANITATION DISTRICT NO. 1

STANDARD SEWER RING & COVER
SANITARY UTILITY SEWERAGE STRUCTURES

THIS CONSTRUCTION DETAIL SHOWS GENERAL CONFORMANCE TO SYSTEM SPECIFICATIONS AND MAY NEED TO BE ADJUSTED FOR SPECIFIC APPLICATIONS.

S-11

33 39 00

MAY 13, 2014

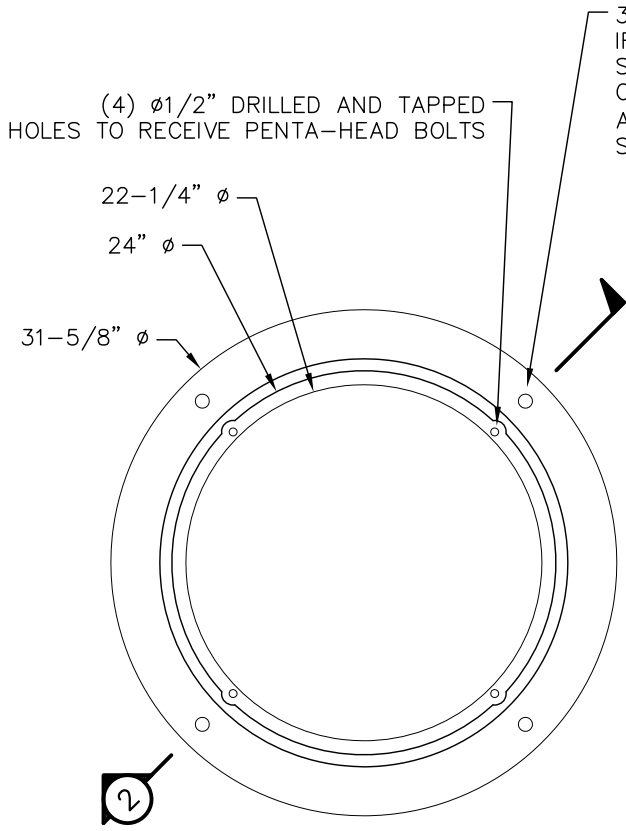

1 SECURE/FLOODPROOF RING PLAN
1" = 1'

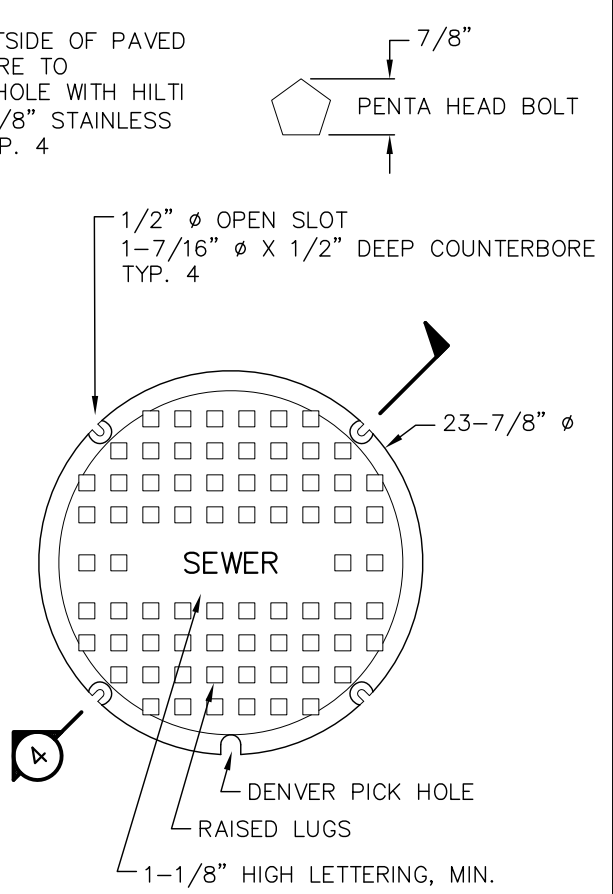

3 SECURE/FLOODPROOF COVER PLAN
1" = 1'

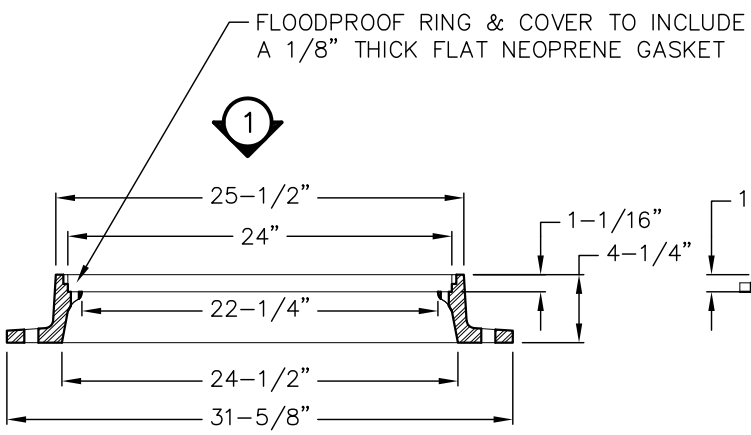

2 SECURE/FLOODPROOF RING SECTION
1" = 1'

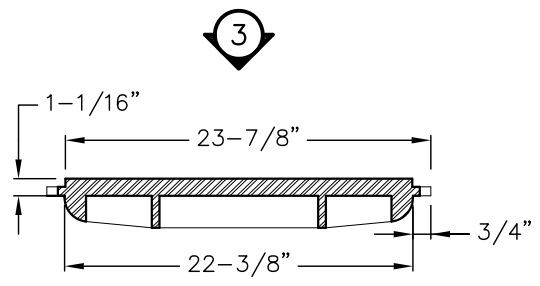

4 SECURE/FLOODPROOF COVER SECTION
1" = 1'

SEE DRAWINGS S-2 AND S-3 FOR TYPICAL MANHOLE REQUIREMENTS

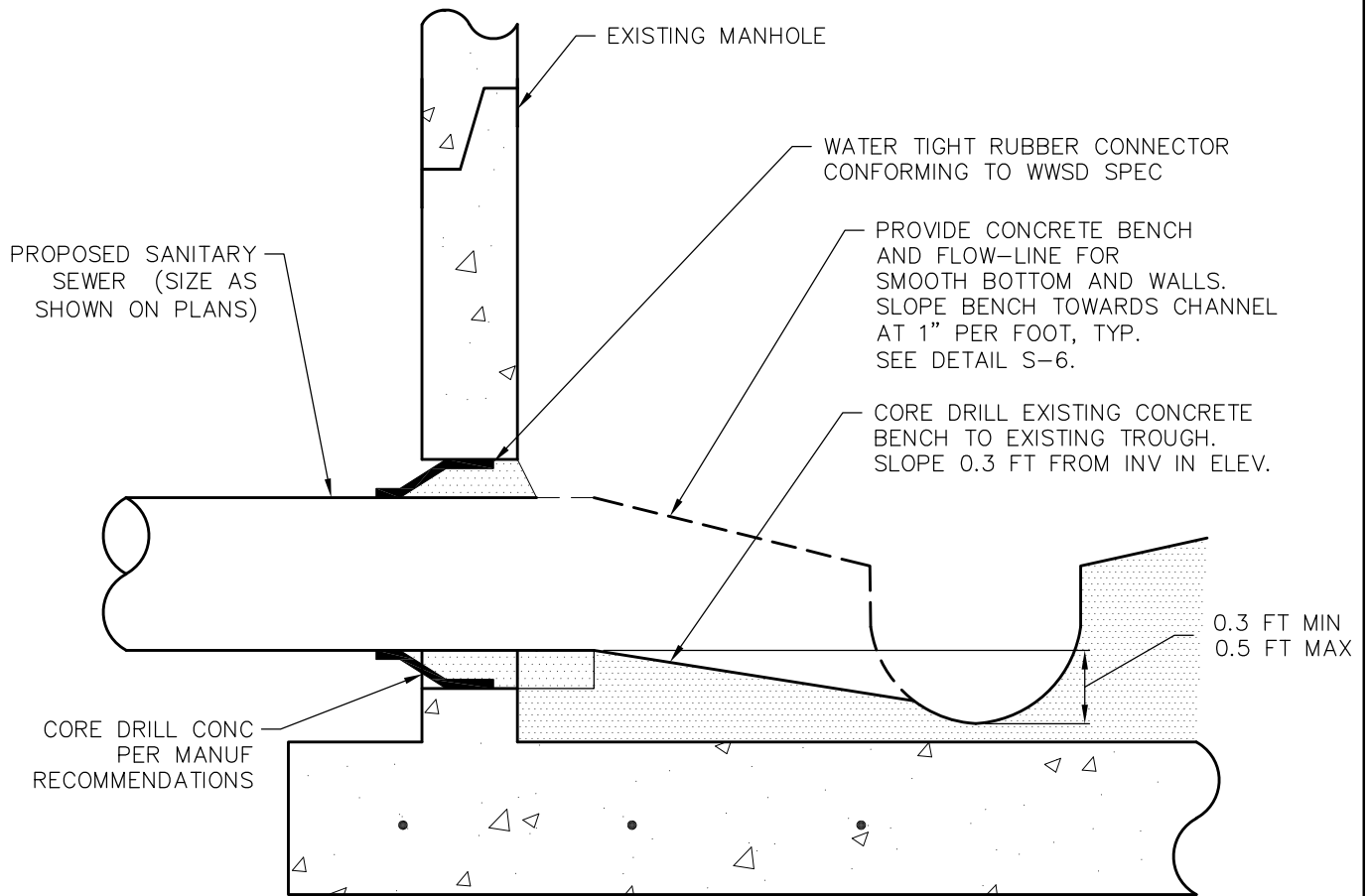

NOTE: FILL ANNULAR SPACE WITH EPOXY GROUT PER WWSO SPEC.

 <p>WOODMOOR WATER & SANITATION DISTRICT NO. 1</p>	CORE DRILLING INTO EXISTING MANHOLE	S-13
	SANITARY UTILITY SEWERAGE STRUCTURES	33 39 00
	<p>THIS CONSTRUCTION DETAIL SHOWS GENERAL CONFORMANCE TO SYSTEM SPECIFICATIONS AND MAY NEED TO BE ADJUSTED FOR SPECIFIC APPLICATIONS.</p>	

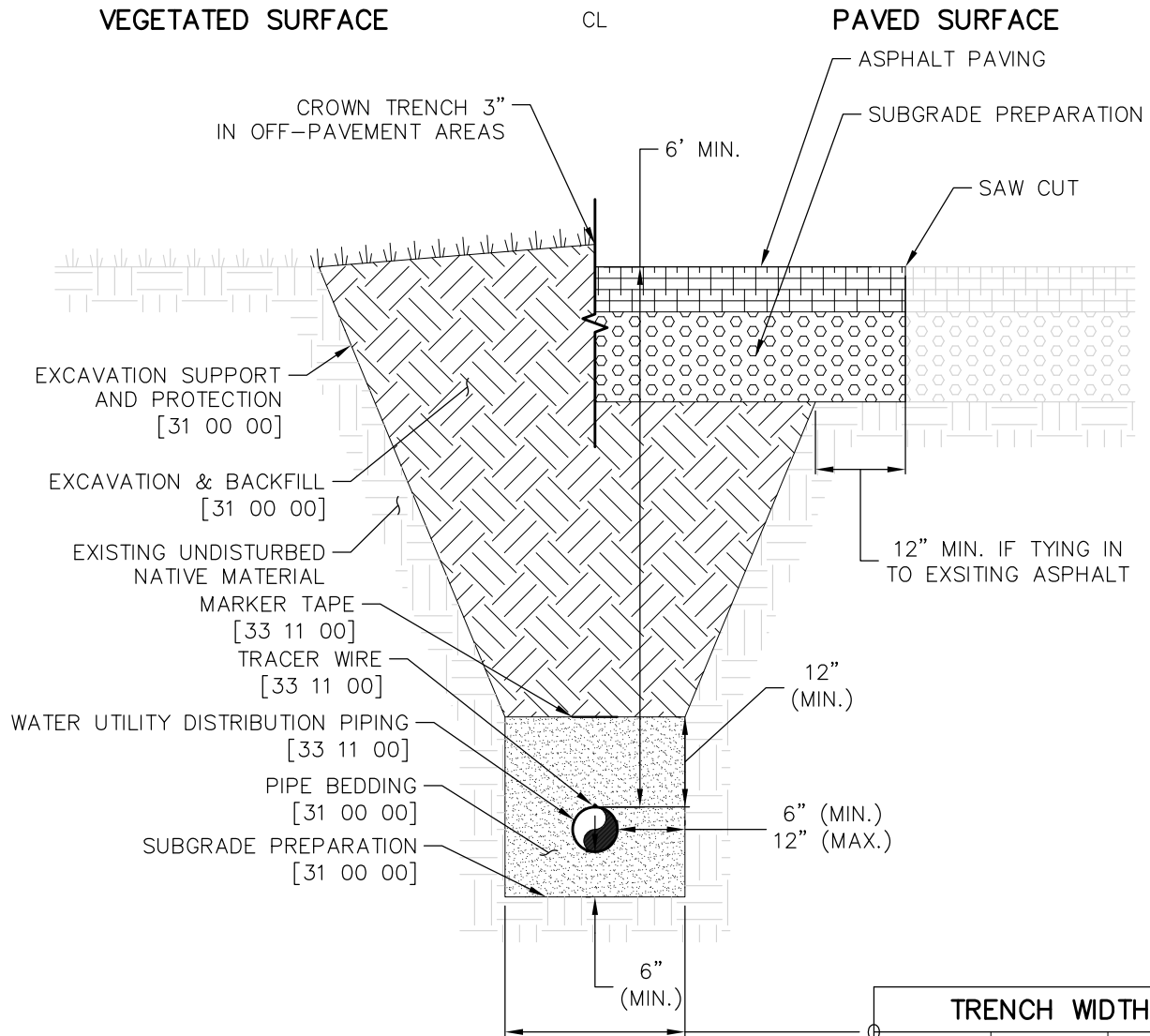

① TYPICAL WATER TRENCH (SECTION)
1"=2'

TRENCH WIDTH		
PIPE DIAMETER	MINIMUM WIDTH	MAXIMUM WIDTH
4"	1'-4"	2'-4"
6"	1'-6"	2'-6"
8"	1'-8"	2'-8"
10"	1'-10"	2'-10"
12"	2'-0"	3'-0"
14"	2'-2"	3'-2"

NOT USED



WOODMOOR
WATER & SANITATION DISTRICT NO. 1

(RESERVED)

WATER UTILITY DISTRIBUTION PIPING

THIS CONSTRUCTION DETAIL SHOWS GENERAL CONFORMANCE TO SYSTEM SPECIFICATIONS AND MAY NEED TO BE ADJUSTED FOR SPECIFIC APPLICATIONS.

W-2

33 11 00

MAY 13, 2014

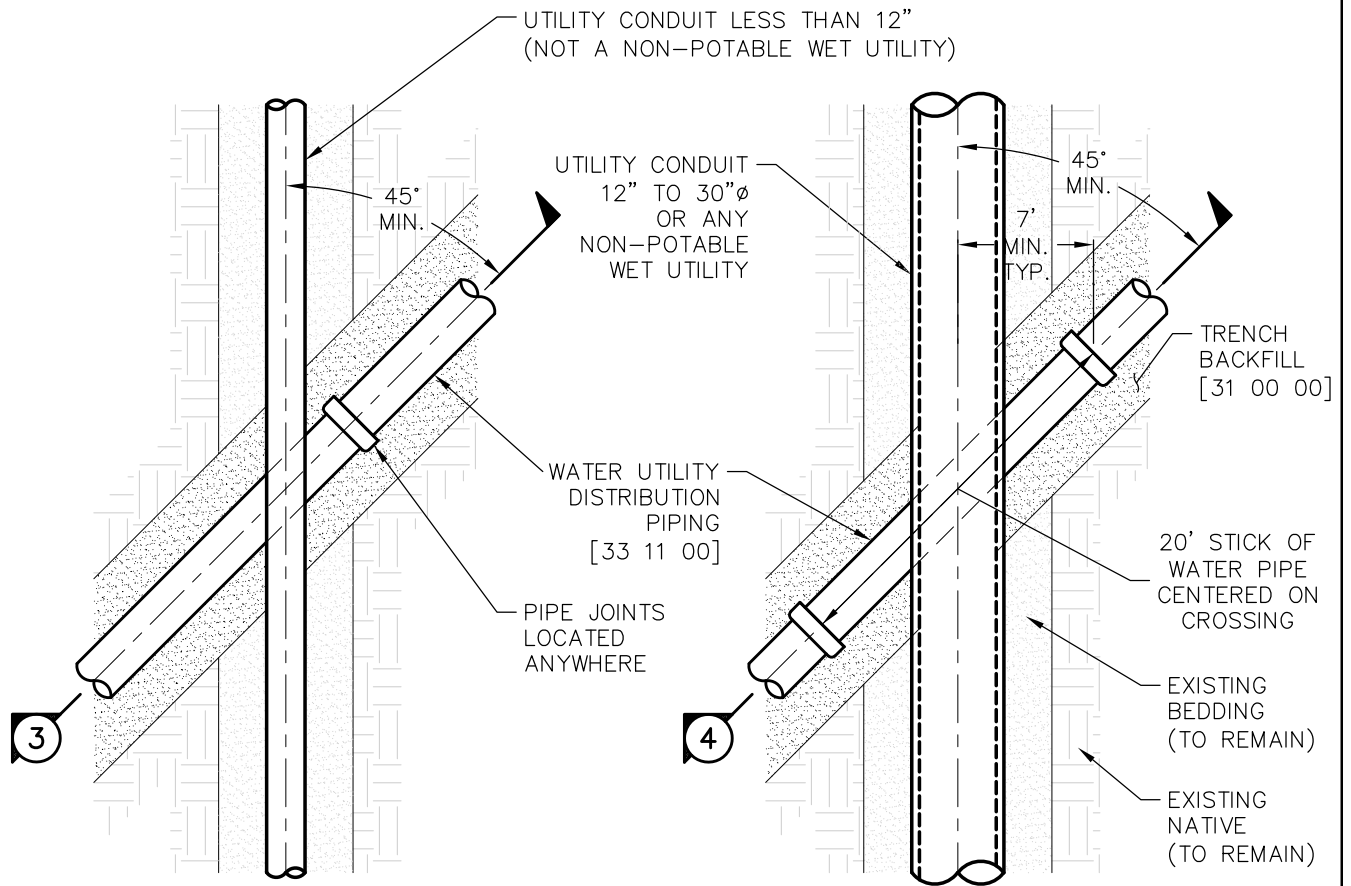

1 WATER UNDER SMALL CONDUIT (PLAN)
NOT TO SCALE

2 WATER UNDER LARGE CONDUIT (PLAN)
NOT TO SCALE

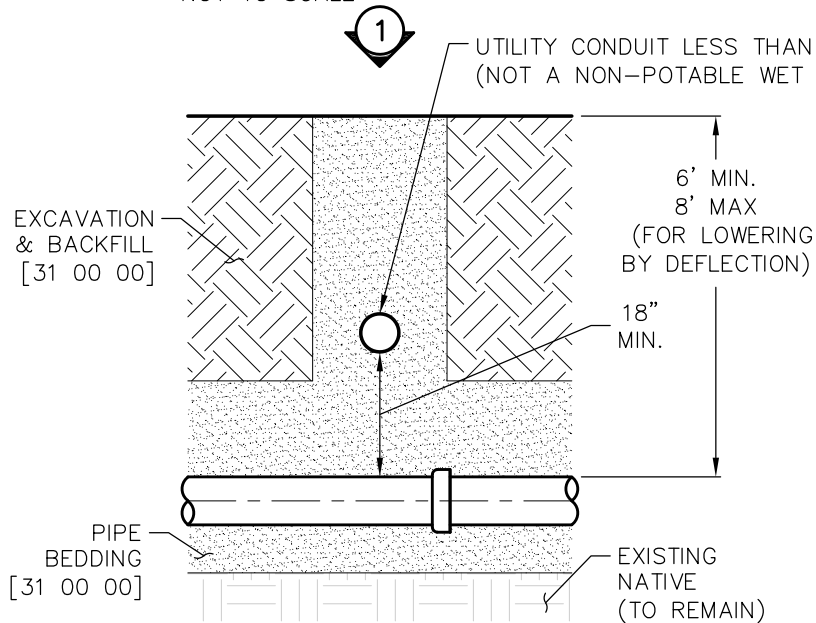

3 WATER UNDER SMALL CONDUIT (SECTION)
NOT TO SCALE

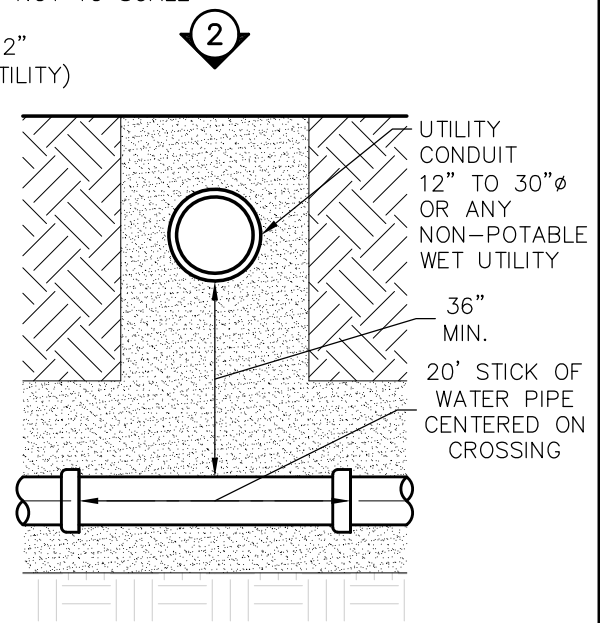

4 WATER UNDER LARGE CONDUIT (SECTION)
NOT TO SCALE



WOODMOOR
WATER & SANITATION DISTRICT NO. 1

WATER CROSSING UNDER UTILITIES

W-3

WATER UTILITY DISTRIBUTION PIPING

33 11 00

THIS CONSTRUCTION DETAIL SHOWS GENERAL CONFORMANCE TO SYSTEM SPECIFICATIONS AND MAY NEED TO BE ADJUSTED FOR SPECIFIC APPLICATIONS.

MAY 13, 2014

FOR INSTALLATIONS IN UNPAVED AREAS
SEE DRAWING W-6

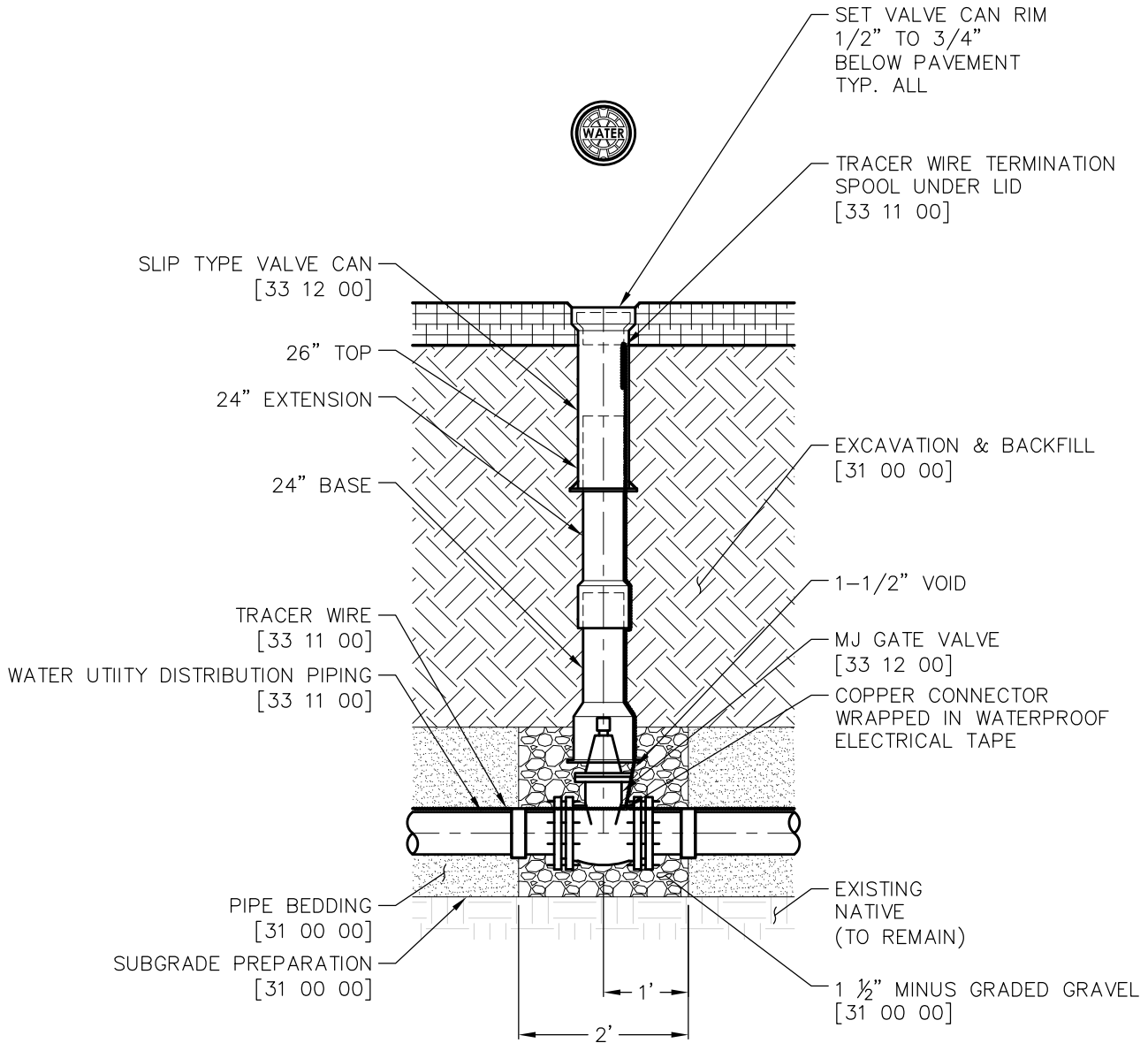

① GATE VALVE DETAIL
1"=2'

FOR INSTALLATIONS IN UNPAVED AREAS
SEE DRAWING W-6

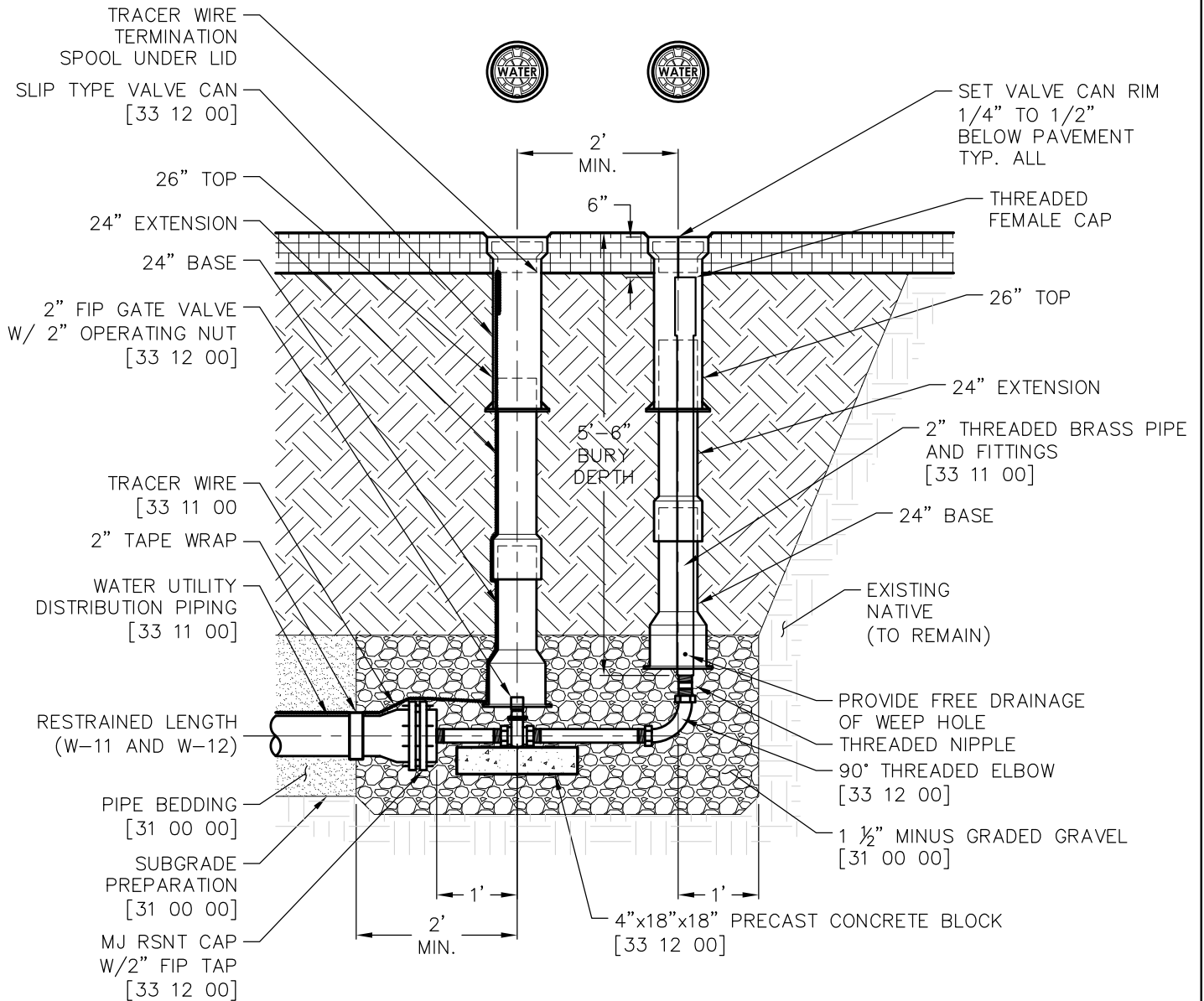

① DEAD-END BLOW-OFF (SECTION)
NOT TO SCALE

 WOODMOOR WATER & SANITATION DISTRICT NO. 1	DEAD-END BLOW-OFF ASSEMBLY	W-5
	WATER UTILITY DISTRIBUTION EQUIPMENT	33 12 00
	THIS CONSTRUCTION DETAIL SHOWS GENERAL CONFORMANCE TO SYSTEM SPECIFICATIONS AND MAY NEED TO BE ADJUSTED FOR SPECIFIC APPLICATIONS.	SEPT 1, 2022

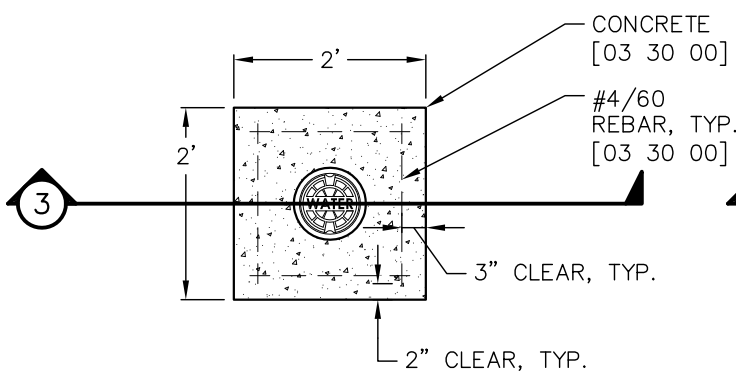

1 CONCRETE COLLAR SINGLE (PLAN)
 1"=2'

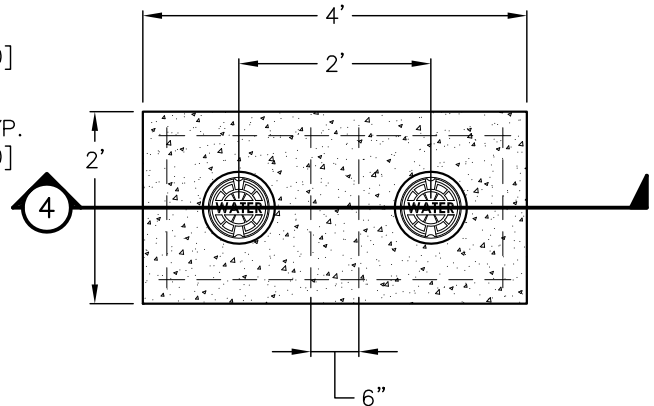

2 CONCRETE COLLAR DOUBLE (PLAN)
 1"=2'

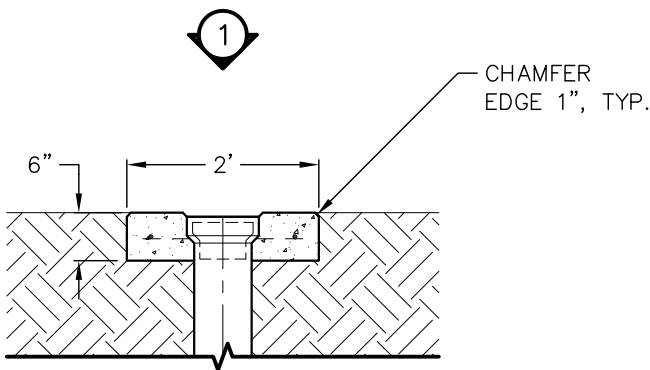

3 CONCRETE COLLAR SINGLE (SECTION)
 1"=2'

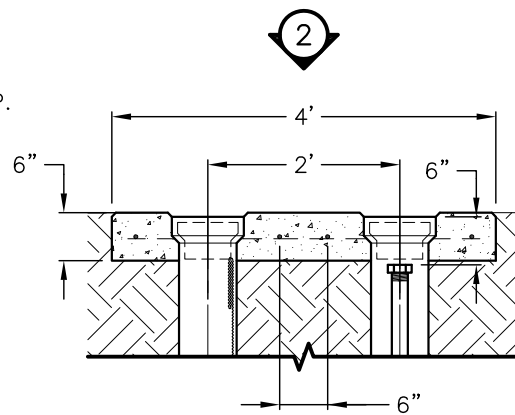

4 CONCRETE COLLAR DOUBLE (SECTION)
 1"=2'



WOODMOOR
 WATER & SANITATION DISTRICT NO. 1

VALVE CANS IN UNPAVED AREAS
 WATER UTILITY DISTRIBUTION EQUIPMENT

THIS CONSTRUCTION DETAIL SHOWS GENERAL CONFORMANCE TO SYSTEM SPECIFICATIONS AND MAY NEED TO BE ADJUSTED FOR SPECIFIC APPLICATIONS.

W-6

33 12 00

MAY 13, 2014

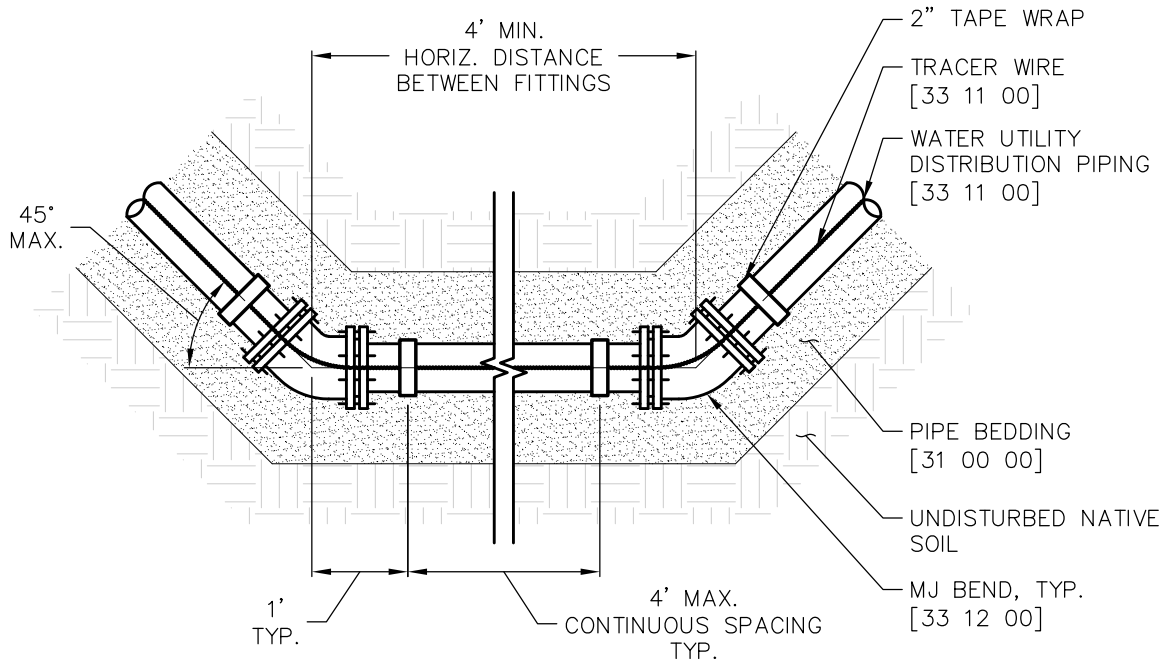

1 HORIZONTAL BENDS (PLAN)
NOT TO SCALE

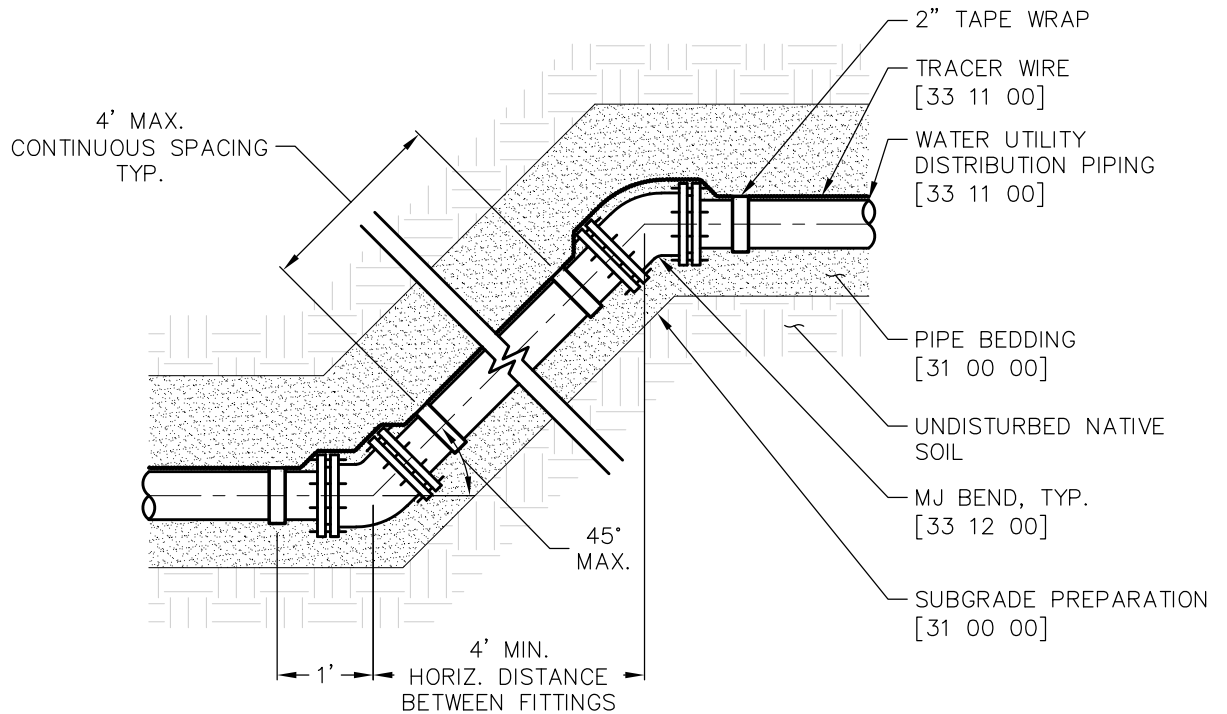

2 VERTICAL BENDS (SECTION)
NOT TO SCALE



WOODMOOR
WATER & SANITATION DISTRICT NO. 1

HORIZONTAL AND VERTICAL BENDS
WATER UTILITY DISTRIBUTION EQUIPMENT

W-7

33 12 00

THIS CONSTRUCTION DETAIL SHOWS GENERAL CONFORMANCE TO SYSTEM SPECIFICATIONS AND MAY NEED TO BE ADJUSTED FOR SPECIFIC APPLICATIONS.

MAY 13, 2014

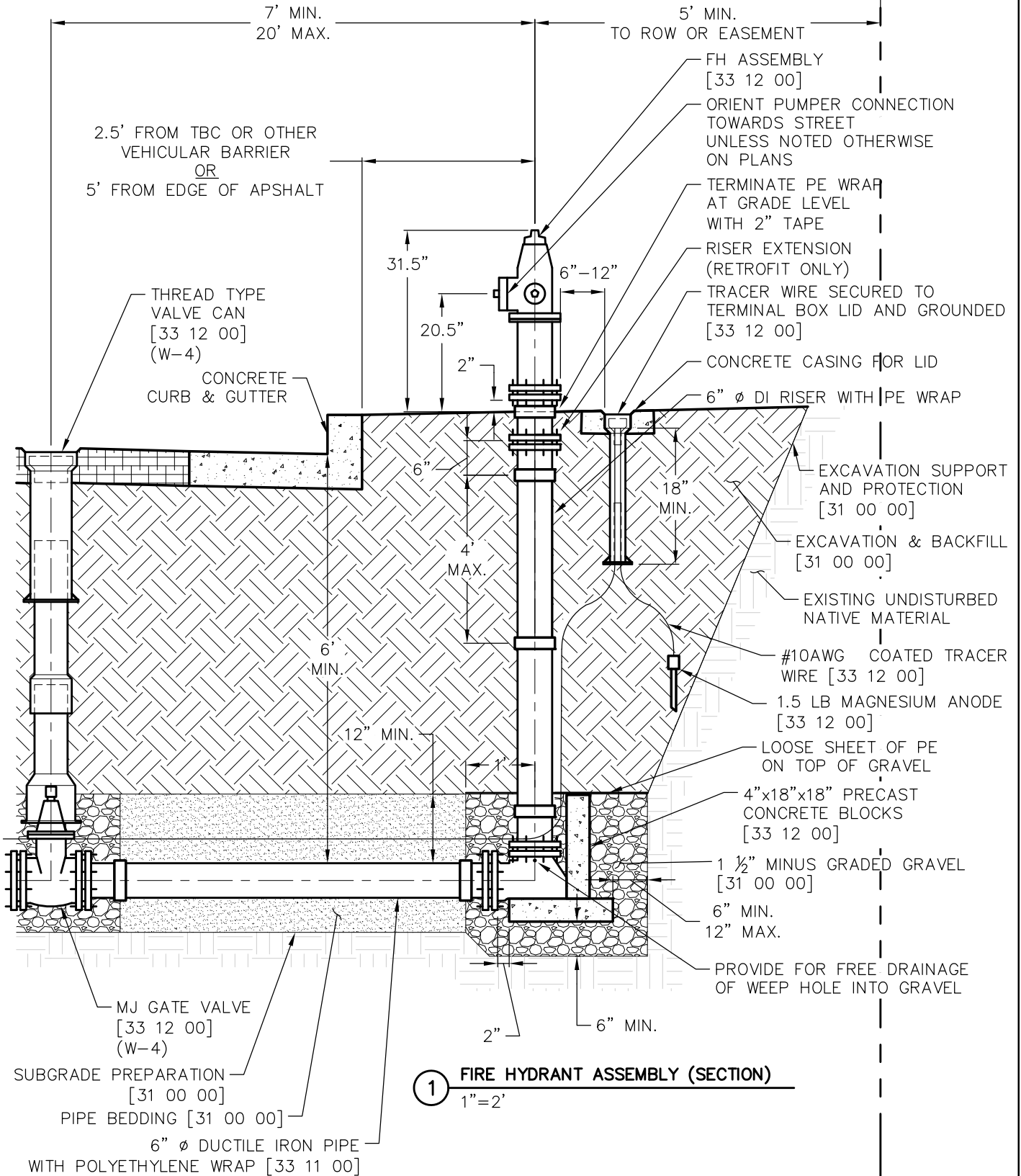

WOODMOOR
WATER & SANITATION DISTRICT NO. 1

FIRE HYDRANT ASSEMBLY
WATER UTILITY DISTRIBUTION EQUIPMENT

W-8

33 12 00

THIS CONSTRUCTION DETAIL SHOWS GENERAL CONFORMANCE TO SYSTEM SPECIFICATIONS AND MAY NEED TO BE ADJUSTED FOR SPECIFIC APPLICATIONS.

APRIL 10, 2020

GENERAL NOTES:

- EARTHWORK, TRACER WIRE, AND PIPE WRAP OMITTED FOR CLARITY.

DETAIL NOTES:

1. 18" MIN. IF CROSSING UNDER CONDUIT LESS THAN 12"Ø. 36" MIN. IF CROSSING UNDER CONDUIT 12" TO 30" DIAMETER.

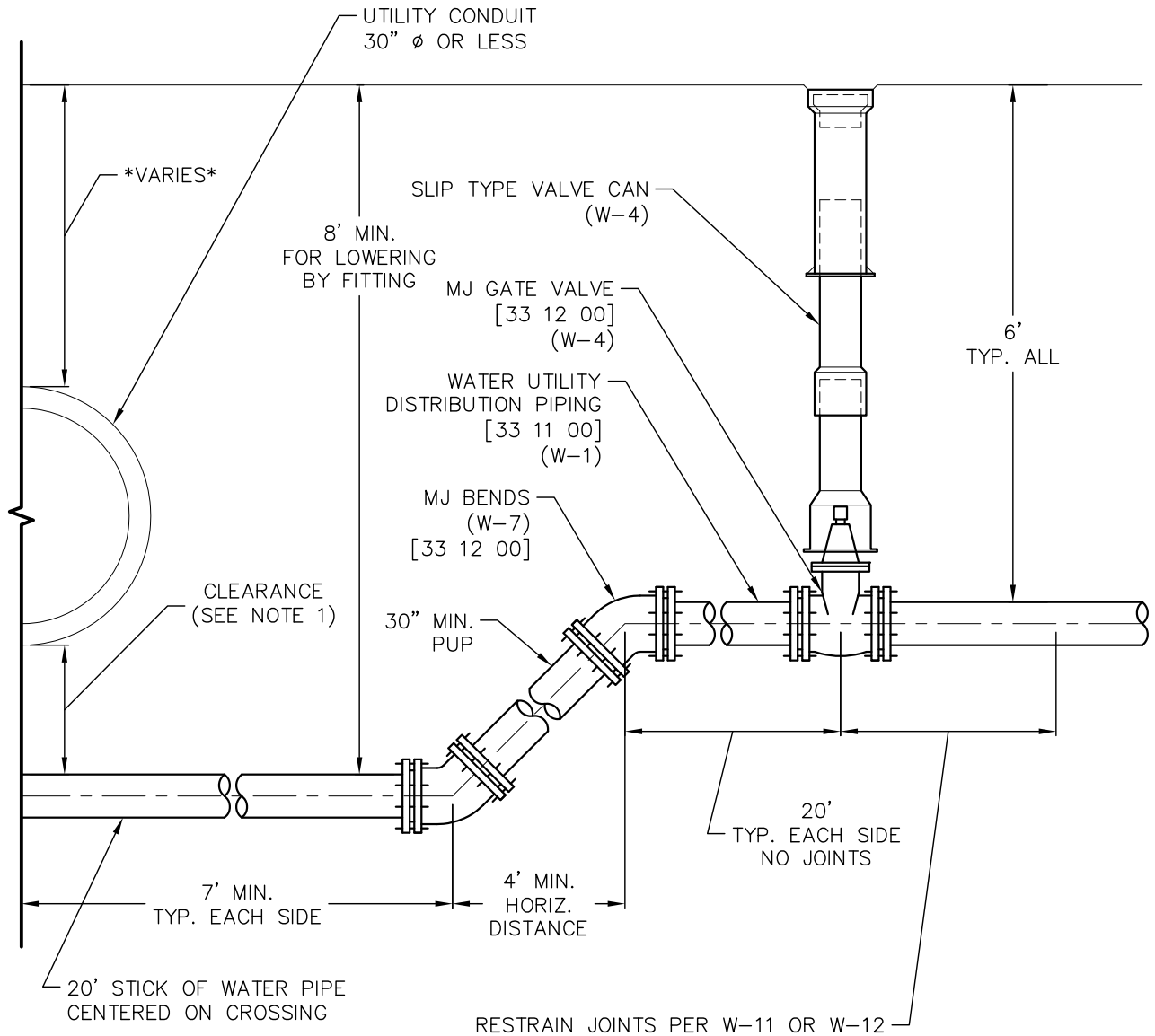

① WATER LOWERING BY FITTING (SECTION)
1"=2'

 WOODMOOR WATER & SANITATION DISTRICT NO. 1	WATER LOWERING BY FITTING	W-9
	WATER UTILITY DISTRIBUTION EQUIPMENT	33 12 00
	<small>THIS CONSTRUCTION DETAIL SHOWS GENERAL CONFORMANCE TO SYSTEM SPECIFICATIONS AND MAY NEED TO BE ADJUSTED FOR SPECIFIC APPLICATIONS.</small>	

GENERAL NOTES:

- EARTHWORK, TRACER WIRE, AND PIPE WRAP OMITTED FOR CLARITY.
- THIS DRAWING APPLICABLE FOR TEE AND CROSS FITTINGS.

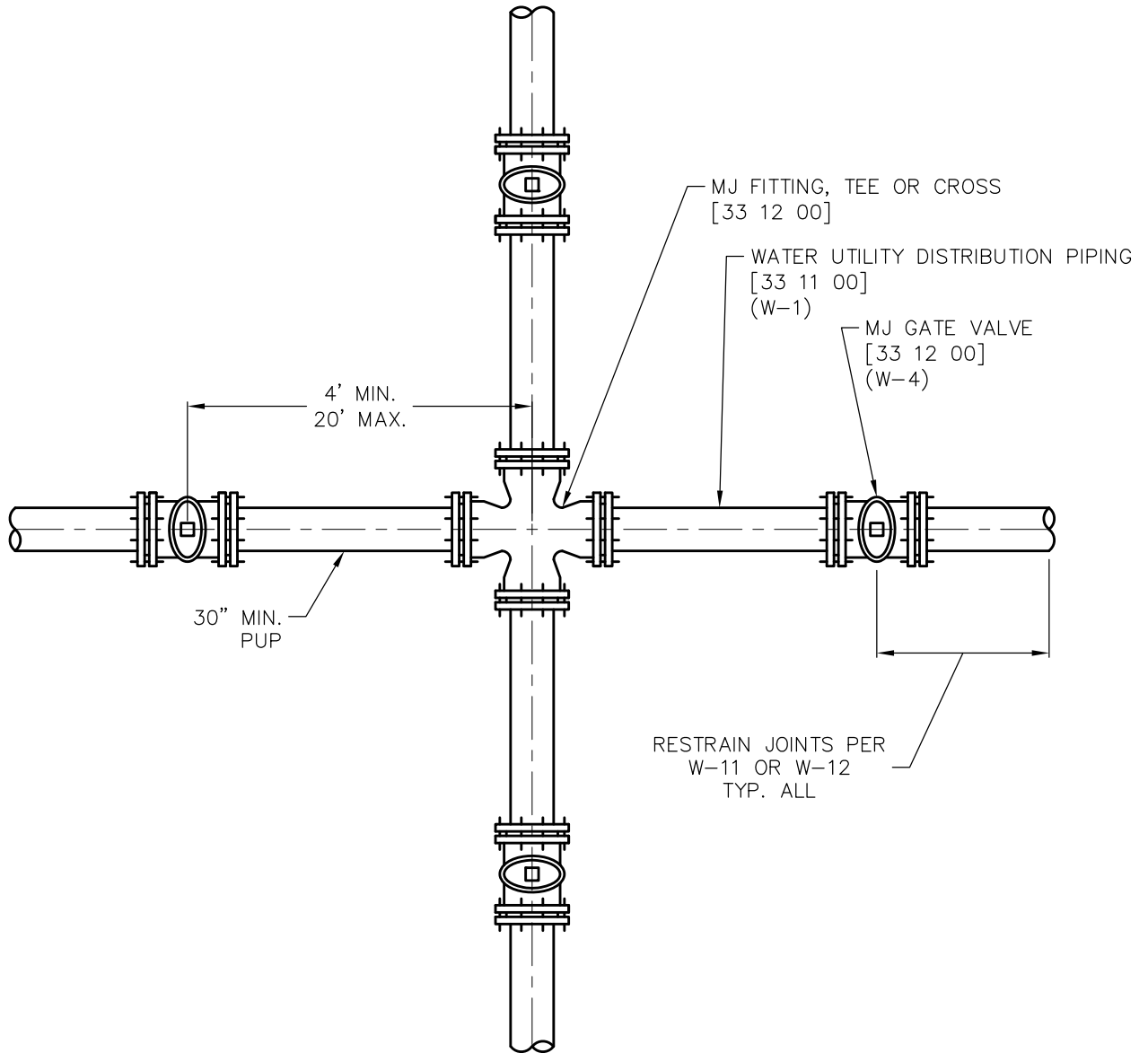

① TYPICAL JUNCTION ASSEMBLY (PLAN)
1"=2'

 <p>WOODMOOR WATER & SANITATION DISTRICT NO. 1</p>	WATER MAIN JUNCTION	W-10
	WATER UTILITY DISTRIBUTION EQUIPMENT	33 12 00
	THIS CONSTRUCTION DETAIL SHOWS GENERAL CONFORMANCE TO SYSTEM SPECIFICATIONS AND MAY NEED TO BE ADJUSTED FOR SPECIFIC APPLICATIONS.	MAY 13, 2014

TEE'S			
NOMINAL RUN DIAMETER	NOMINAL BRANCH DIAMETER	RUN	BRANCH
[IN]	[IN]	[FT]	[FT]
4"	4"	10	F.O.
4"	6"	10	8
4"	8"	10	42
6"	4"	10	F.O.
6"	6"	10	F.O.
6"	8"	10	21
8"	4"	10	F.O.
8"	6"	10	F.O.
8"	8"	10	2

CALCULATION METHOD & ASSUMPTIONS
EBAA IRON RESTRAINED LENGTH CALCULATOR (VERSION 5.4)

PIPE MATERIAL: PVC
 SOIL TYPE: CH, GRAN. FILL
 SAFETY FACTOR: 1.5:1
 TRENCH TYPE: 5
 DEPTH OF BURY: 6 FEET
 TEST PRESSURE: 200 PSI

REDUCERS		
NOMINAL LARGE DIAMETER	NOMINAL SMALL DIAMETER	LENGTH
[IN]	[IN]	[FT]
6"	4"	32
8"	4"	59
8"	6"	35

DEAD-ENDS AND VALVES	
NOMINAL PIPE DIAMETER	LENGTH
[IN]	[FT]
4"	44
6"	62
8"	82

HORIZONTAL AND VERTICAL BENDS										
NOMINAL PIPE DIAMETER	HORIZONTAL BENDS				VERTICAL BENDS (OFFSETS)					
					45°		22.5°		12.5°	
	90°	45°	22.5°	11.25°	UPPER	LOWER	UPPER	LOWER	UPPER	LOWER
[IN]	[FT]	[FT]	[FT]	[FT]	[FT]	[FT]	[FT]	[FT]	[FT]	[FT]
4"	90°	5	3	2	19	5	9	3	5	2
6"	BENDS NOT ALLOWED	7	4	2	26	7	13	3	7	2
8"	ALLOWED	10	5	3	34	8	17	4	9	2

NOTES:

1. RESTRAINED PIPE LENGTH SHALL BE ACHIEVED WITH MECHANICAL JOINT RESTRAINTS OR BELL RESTRAINTS. DO NOT USE THREADED TIE RODS OR CONCRETE KICKER BLOCKS.
2. FOR VALVES, BENDS, AND TEE RUNS THE LENGTHS OF TIED PIPES ARE MEASURED EACH WAY.
3. FOR DEAD-ENDS, TEE BRANCHES, AND REDUCERS THE LENGTHS OF TIED PIPE ARE MEASURED ONE WAY IN THE OPPOSITE DIRECTION OF THE APPLIED THRUST.
4. F.O. = MECHANICAL JOINT RESTRAINT AT FITTING ONLY.



WOODMOOR
 WATER & SANITATION DISTRICT NO. 1

LENGTH OF RESTRAINED PIPE (PVC)
 WATER UTILITY DISTRIBUTION EQUIPMENT

W-11
 33 12 00

THIS CONSTRUCTION DETAIL SHOWS GENERAL CONFORMANCE TO SYSTEM SPECIFICATIONS AND MAY NEED TO BE ADJUSTED FOR SPECIFIC APPLICATIONS.

MAY 13, 2014

TEE'S			
NOMINAL RUN DIAMETER	NOMINAL BRANCH DIAMETER	RUN	BRANCH
[IN]	[IN]	[FT]	[FT]
4"	4"	10	F.O.
4"	6"	10	5
4"	8"	10	26
6"	4"	10	F.O.
6"	6"	10	F.O.
6"	8"	10	13
8"	4"	10	F.O.
8"	6"	10	F.O.
8"	8"	10	F.O.

CALCULATION METHOD & ASSUMPTIONS
EBAA IRON RESTRAINED LENGTH CALCULATOR (VERSION 5.4)

PIPE MATERIAL: DIP WITH POLYETHYLENE ENCASEMENT
 SOIL TYPE: CH, GRAN. FILL
 SAFETY FACTOR: 1.5:1
 TRENCH TYPE: 5
 DEPTH OF BURY: 6 FEET
 TEST PRESSURE: 200 PSI

REDUCERS		
NOMINAL LARGE DIAMETER	NOMINAL SMALL DIAMETER	LENGTH
[IN]	[IN]	[FT]
6"	4"	21
8"	4"	38
8"	6"	22

DEAD-ENDS AND VALVES	
NOMINAL PIPE DIAMETER	LENGTH
[IN]	[FT]
4"	28
6"	40
8"	53

HORIZONTAL AND VERTICAL OFFSETS										
NOMINAL PIPE DIAMETER	HORIZONTAL BENDS				VERTICAL OFFSETS					
					45°		22.5°		12.5°	
	90°	45°	22.5°	11.25°	UPPER	LOWER	UPPER	LOWER	UPPER	LOWER
[IN]	[FT]	[FT]	[FT]	[FT]	[FT]	[FT]	[FT]	[FT]	[FT]	[FT]
4"	90° BENDS NOT ALLOWED	5	3	2	12	4	6	2	3	F.O.
6"		7	3	2	17	6	8	3	4	2
8"		8	4	2	22	7	11	4	6	2

NOTES:

1. RESTRAINED PIPE LENGTH SHALL BE ACHIEVED WITH MECHANICAL JOINT RESTRAINTS OR BELL RESTRAINTS. DO NOT USE THREADED TIE RODS OR CONCRETE KICKER BLOCKS.
2. FOR VALVES, BENDS, AND TEE RUNS THE LENGTHS OF TIED PIPES ARE MEASURED EACH WAY.
3. FOR DEAD-ENDS, TEE BRANCHES, AND REDUCERS THE LENGTHS OF TIED PIPE ARE MEASURED ONE WAY IN THE OPPOSITE DIRECTION OF THE APPLIED THRUST.
4. F.O. = MECHANICAL JOINT RESTRAINT AT FITTING ONLY.

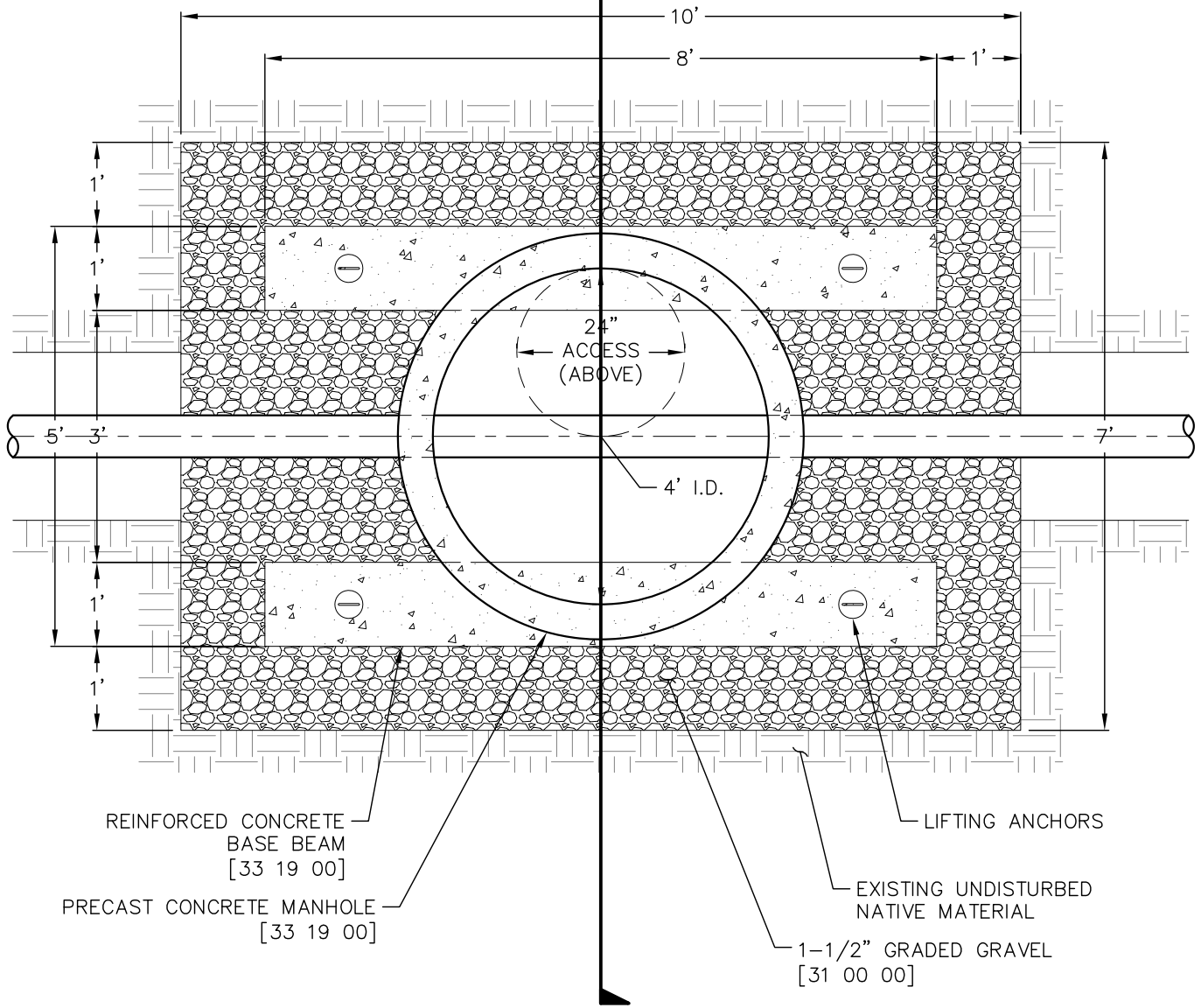
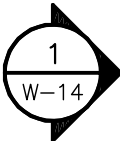

REINFORCED CONCRETE BASE BEAM [33 19 00]

PRECAST CONCRETE MANHOLE [33 19 00]

LIFTING ANCHORS

EXISTING UNDISTURBED NATIVE MATERIAL

1-1/2" GRADED GRAVEL [31 00 00]

1 AIR/VAC VAULT (PLAN)
1"=2'

	PRECAST CIRCULAR WATER VAULT	W-13
	WATER UTILITY STRUCTURES	33 19 00
	THIS CONSTRUCTION DETAIL SHOWS GENERAL CONFORMANCE TO SYSTEM SPECIFICATIONS AND MAY NEED TO BE ADJUSTED FOR SPECIFIC APPLICATIONS.	MAY 13, 2014

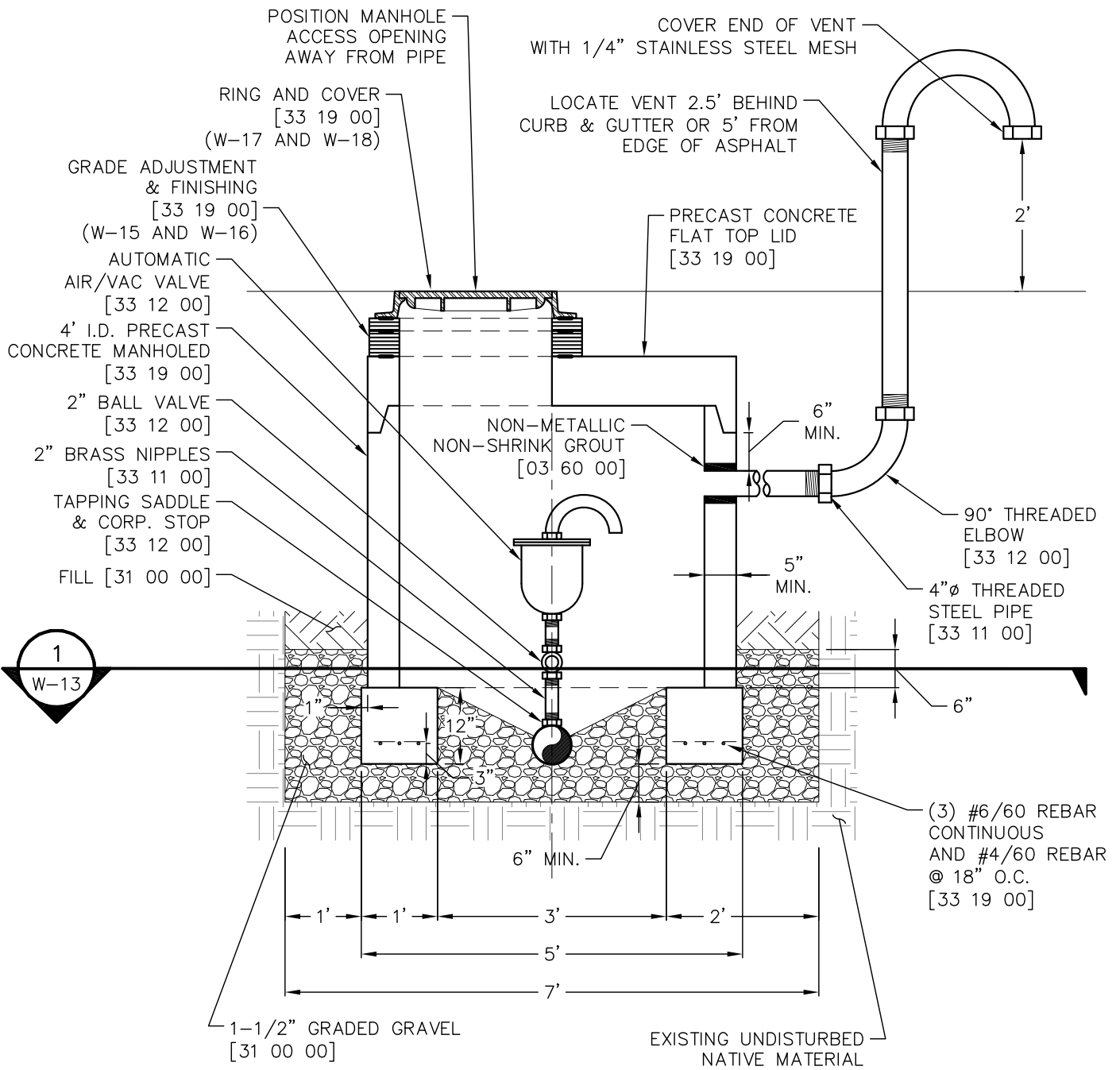

1 AIR/VAC VAULT (SECTION)
1"=2'



WOODMOOR
WATER & SANITATION DISTRICT NO. 1

PRECAST CIRCULAR WATER VAULT

WATER UTILITY STRUCTURES

THIS CONSTRUCTION DETAIL SHOWS GENERAL CONFORMANCE TO SYSTEM SPECIFICATIONS AND MAY NEED TO BE ADJUSTED FOR SPECIFIC APPLICATIONS.

W-14

33 19 00

MAY 13, 2014

SEE DRAWING W-16 FOR FINISHING IN NON-PAVED SURFACES

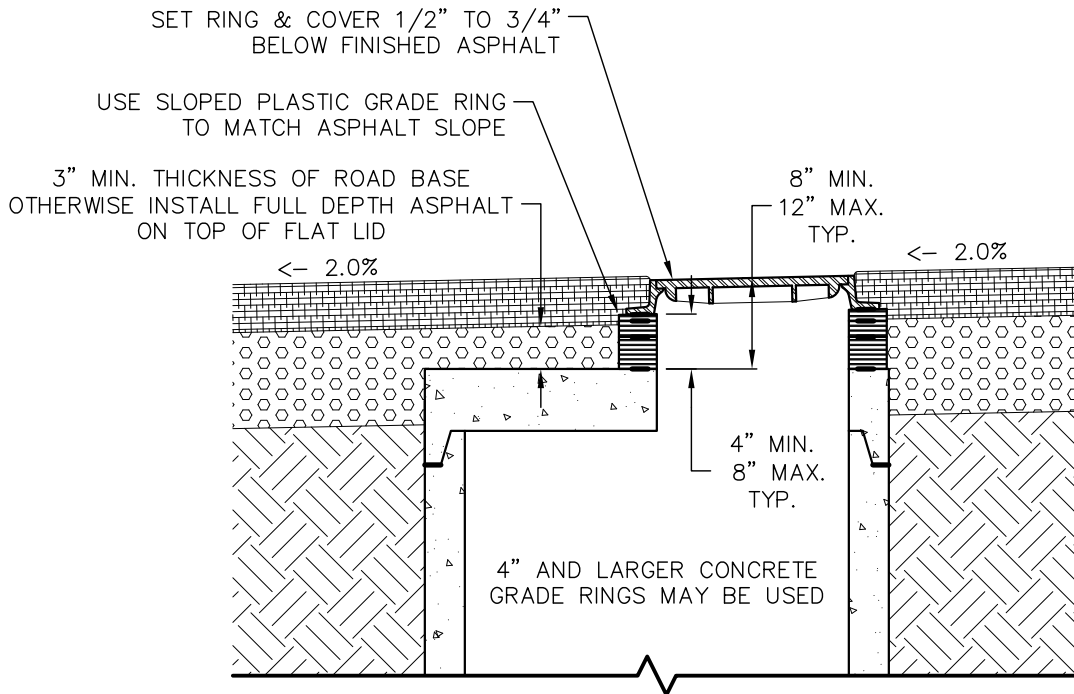

1 FLAT TOP MANHOLE IN PAVEMENT
1" = 2'



WOODMOOR
WATER & SANITATION DISTRICT NO. 1

MANHOLES IN PAVED AREAS

WATER UTILITY STRUCTURES

THIS CONSTRUCTION DETAIL SHOWS GENERAL CONFORMANCE TO SYSTEM SPECIFICATIONS AND MAY NEED TO BE ADJUSTED FOR SPECIFIC APPLICATIONS.

W-15

33 19 00

MAY 13, 2014

SEE DRAWING W-15 FOR FINISHING IN PAVED SURFACES

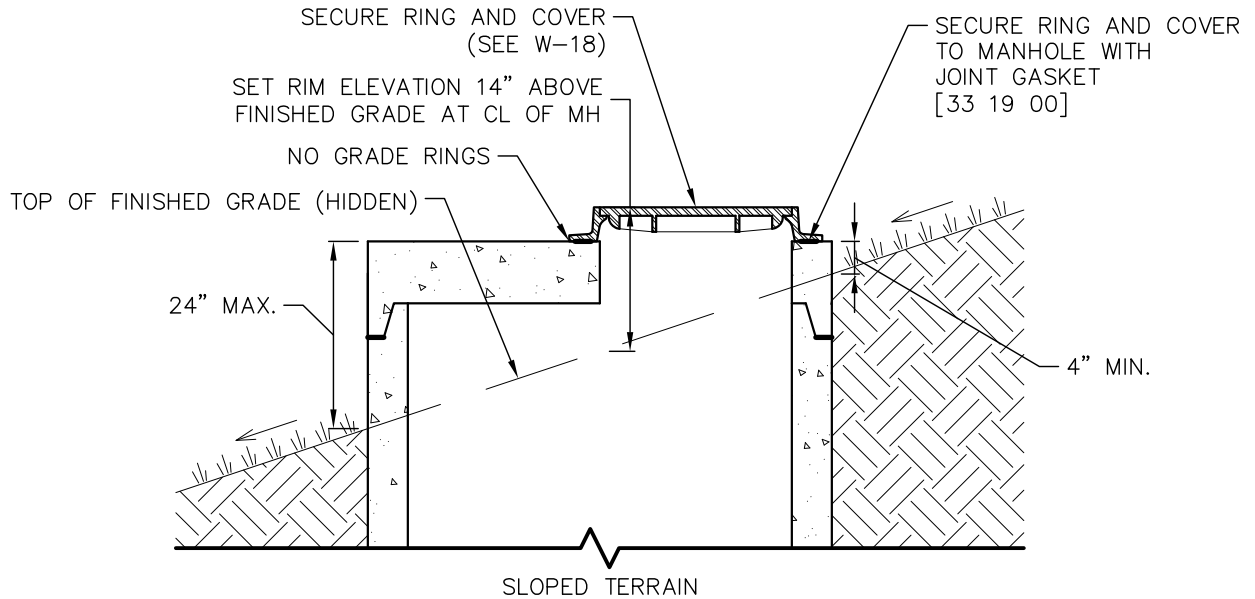

1 MANHOLE OUTSIDE OF PAVEMENT
1" = 2'

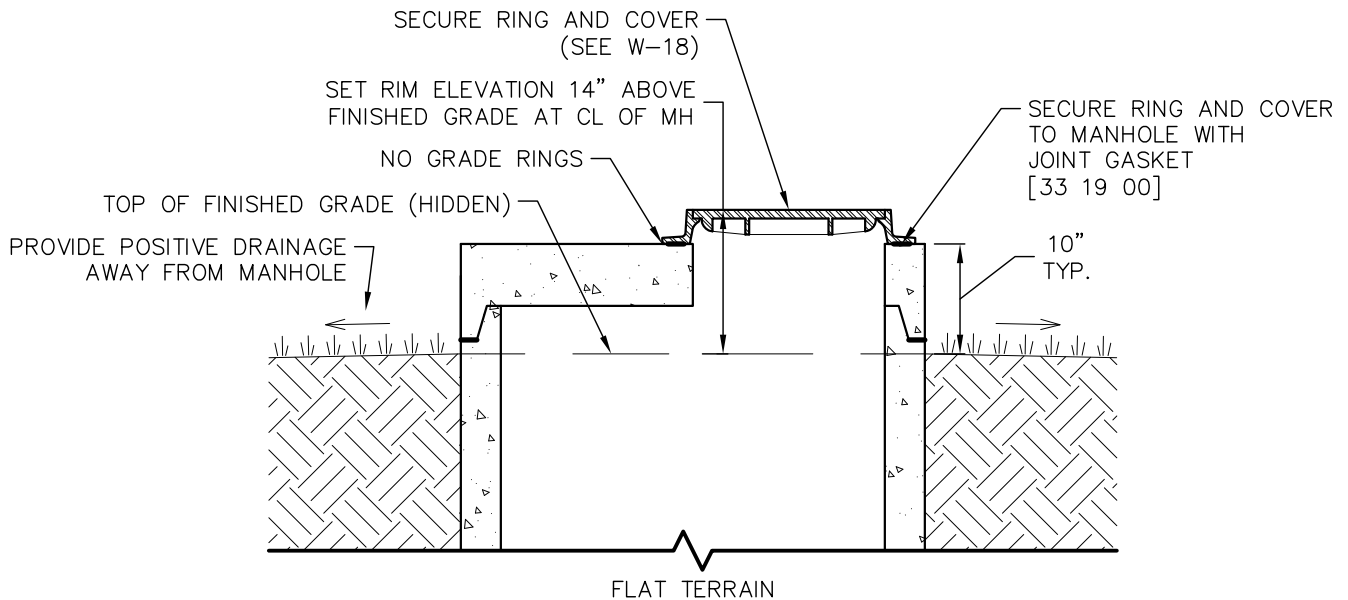

2 MANHOLE OUTSIDE OF PAVEMENT
1" = 2'



WOODMOOR
WATER & SANITATION DISTRICT NO. 1

MANHOLES IN UNPAVED AREAS

W-16

WATER UTILITY STRUCTURES

33 19 00

THIS CONSTRUCTION DETAIL SHOWS GENERAL CONFORMANCE TO SYSTEM SPECIFICATIONS AND MAY NEED TO BE ADJUSTED FOR SPECIFIC APPLICATIONS.

MAY 13, 2014

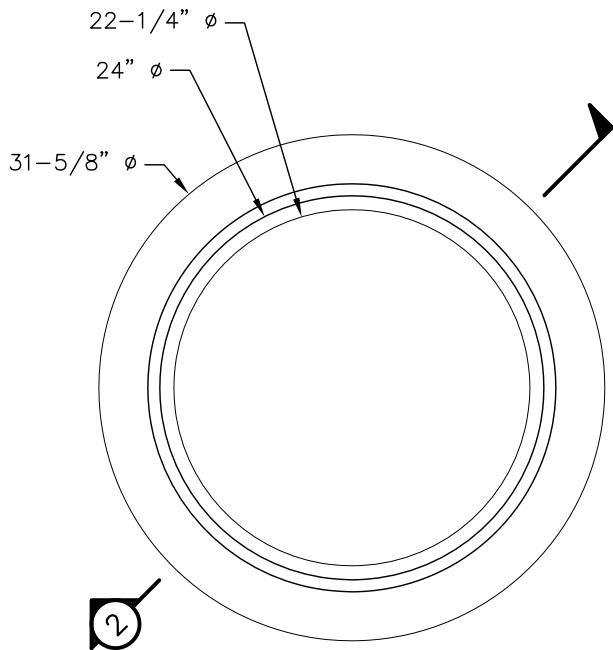

1 REGULAR RING PLAN
1" = 1'

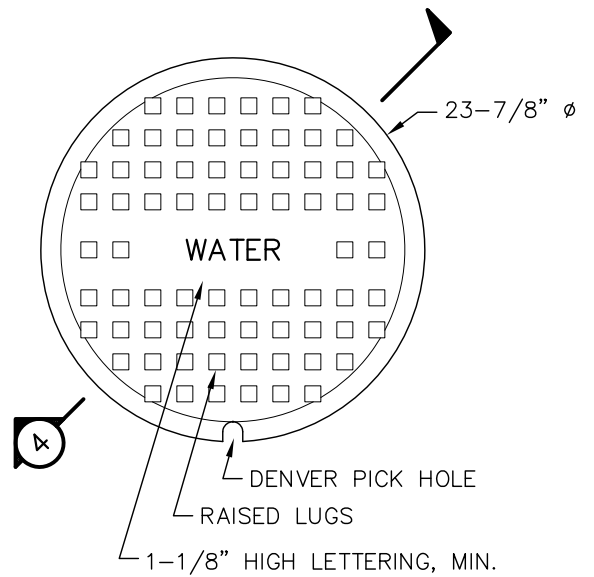

3 REGULAR COVER PLAN
1" = 1'

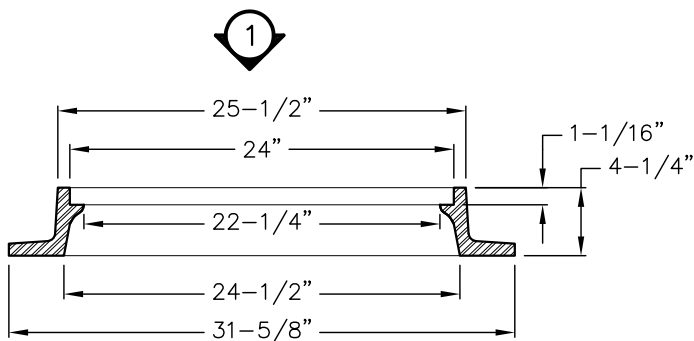

2 REGULAR RING SECTION
1" = 1'

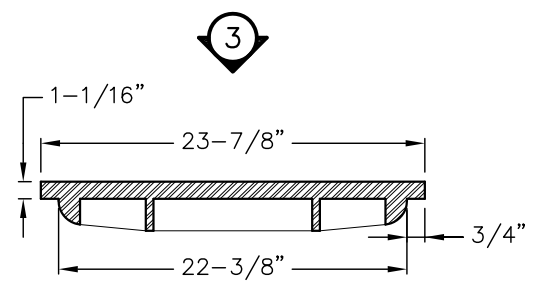

4 REGULAR COVER SECTION
1" = 1'



WOODMOOR
WATER & SANITATION DISTRICT NO. 1

STANDARD WATER RING & COVER

WATER UTILITY STRUCTURES

THIS CONSTRUCTION DETAIL SHOWS GENERAL CONFORMANCE TO SYSTEM SPECIFICATIONS AND MAY NEED TO BE ADJUSTED FOR SPECIFIC APPLICATIONS.

W-17

33 19 00

MAY 13, 2014

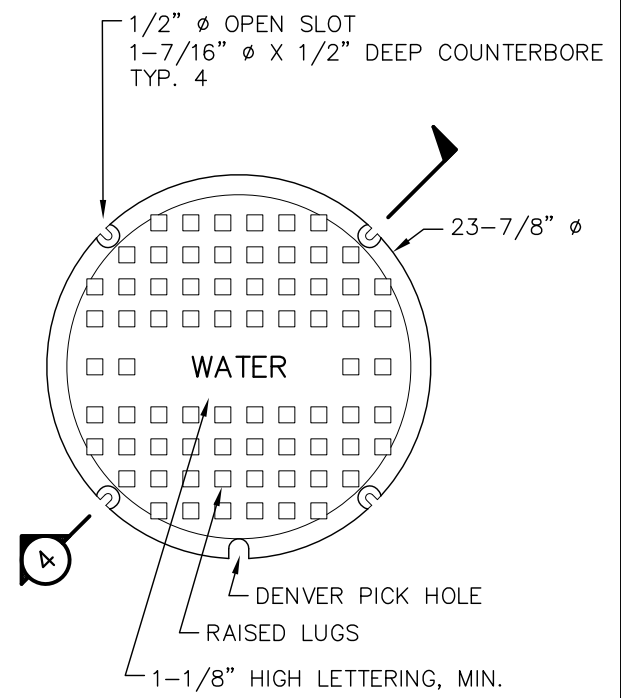
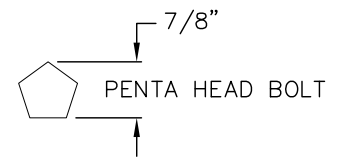
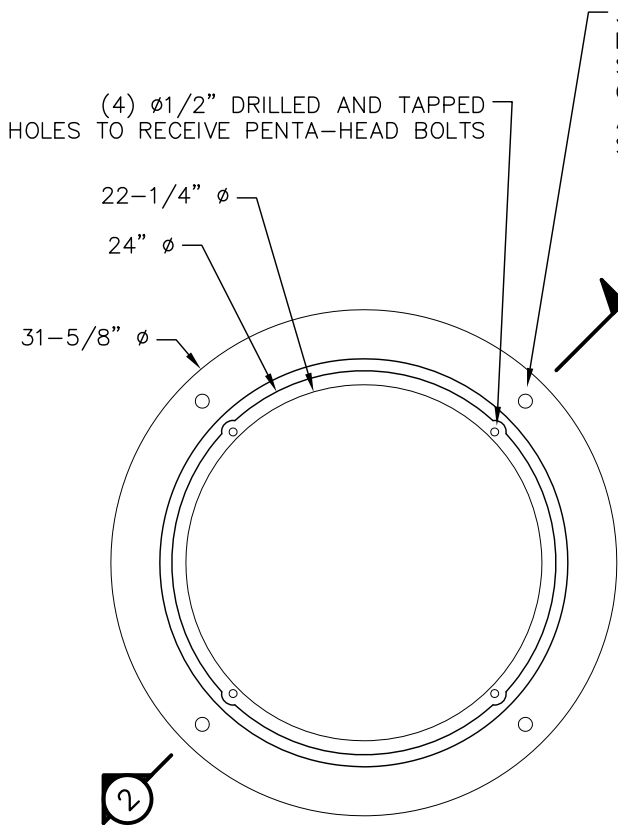

1 SECURE/FLOODPROOF RING PLAN
1" = 1'

3 SECURE/FLOODPROOF COVER PLAN
1" = 1'

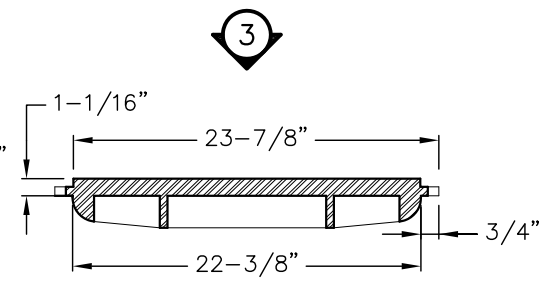
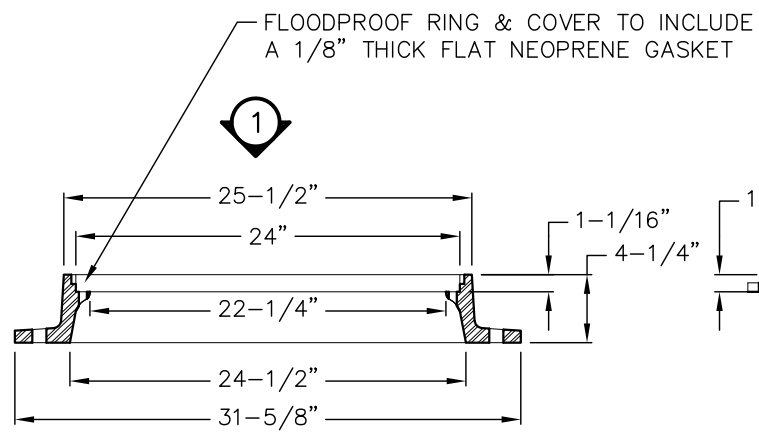

2 SECURE/FLOODPROOF RING SECTION
1" = 1'

4 SECURE/FLOODPROOF COVER SECTION
1" = 1'



WOODMOOR
WATER & SANITATION DISTRICT NO. 1

LOCKDOWN WATER RING & COVER
WATER UTILITY STRUCTURES
THIS CONSTRUCTION DETAIL SHOWS GENERAL CONFORMANCE TO SYSTEM SPECIFICATIONS AND MAY NEED TO BE ADJUSTED FOR SPECIFIC APPLICATIONS.

W-18
33 19 00
MAY 13, 2014

APPENDIX C

SUPPLEMENTAL INFORMATION

1. COMMERCIAL TAP APPLICATION, SERVICE LINE SIZING, AND FORMS
2. WATER AND SEWER SERVICE LINE MATERIAL, METERS, AND MINIMUM REQUIRED EQUIPMENT



STANDARD/MODIFIED TAP PERMIT FOR COMMERCIAL STRUCTURES

1. PERMITTED PREMESIS/PERMITTED SIZE(S):

Street address: _____ Monument, CO 80132

Legal Description: Lot # _____, Block # _____, Subdivision _____.

Taps permitted to be installed (circle all that apply): Water Sewer Fire Suppression

Sewer tap size: _____ (Inches) Water tap size: _____(Inches)

Water tap size (Fire Suppression)_____ (inches)

Total Drainage Fixture Units (domestic)_____ Total Water Supply Fixture Units (domestic):_____

Water Meter Size (domestic)_____

Water Meter Size (irrigation)_____

2. PERMIT CONTACT INFORMATION:

Name of Prime Contractor

Name of Owner

Mailing Address

Mailing Address

City, State, Zip Code

City, State, Zip Code

3. PERMIT FEES PAID:

Application Deposit (refundable): _____, Equipment Fee: _____,

Processing / Inspection Fee: _____,

Tap Fees: Water: Service Line & Tap Size: _____, Fee: _____,

 Sewer: Drainage Fixture Units: _____, Fee: _____,

Total Fees and Deposit: _____.

4. GENERAL PERMIT TERMS AND CONDITIONS:

- a. Owner agrees to pay the water and sewer monthly fees and abide by the rules, regulations and policies of the District as may be amended from time to time. A copy of these rules and regulations are available for inspection at the District office.
- b. Installation of taps, service lines and associated equipment shall be in accordance with all District rules and regulations and system specifications and shall adhere to and be in compliance with the service line plan as approved by the District.
- c. Owner shall be responsible for calling and scheduling inspections of the tap and service line installations as well as the meter and associated equipment installations prior to covering up any work. Partial inspections may be requested as the work commences. Once all tap, service line, meter and associated service equipment has been installed and has passed inspected by the District (final inspection), the District will install the meter register(s) necessary to read water usage.
- d. If construction is not completed and final inspection by the District is not made within 12-months from the date this permit is issued, the permitted premises will be subject to any increase in tap fees that takes effect prior to the time that final inspection is made. If a tap has not been made within the 12-month period, no tap will be allowed until any applicable increase in tap fees has been paid. Any tap fee prepaid prior to March 15, 1995, is not affected by this provision.
- e. A water hammer arrester and a pressure reducing valve that complies with District system specifications must be installed before each water meter. An approved cross connection control device must be installed after each water meter and at each fire suppression service line entry into the building. The cost of installation, maintenance and testing in accordance with the Districts rules and regulations shall be the responsibility of the property owner.
- f. Commercial meters newly installed are owned and maintained by the District. Owner shall be liable to the District for any damages to or loss of a meter caused by Owner.
- g. Exclusive of the water curb stop box, the water service line from the main to the Owners property line or curb box, whichever is closer to the water main, is owned and maintained by the District. Owner shall be liable to the District for any damages or obstructions to this reach of service line caused by Owner.
- h. The Woodmoor Water and Sanitation District No. 1 is not responsible for any cost of installation, operation or maintenance of any private water service lines or sewer service lines.
- i. The owner is responsible for contacting the District for water/sewer main locates.
- j. After the water tap is completed, the District will charge the minimum monthly water and sewer service fees as well as any other applicable fees. A meter reading will be taken by the District as of occupancy date, and the District will continue to read the meter and provide the occupant this reading on the monthly bill. The District has increasing block rates to discourage excessive water use.
- k. Owner shall be responsible for verifying that a final inspection has been performed by the District prior to any request and subsequent issuance of a certificate of occupancy (CO) or temporary certificate of occupancy (TCO) by the regional building department or building authority having jurisdiction. If a CO/TCO is issued prior to the District conducting a final inspection and the installation of the water meter register(s), no refund of the tap fee deposit will be made and the District may disconnect service.

1. This permit shall transfer ownership upon sale of the property. Water and sewer fees and charges also run with the property rather than the person. The owner understands and agrees that the District will bill the tenant as a matter of courtesy to owner, however, if the tenant does not pay, the owner of the property is responsible for payment of any outstanding bills.

m. Site Specific Provisions:

COMMERCIAL TAP P E R M I T

Approved this ____ day of _____, 20__.

WOODMOOR WATER AND SANITATION DISTRICT NO. 1

By _____
For secretary

This Permit Form is effective the _____ day of _____, 20____ and supersedes all previous permits issued by this District for the premises.



WOODMOOR
Water & Sanitation District No. 1

**Commercial Sewer Service Line Sizing
Application & Forms for New or Modified Service**

Commercial Sewer SERVICE LINE (Tap) Sizing Review Process

Woodmoor Water and Sanitation District (the "District") accepts one method for sizing sewer service lines:

Standard Method

1. The Property Owner (or his assigned representative) shall be responsible for the accuracy of all data calculated and sent to the District for review.
2. The Owner works with an Architect/Professional Engineer to provide the necessary documentation for sewer service line sizing. (One form per building structure)
3. The Owner submits the Architect/Professional Engineer's completed domestic drainage fixture unit counts in accordance with International Plumbing Code (IPC) showing number of drainage fixture units and anticipated peak drainage flows for domestic drainage through the service line and into the sanitary sewer collection system. Estimated peak flows are used for design of tap & service line size. The Owner shall also submit one set of utility service line plans in accordance with the Districts "System Specifications" and one set of the proposed building's architectural Plumbing plans showing the drainage fixtures and piping layouts. Sample forms for drainage fixture unit counts are contained on page 4 of this document.
4. The District will review the proposed sewer service line sizing documents in conjunction with the water meter sizing documents (if applicable). The District will coordinate any comments/revisions with the Owner. Submittal will be reviewed within 21 calendar days.
5. If approved, the District will notify the Owner/design professional that the tap permit is available for pick up upon payment of all permit fees.



Commercial Sewer Service Line & Tap Size Application (New & Modified Service):

All landowners relevant to this application must be included as applicants of this submittal. By signing this application and attaching a completed Statement of Authority, applicant and property owner attests that they are aware of this application and agree to its content.

The Owner/Applicant shall attach the sewer line sizing documentation along with one set of drawings of the proposed plumbing mechanical plans for the structure to the Woodmoor Water and Sanitation District No. 1, (719) 488-2525, at 1845 Woodmoor Drive, Monument, CO 80132.

Sizing sewer service lines shall be based upon Drainage Fixture Units per the current approved version of the International Plumbing Code as adopted by the Pikes Peak Regional Building Department.

Owner/Applicant Name _____

Phone Number _____

Address of Facility _____

Use of Facility _____

Contractor information

The undersigned hereby makes application to Woodmoor Water and Sanitation District No. 1 for approval of sewer service size(s). Applicant has read and understands the application instructions, and certifies that all information contained herein is accurate and true to the best of their knowledge and belief.

Owner/Agent Signature

Date

EXAMPLE DRAINAGE FIXTURE UNIT WORKSHEET

Fixture Type	Number of Fixture units			Total Number of Fixture Units	Total d.f.u.
	Existing	+	Proposed		
(Common Fixtures listed below)					
		+		=	X
Automatic Cloths Washer, Commercial		+		=	X
Automatic Cloths Washer, Residential		+		=	X
Water Closet, 1.6 g.p.f.		+		=	X
Water Closet, >1.6 g.p.f.		+		=	X
Bathtub		+		=	X
Bidget		+		=	X
Combination Sink & Tray		+		=	X
Dental Lavatory		+		=	X
Dental Unit or Cuspidor		+		=	X
Dishwashing Machine, Domestic		+		=	X
Drinking Fountain		+		=	X
Emergency Floor Drain		+		=	X
Floor Drain		+		=	X
Floor Sink		+		=	X
Kitchen Sink, Domestic		+		=	X
Kitchen Sink, Domestic w/grinder		+		=	X
Laundry Tray (1 or 2 compartment)		+		=	X
Lavatory		+		=	X
Shower:					
	5.7 gpm or less	+		=	X
	>5.7<12.3 gpm	+		=	X
	>12.3<25.8 gpm	+		=	X
	>25.8<55.6 gpm	+		=	X
Service Sink		+		=	X
Sink		+		=	X
Urinal		+		=	X
Urinal, 1 gpf		+		=	X
Urinal, non-water supplied		+		=	X
Wash Sink		+		=	X
Water Closet		+		=	X
Other		+		=	X
Total Drainage Fixture Units (domestic) =					
Max Flow Rate (gpm) =					
Min Flow Rate (gpm) =					
Booster Pumps:					
Will Sewer Ejector Pump(s) be used?		Y	N		
If yes, please provide peak pumping system capacity (gpm) and information on any drainage fixture Units that will bypass the booster pump(s)					
Any process or special drainage use? (not included in above fixtures)		Y	N	Type	
if yes, type and peak gpm demand?					

Notes:

1) All listed fixtures from IPC Table 709.1, for fixtures not listed, refer to IPC.

I affirm that the information given is accurate and acknowledge that approval of meter size and maximum water capacity is based solely on the information provided above.

Owner/Agent: _____

Date: _____

Architect/Professional Engineer: _____

Date: _____

This sheet for District Internal use only:

Application received by _____ Date _____

New or Modified Service: New Modified

Existing:

Size of Tap & Service Line _____ Slope: _____ Material: _____

Total Drainage Fixture Units: _____

New or as Modified:

Size of Tap & Service Line _____ Slope: _____ Material: _____

Total Drainage Fixture Units: _____

Comments:



WOODMOOR
Water & Sanitation District No. 1

**Commercial Water Meter & Service Line Sizing
Application & Forms for New or Modified Service**

Commercial Water SERVICE LINE (Tap) Sizing Review Process

Woodmoor Water and Sanitation District (the “District”) accepts one method for **sizing water service lines**:

Standard Method

1. The Property Owner (or his assigned representative) shall be responsible for the accuracy of all data calculated and sent to the District for review.
2. The Owner works with the Architect/Professional Engineer to provide the necessary documentation for water service line sizing. (One form per building structure)
3. The Owner submits the Architect/Professional Engineer’s completed irrigation flow and domestic fixture unit counts in accordance with International Plumbing Code (IPC) showing number of fixture units and anticipated peak demands for irrigation and internal domestic water usage. Combined estimated peak flows (irrigation plus domestic) are used for tap & service line size selection per table 1 or 2 on page 8. The Owner shall also submit one set of utility service line plans in accordance with the Districts “System Specifications” and one set of the proposed building’s architectural Plumbing and Irrigation plans showing the water fixtures and piping layouts. Sample forms for fixture unit counts and irrigation system flows are contained in pages 6 and 7 of this document.
4. The District will review the proposed water service line sizing documents in conjunction with the water meter sizing documents. The District will coordinate any comments/revisions with the Owner. Submittal will be reviewed within 21 calendar days.
5. If approved, the District will notify the Owner that the tap permit is available for pick up upon payment of all permit fees.

Commercial Water METER Sizing Review Process

Woodmoor Water and Sanitation District (the “District”) accepts two methods for sizing water meters:

Standard Method

1. The Property Owner (or his assigned representative) shall be responsible for the accuracy of all data calculated and sent to the District for review.
2. The Owner works with the Architect/Professional Engineer to provide the necessary documentation for water meter sizing. (One form per building structure)
3. The Owner submits the Architect/Professional Engineer’s completed irrigation flow and domestic fixture unit counts in accordance with International Plumbing Code (IPC) showing number of fixture units and anticipated minimum and maximum demands for irrigation and internal domestic water usage. Meters for irrigation and internal domestic usage shall be separate and estimated peak flows are used for meter size selection per table 3 on page 7. The Owner shall also submit one set of utility service line plans in accordance with the Districts “System Specifications” and one set of the proposed building’s architectural Plumbing and Irrigation plans showing the water fixtures and piping layouts. Sample forms for fixture unit counts and irrigation system flows are contained in pages 5 and 6 of this document.
5. The District will review the proposed water meter sizing documents in conjunction with the service line sizing documents. The District will coordinate any comments/revisions with the Owner. Submittal will be reviewed within 21 calendar days.
6. If approved, the District will notify the Owner that the tap permit is available for pick up upon payment of all permit fees.
7. The Owner/Applicant is responsible for the cost of the water meter and related equipment.

Alternate Method

1. The Property Owner (or his assigned representative) shall be responsible for the accuracy of all data calculated and sent to the District for review.
2. An alternate engineered design for water meters may be submitted to the District, for consideration.
3. A registered design professional (architect or engineer) can submit sufficient technical data to substantiate an alternate design for water meter sizing. This data shall include, but not limited to, construction documents and calculations, to support the proposed alternate design of the water meter, for review and approval by the District. If a diversity factor is used in calculating the meter and service line size, then the engineer shall submit documentation justifying the diversity factor criteria.
4. The District will review the proposed water meter sizing documents. The District will coordinate any comments/revisions with the registered design professional. Submittal will be reviewed within 21 calendar days. If the alternative engineered design is not approved, a District representative shall notify the designer and request that the standard method be used.
4. If approved, the District will notify the Owner that the tap permit is available for pick up upon payment of all permit fees.
5. The Owner/Applicant is responsible for the cost of the water meter and related equipment.



Commercial Water Service Line, Tap & Meter Size Application (New & Modified Service):

All landowners relevant to this application must be included as applicants of this submittal. By signing this application and attaching a completed Statement of Authority, applicant and property owner attests that they are aware of this application and agree to its content.

The Owner/Applicant shall attach the water meter sizing documentation along with one set of drawings of the proposed water/plumbing mechanical plans for the structure to the Woodmoor Water and Sanitation District No. 1, (719) 488-2525, at 1845 Woodmoor Drive, Monument, CO 80132.

Sizing water meters shall be based upon Water Supply Fixture Units per the current approved version of the International Plumbing Code as adopted by the Pikes Peak Regional Building Department.

Owner/Applicant Name _____

Phone Number _____

Address of Facility _____

Legal Description Lot____, Block____, Subdivision_____, Filing____

Name of Prime Contractor (if known) _____

Address _____

Phone Number _____

Use of Facility _____

(restaurant, retail, school, office, etc.)

(Denote Answer)

Domestic Use Only: Y N

Irrigation Use Only: Y N

Combined Domestic/Irrigation: Y N

The undersigned hereby makes application to Woodmoor Water and Sanitation District No. 1 for approval of new or modified water tap and service size and meter size(s) requested per the attached documents. Applicant has read and understands the application instructions, and certifies that all information contained herein is accurate and true to the best of their knowledge and belief.

Owner/Applicant Signature

Date



Commercial Irrigation Demand Worksheet

Please choose method

Actual Demand Method (AD)

Design Criteria Method (DC)*

Example (AD)

(AD) Example illustrates a 3-zone system with zones A and B running simultaneously and C independently. To determine peak GPM: zone A + B operating together yields demand of 40 GPM (30 + 10); zone C yields demand of 30 GPM. Meter is sized to largest demand of 40 GPM for system. Appropriate meter size is 1-inch.

Zone	# Heads	GPM per Head	Total GPM per Zone
A	30	1	30
B	20	0.5	10
C	20	1.5	30
Totals	70		70

Example: Zone A + Zone B + Zone ____ = 30 GPM + 10 GPM + ____ GPM = 40 GPM Peak Irrigation System Demand

For AD Method, please provide requested information in table below

For DC Method, enter Value for maximum flow rate in box below

Zone	# Heads	GPM per Head	Total GPM per Zone

Determine maximum flow rate (GPM) by identifying which zones will be operating together ~or~ enter Design Criteria maximum flow rate (GPM)

Zone ____ + Zone ____ + Zone ____ = ____ GPM + ____ GPM + ____ GPM = _____ GPM Peak Irrigation Demand

AD **DC ***

** By selecting the Design Criteria Method (DC) for Irrigation Demand reporting, Owner/Applicant agrees to have empowered the Applicant (if other) to submit the information on their behalf and to the accuracy of the irrigation peak demand value reported herein. The DC peak demand value will be used in lieu of Approved Final Irrigation Plan submittal for the purposes of this form.*

Determine minimum flow rate (GPM) by identifying which zones will be operating together.

Zone ____ + Zone ____ + Zone ____ = ____ GPM + ____ GPM + ____ GPM = _____ GPM Min. Irrigation Demand

I affirm that the information given is accurate and acknowledge that approval of meter size and maximum water capacity is based solely on the information provided above, and such determination is at the sole discretion of Colorado Springs Utilities.

Owner/Applicant: _____ Date: _____

Architect/Professional Engineer: _____ Date: _____

EXAMPLE WATER SUPPLY FIXTURE UNIT WORKSHEET

Fixture Type (Common Fixtures Listed below)	Occupancy	Control Type	Number of Fixtures		=	Total Number of Fixtures	x	Hot + Cold IPC Load Value	=	Total w.s.f.u.	
			Existing	+ Proposed							
			+	=		x	=				
Bathroom Group	Private	Flush Tank	+	=		x	=				
Bathroom Group	Private	Flush Valve	+	=		x	=				
Bathtub	Private	Faucet	+	=		x	=				
Bathtub	Public	Faucet	+	=		x	=				
Bidjet	Private	Faucet	+	=		x	=				
Combined Fixture	Private	Faucet	+	=		x	=				
Dishwashing Machine	Private	Automatic	+	=		x	=				
Drinking Fountain	Offices, etc.	3/8" valve	+	=		x	=				
Kitchen Sink	Private	Faucet	+	=		x	=				
Kitchen Sink	Hotel, Restaurant	Faucet	+	=		x	=				
Laundry Trays (1 to 3)	Private	Faucet	+	=		x	=				
Lavatory	Private	Faucet	+	=		x	=				
Lavatory	Public	Faucet	+	=		x	=				
Service Sink	Offices, etc.	Faucet	+	=		x	=				
Shower Head	Public	Mixing Valve	+	=		x	=				
Shower Head	Private	Mixing Valve	+	=		x	=				
Urinal	Public	1" Flush Valve	+	=		x	=				
Urinal	Public	3/4" Flush Valve	+	=		x	=				
Urinal	Public	Flush Tank	+	=		x	=				
Washing Maching (8 lb.)	Private	Automatic	+	=		x	=				
Washing Maching (8 lb.)	Public	Automatic	+	=		x	=				
Washing Maching (15 lb.)	Public	Automatic	+	=		x	=				
water closet	Private	Flush Valve	+	=		x	=				
water closet	Private	Flush Tank	+	=		x	=				
water closet	Public	Flush Valve	+	=		x	=				
water closet	Public or Private	Flush Tank	+	=		x	=				
Other			+	=		x	=				
Other			+	=		x	=				
Other			+	=		x	=				
Other			+	=		x	=				
Other			+	=		x	=				
Total Water Supply Fixture Units (domestic) =											
Max Flow Rate (gpm) =											
Min Flow Rate (gpm) =											
Booster Pumps:						Max Capacity (gpm)	Min Capacity (gpm)				
Will Booster Pump(s) be used for the domestic system?						Y	N				
If yes, please provide peak pumping system capacity (gpm) and information on any water fixtures that will bypass the booster pump(s)											
Any process water or special water use? (not included in above fixtures)						Y	N	Type	Max Capacity (gpm)	Min Capacity (gpm)	
if yes, type and peak gpm demand?											

Notes:

1) All listed fixture values from IPC Table 103.3(2), for fixtures not listed, loads should be assumed by comparing the fixture to one listed using water in similar quantities and at similar rates. If gpm demand is known use IPC Table 103.3(3).

I affirm that the information given is accurate and acknowledge that approval of meter size and maximum water capacity is based solely on the information provided above.

Owner/Agent: _____

Date: _____

Architect/Professional Engineer: _____

Date: _____

Table 1 - Tap & Service Size Selection Table Maximum Allowable Fixture Units for Various Lengths of Service Line

Service Length (Ft.)	50	100	150	200	250	300	350	400	450	500	550	600	650
3/4"	20	9	6	5	4	4	3	3	3	2	2	2	2
1"	93	47	30	21	14	12	10	9	8	7	7	6	6
1-1/2"	430	257	181	140	114	96	83	73	65	58	53	48	45
2"	743	743	580	482	410	361	322	291	265	243	224	208	194
2-1/2"	1341	1341	1111	875	732	639	575	529	491	454	424	399	377
3"	1953	1953	1953	1953	1696	1458	1281	1144	1036	949	877	818	767
4"	3701	3701	3701	3701	3701	3701	3701	3413	3115	2875	2676	2505	2356
6"	35516	35516	35516	35516	35516	35516	35516	35516	35516	35516	35516	35516	35516

Table 2 - Tap & Service Size Selection Table Maximum Allowable Water Flow Rate (gpm) for Various Lengths of Service Line

Service Length (Ft.)	50	100	150	200	250	300	350	400	450	500	550	600	650
3/4"	19	13	11	9	8	7	7	6	6	6	5	5	5
1"	41	29	23	20	17	16	14	13	13	12	11	11	10
1-1/2"	111	76	61	52	47	42	39	36	34	32	30	29	28
2"	170	170	141	121	107	97	89	83	78	74	70	67	64
2-1/2"	250	250	222	190	168	152	140	130	122	116	110	105	100
3"	320	320	320	320	291	264	243	226	212	200	190	181	174
4"	500	500	500	500	500	500	500	500	444	420	399	380	364
6"	1000	1000	1000	1000	1000	1000	1000	1000	1000	1000	1000	1000	1000

Notes (table 1 and table 2):

- (1) Max. Elevational Difference between main and meter is 20 feet
- (2) Tables incorporate friction losses from main to the meter only
- (3) Tables do not account for length or friction losses nor elevational head loss associated with internal building plumbing
- (4) Tables based on minimum available static pressure at the main of 60 psi.

Table 3 Water Meter Selection Table

Range of Flow	Min. (gpm)	Max. (gpm)
Disc Meters		
3/4"	0.125	25
1"	0.500	70
1-1/2"	1.250	120
2"	1.500	170
Compound Meters		
2"	0.5	200
3"	0.5	450
4"	0.75	1000
6"	0.75	2000

Commercial Water Meter & Service Line Sizing Form Demand Summary Sheet

Flow:

Irrigation Flow (I): Maximum Flow Rate: _____ (gpm)

Minimum Flow Rate: _____ (gpm)

Requested Meter Size for Irrigation = _____ Inch (from Table 3 on page 7)

Domestic Flow (D): Maximum water supply fixture units _____

Maximum Flow Rate: _____ (gpm)

Minimum Flow Rate: _____ (gpm)

Requested Meter Size for Domestic = _____ Inch (use table 3 on page 7)

*Domestic Max Flow Rate based on w.s.f.u. total of _____ (from page 6) plus your reported Process Water and/or
Booster Pump Capacity totaling _____ gpm.*

Total Irrigation plus Domestic: Maximum Flow Rate: I + D = _____ (gpm)

Service Line & Tap Size Requested: _____ Inch (use table 1 or 2 on page 7)

Length of Service Line (Main to Meter): _____ Feet

Status: Proposed New Proposed Modification

Note: Unless separate taps are to be purchased for irrigation and domestic services, service line & tap size shall be based on maximum combined flow (i.e. max irrigation flow + Max Domestic Flow). Meter sizes may be dissimilar between irrigation, domestic and water tap & service size, however in no event shall any meter size be greater than the tap & service line size.

Additional Customer Comments:

Owner/Agent: _____ Date: _____

This sheet for District Internal use only:

Application received by _____ Date _____

New or Modified Service: New Modified

Existing:

Size of meter Irrigation _____ Type: Disk Compound

Size of meter Domestic _____ Type: Disk Compound

Size of tap & service line _____ Total Water Supply Fixture Units: _____

New or as Modified:

Size of meter Irrigation _____ Type: Disk Compound

Size of meter Domestic _____ Type: Disk Compound

Size of tap & service line _____ Total Water Supply Fixture Units: _____

Comments:

WATER AND SEWER SERVICE LINE MATERIAL, METERS AND MINIMUM REQUIRED EQUIPMENT

PART 1 GENERAL

1.1 SUMMARY

- A. Section Includes
 - 1. Piping material, tapping saddles, corporation stops, curb stops & boxes, water and sewer service line material, fittings, anti-hammer devices, meters, ball valves, check valves and associated water and sewer service line accessories.

1.2 REFERENCES

- A. Referenced Standards
 - 1. ANSI B31.9-Building Service Piping
 - 2. NSF 61-Drinking Water System Components-Health Effects
 - 3. ASTM D1784 – Rigid Polyvinyl Chloride (PVC) Compounds and Chlorinated Polyvinyl Chloride (CPVC) Compounds
 - 4. ASTM D2321 – Practice for Underground Installation of Flexible Thermoplastic Sewer Pipe
 - 5. ASTM D3034 – TYPE PSM Poly (Vinyl Chloride) (PVC) Sewer Pipe and Fittings
 - 6. ASTM D3212 – Joints for Drain and Sewer Plastic Pipes Using Flexible Elastomeric Seals
 - 7. ASTM F477 – Elastomeric Seals (Gaskets) for Joining Plastic Pipe
 - 8. AWWA C509-Resilient Seated Gate Valves 3 in through 12 in NPS, for Water and Sewage Systems
 - 9. AWWA C515-Reduced-Wall, Resilient-Seated Gate Valves for Water Supply Service
 - 10. AWWA C504-Rubber Seated Butterfly Valves

1.3 ACTION SUBMITTALS

- A. For items specified as “or equal”, owner/contractor shall determine if the product being installed meets the minimum requirements specified herein and no product submittals are required by the District.
- B. For products without an “or equal” statement or that are listed herein with specific model or manufacturer’s numbers, only those products specifically listed shall be installed. Owner/contractor may submit product data on alternate materials desired that illustrates the product desired to be used meets or exceeds the specified products attributes in all respects for approval or rejection by the District prior to installation.

1.4 QUALITY ASSURANCE

- A. Perform Work in accordance with all applicable codes and regulations.

1.5 REGULATORY REQUIREMENTS

- A. Conform to all municipal codes and ordinances, laws, and regulations of the State.
- B. In case of apparent conflict, state and local requirements govern over these specifications.
- C. In absence of state and local regulations, International Plumbing Code applies.

1.6 DELIVERY, STORAGE, AND HANDLING

- A. Deliver, store, protect and handle products according to manufacturer's recommendations.
- B. Deliver and store valves and accessories in shipping containers with labeling in place in accordance with AWWA C509/515.
- C. Provide temporary end caps and closures on all fittings. Maintain in place until installation.
- D. Seal valve ends to prevent entry of foreign materials into valve body
- E. During loading, transporting, and unloading, exercise care to prevent damage to material.

PART 2 PRODUCTS (WATER SERVICE LINES)**2.1 SERVICE LINE PIPING & FITTINGS (2" AND SMALLER)**

- A. Manufacturer and Product
 1. Type "K" soft copper, coils or standard 10 and 20 foot lengths, Mueller Streamline Co, or equal. Copper or lead free brass fittings in accordance with NSF 61.
 2. PE 4710 SDR-9 200 psi HDPE, copper tubing size (CTS), continuous coil, JM Eagle or equal. Stainless steel stiffening inserts of sufficient strength at all connection points. HDPE service lines shall be upsized one nominal CTS from Type K Copper tubing such that the inner diameter (ID) is no less than Type K Copper ID. All HDPE service pipe must have washed pea gravel or squeegee bedding 3" below and 6" above, and tracerwire from saddle to foundation. Reference Woodmoor Water and Sanitation District System Specifications Section 33 11 00 for additional information.

- B. Water tubing: Buried, ASTM B88; FS WW-T-799, Type K soft (annealed); or FS WW-T-775
- C. Water tubing: Exposed or above grade, ASTM B88; Type L, hard drawn
- D. Flanges: Cast bronze, 150 psig, brazed joints, ANSI B16.24:
 - 1. Flange bolts and nuts: As specified for steel pipe
 - 2. Flange gaskets: As specified for steel pipe, except full face
 - 3. 1/16-inch-thick preformed neoprene gaskets

2.2 SERVICE LINE PIPING & FITTINGS (2-1/2" AND 3")

- A. Manufacturer and Product
 - 1. Type "K" soft copper, Mueller Streamline Co, or equal. Copper or lead free brass fittings in accordance with NSF 61.
 - 2. PVC pipe, gasketed bell and spigot, ASTM D2241, IPS size, SDR 21 with 200 psi working pressure rating, JM Eagle "IPS Pressure" pipe or equal.
 - 3. Ductile Iron gasketed push on fittings (i.e. PVC ends), IPS size, ASTM A536, AWWA C153, 250 psi pressure rated, Harrington Corporation or equal. All fittings and valves must be restrained using ductile iron fitting restraints, Harrington Corporation Ductile Iron IPS restraints or equal.
 - 4. Ductile Iron or PVC pipe material and fittings in accordance with section 33 11 00 Water Utility Distribution Piping.

2.3 SERVICE LINE PIPING & FITTINGS (4" AND LARGER)

- A. Manufacturer and Product
 - 1. Ductile Iron or PVC pipe material and fittings in accordance with section 33 11 00 Water Utility Distribution Piping.

2.4 GATE VALVES (2" THROUGH 12")

- A. Manufacturers:
 - 1. American AVK – Series 45 or 65
 - 2. American Flow Control – Series 2500
 - 3. Or equal.
- B. AWWA C515 or AWWA C509, minimum working pressure of 250 psi., ductile iron body, lead free, stainless steel stem, two O-ring stem seals, non-rising stem with square nut, single wedge fully encapsulated with EPDM rubber, resilient seat, mechanical joint ends, control rod, and extension box.
- C. Rotation: Open left (counter clockwise) with the word "OPEN" and an arrow indicating the direction to open cast on valve body.

2.5 ISOLATION VALVES (BALL)

- A. Manufacturers
 - 1. Nibco - T-595-CS-R-66-LL
 - 2. Velan V3P-1000
 - 3. Or accepted substitution.
- B. Description
 - 1. For use on 4 inch and smaller non-buried piping.
 - 2. Three-piece, carbon steel body, threaded ends, full port with blowout proof stem.
 - 3. 316 SS trim w/vented ball, certified to NSF 61.
 - 4. 300 lbs minimum working pressure rating.

2.6 ISOLATION VALVES (BUTTERFLY – OPEN ACCESS)

- A. Manufacturers
 - 1. Nibco
 - 2. Apollo
 - 3. Or equal
- B. Description
 - 1. For use as isolation valves on 3 inch and larger non buried piping.
 - 2. 200 lbs minimum working pressure rating.
 - 3. Lead free, certified to NSF 61

2.7 TAPPING SADDLES

- A. Manufacturers and Products
 - 1. Romac Stainless Steel Repair Clamp with Tapping Saddle.
 - 2. PowerSeal Model 3450AS Stainless Steel SaddleCorp.
 - 3. Or accepted substitution.
- B. Description
 - 1. Stainless Steel.
 - 2. Minimum dual 304 stainless steel straps, washers, and nuts.
 - 3. Rubber seating gasket.
 - 4. 250 psi minimum pressure rating.
- C. No direct taps.

2.8 CORPORATION STOPS

- A. Manufacturer and Products (2" and smaller)
 - 1. Ford ball corporation valve, Model FB600-X- XX, AWWA taper inlet X Flare, Ford quick joint compression or pack outlet, 300 psi. working pressure.
 - 2. Mueller 300 ball corporation valve, AWWA taper X Flare, Mueller 110 compression or pack outlet, 300 psi. working pressure

3. Or accepted substitution.

2.9 CURB STOPS

- A. Manufacturers and Products (2" and smaller)
 1. Ford "B" Series Ball Curb Valve (Non Minneapolis style), Flare inlet X Flare, ford quick joint compression or pack outlet 300 psi. working pressure
 2. Mueller 300 Ball Curb Valve (Non Minneapolis style), Flare inlet X flare, Mueller 110 compression or pack outlet, 300 psi. working pressure
 3. Or accepted substitution.

2.10 CURB STOP BOXES (2" AND SMALLER CURB VALVES)

- A. Manufacturers and Products
 1. Tyler Union 6500 series, 3/4" through 1 1/2" curb valves: Arched style base, cast iron sections, slip or screw type extensions, with asphalt bituminous coating, 27/32" standard lid with pentagon head plug. For curb stop valves 2" in size, use "enlarged" box base.
 2. Or accepted substitution.

2.11 CURB STOP BOXES (2-1/2" AND LARGER GATE VALVES)

- A. Manufacturers and Products
 1. Tyler Union 6500 series, 3/4" through 1 1/2" curb valves: Arched style base, cast iron sections, slip or screw type extensions, with asphalt bituminous coating, 27/32" standard lid with pentagon head plug. For curb stop valves 2" in size, use "enlarged" box base.
 2. McDonald Manufacturing Co Arch Pattern with brass cotter pin and pentagon bolt lid with tracer wire terminal, 3/4" to 1" curb valves: Model 5607. For 1 1/2" to 2" curb valves: Model 5606.
 3. Or accepted substitution.
- B. Description
 1. Threaded type.
 2. Cast iron box, base, extensions, and lid.
 3. Minimum inside diameter 5 inches.
 4. Minimum wall thickness 3/16 inch.
 5. All parts coated by dipping in asphalt varnish.
 6. Minimum lid depth 3".
 7. Lid is drop type and marked with "WATER".

2.12 WATER METERS

- A. Manufacturers and Products
 1. Kamstrup Meters
 2. AquaCell End Points

- B. Supplied by District, size shall be as indicated on tap permit.

2.13 ANTI-HAMMER ARRESTORS

- A. Manufacturers and Products
 1. Precision Plumbing Products, Inc.
 2. Watts
 3. Or equal
- B. Metallic body, NSF 61 certification with 0-200 psi static pressure rating.
- C. Size and surge pressure rating: Per manufacturer's recommendations for specific pressure and flow application

2.14 BACKFLOW PREVENTION DEVICES

- A. Manufacturers and Products
 1. Watts
 2. Febco
 3. Or equal
- B. $\frac{3}{4}$ " Residential Configurations
 1. Copper or lead-free brass
 2. Two positive seating dual check modules
 3. Test cocks not required
 4. 150 psi. minimum working pressure rating
 5. One (1) supplied by District
 6. Larger than $\frac{3}{4}$ " residential application– See non health hazard configurations below
- C. Non-Health Hazard Configurations
 1. Copper or lead free brass
 2. AWWA C510
 3. Two positive seating check modules
 4. Minimum of three test cocks
 5. 150 psi. minimum working pressure rating
 6. Size: per tap permit
 7. Commercial application – supplied by Owner
- D. Health Hazard/Potential Health Hazard Configurations
 1. Copper or lead free brass
 2. AWWA C511
 3. Two positive seating check modules with internal pressure differential relief valve
 4. Minimum of three test cocks
 5. 150 psi. minimum working pressure rating

6. Size: per tap permit
7. Commercial application – supplied by Owner

2.15 PRESSURE REDUCING VALVES

- A. Manufacturers and Products
 1. Wilkins
 2. Watts
 3. Or equal
- B. Metallic body, NSF 61 certification
 1. Lead free
 2. 200 psi. minimum upstream working pressure rating
 3. Size: per tap permit
 4. Adjustable pressure range downstream : 0 psi. minimum to 75 psi. maximum. or if plumbing code requires more stringent standards, per plumbing code.

PART 3 PRODUCTS (SEWER SERVICE LINES)

3.1 SERVICE LINE PIPING & FITTINGS

- A. Products
 1. Cast Iron Soil Pipe, ASTM A74, extra heavy or service type, bell and spigot or plain end.
 2. Cast Iron Soil Pipe Fitting – ASTM C564 or CISPI Standard 310
 3. Plastic Pipe and fittings – ASTM D3034, type PSM, Poly Vinyl Chloride (PVC) material, bell and spigot or glue joint style, SDR 35, Schedule 40 or 80
- B. Sanitary Sewer Service Connection
 1. “In Line” Wye
 - a. Wye fitting with gasketed joint per Section 33 31 00.
 - b. Schedule
 - 1) For use when installing proposed service line connections to proposed mains. (New Construction)
 2. Saddle Tap
 - a. Manufacturer
 - 1) Geneco
 - 2) Or Accepted Substitution
 - b. Product
 - 1) Sealtite Multi Range Sewer Saddle
 - 2) Configuration: Wye or Tee
 - 3) Model:
 - a) Wye: Type E
 - b) Tee: Type U

- 4) Base: ASTM A-48 Class 30 Cast Iron dip-coated in water-based bituminous coating
 - 5) Gasket: O-Ring ASTM C-367-77 Tubular Polyisoprene
 - 6) PVC Adapter: ASTM D-3034 SDR-35 gasketed bell cemented to cast iron base with two-part urethane adhesive
 - 7) Strap: One or Two 24 gauge 2.5 inch wide Type 304 Stainless Steel
 - 8) Strap Pins: 0.75 inch diameter Type 303 Stainless Steel
 - 9) T-Bolts: 0.375 inch diameter-16 Type 304 Stainless Steel
 - 10) Nuts and Washers: Type 18-8 Stainless Steel
- c. Schedule
- 1) For use when connecting to existing mains.

3.2 TRACER WIRE

- A. Manufacturers and Products
1. Material: # 10 AWG copper clad steel, high strength with minimum 600 lb. break load.
 2. Coating: Minimum 30 mil HDPE insulation thickness for direct bury.
 3. Color: Blue
 4. Connectors: Moisture displacement and corrosion resistant connectors.
 - i. Copperhead Snakebite
 - ii. 3M DBR
 - iii. Or approved substitution
- B. Terminal Stations
1. Copperhead 2" two-terminal switchable lid, model SP-SWLID-*2 or approved substitution
 2. Color: Blue
 3. Text: WATER
 4. Installed at minimum every 500 feet along pipeline, and at all fire hydrants and water valves.
- C. Grounding
1. Magnesium anode, 1.5 pounds minimum, securely grounded and connected to terminal lid

PART 4 EXECUTION

4.1 INSTALLATION

- A. Install all components per manufacturers recommendations.
- B. All water and sewer service lines must be visible for inspection. Directional boring is not allowed on service lines. All service lines must be bedded per Section 31 00 00 in the Woodmoor Water and Sanitation District No 1 System Specifications.

- C. Install 1-1/2" plastic pipe insert, minimum 5 feet in length, into curb stop valve cans, centered on curb stop valve.
- D. For buried underground water service lines utilizing type K soft copper, use brass compression or flare fittings to connect/couple joints, no sweating, soldering or brazed connection permitted underground.
- E. For interior or non-buried copper, soldering, brazing and sweating of copper fittings is permitted in accordance with the local plumbing code.
- F. No backflow prevention device shall be installed in such a configuration that would allow for submergence of the device (i.e. non-draining underground vaults, non-draining basements below grade, etc.). All backflow prevention devices shall be installed at locations where the area in and around the installed device is free draining.

4.2 FIELD QUALITY CONTROL

- A. Service lines from (and including) the curb stop valve/service line shut off valve to the building are the property of the lot owner. Field quality control shall be as provided/mandated by International Plumbing Code or Owner. The District performs inspections on service lines and equipment only to verify location, proper configuration of mandatory components, size of service lines and associated appurtenances. The District does not assume any responsibility or liability for product or installation quality, integrity, or longevity of private system components. Manufactures and products for private system improvements and components listed herein are listed in general and/or generic format with minimum attributes that must be complied with.
- B. Service lines from the water main up to (but not including) the curb stop valve to the property are installed at the expense of owner but are owned and maintained by the District. Field quality control shall be as provided/mandated by International Plumbing Code or the District. The District performs inspections on this portion of service lines and equipment to verify location, material, proper configuration and installation of equipment and associated appurtenances. Products in this reach of service line(s) are specifically listed by manufacturer's part number and shall be used unless a substitute item is otherwise approved (in writing) by the District,

END OF SECTION

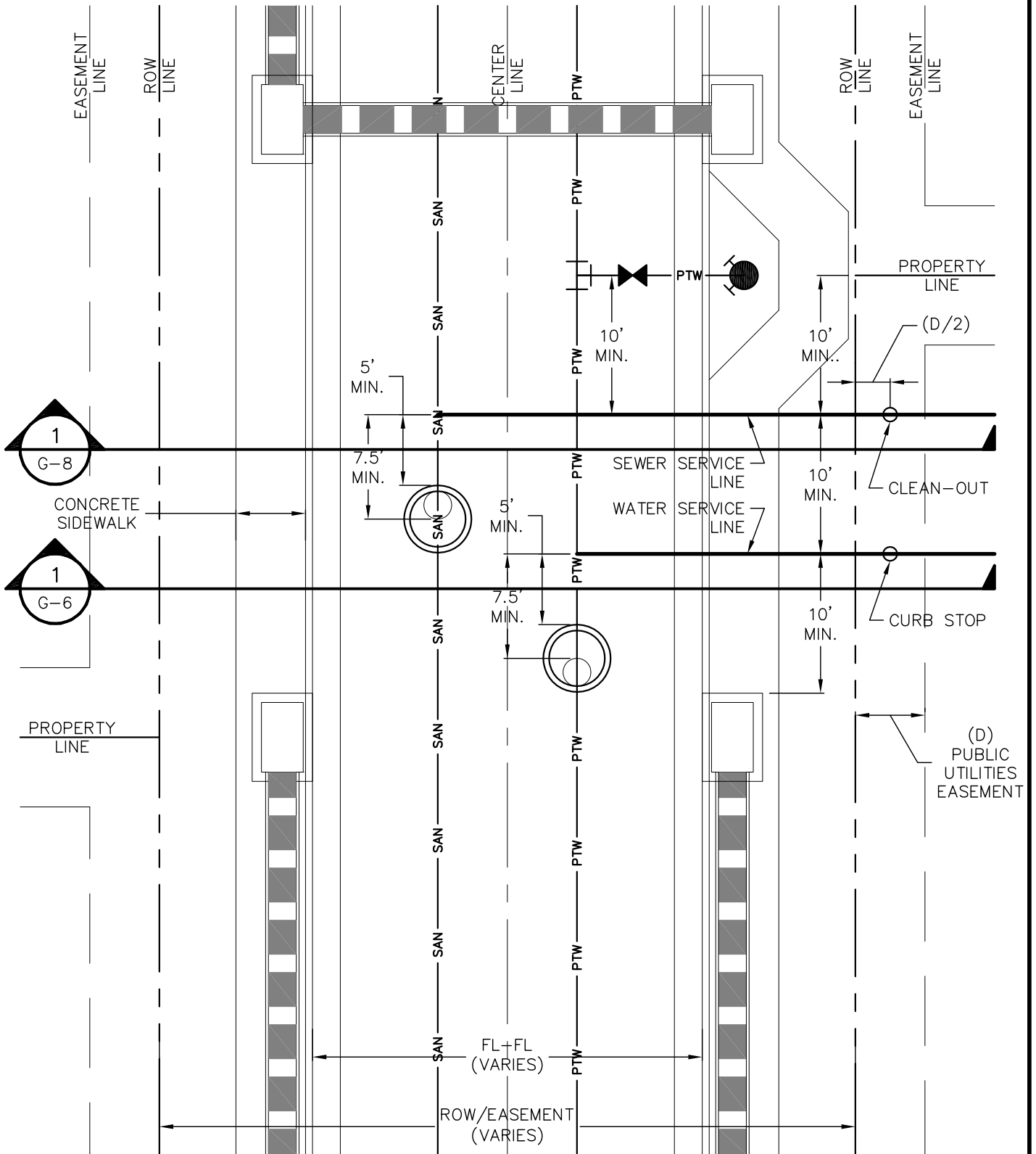

1 TYPICAL SERVICES LAYOUT (PLAN)
1"=10'



WOODMOOR
WATER & SANITATION DISTRICT NO. 1

TYPICAL SERVICES LAYOUT (PLAN)

GENERAL

THIS CONSTRUCTION DETAIL SHOWS GENERAL CONFORMANCE TO SYSTEM SPECIFICATIONS AND MAY NEED TO BE ADJUSTED FOR SPECIFIC APPLICATIONS.

G-5

-

MAY 13, 2014

REFER TO WATER & SEWER SERVICE LINE EQUIPMENT SPECIFICATIONS FOR SUPPLEMENTAL INFORMATION
(APP C OF THE SYSTEM SPECIFICATIONS)

GENERAL NOTES:

- PROVIDE METAL T-POST AT CURB STOP WHEN CONSTRUCTION OF STUB-OUT TO LOT IS COMPLETE. T-POST MAY BE REMOVED AFTER CONNECTION TO SERVICE STUB.
- SERVICE LINE MAY BE TYPE K COPPER OR APPROVED HDPE TUBING (33 11 00). ALL HDPE SERVICE LINES REQUIRE STIFFENING INSERTS AT ALL CONNECTION POINTS OF FITTINGS.

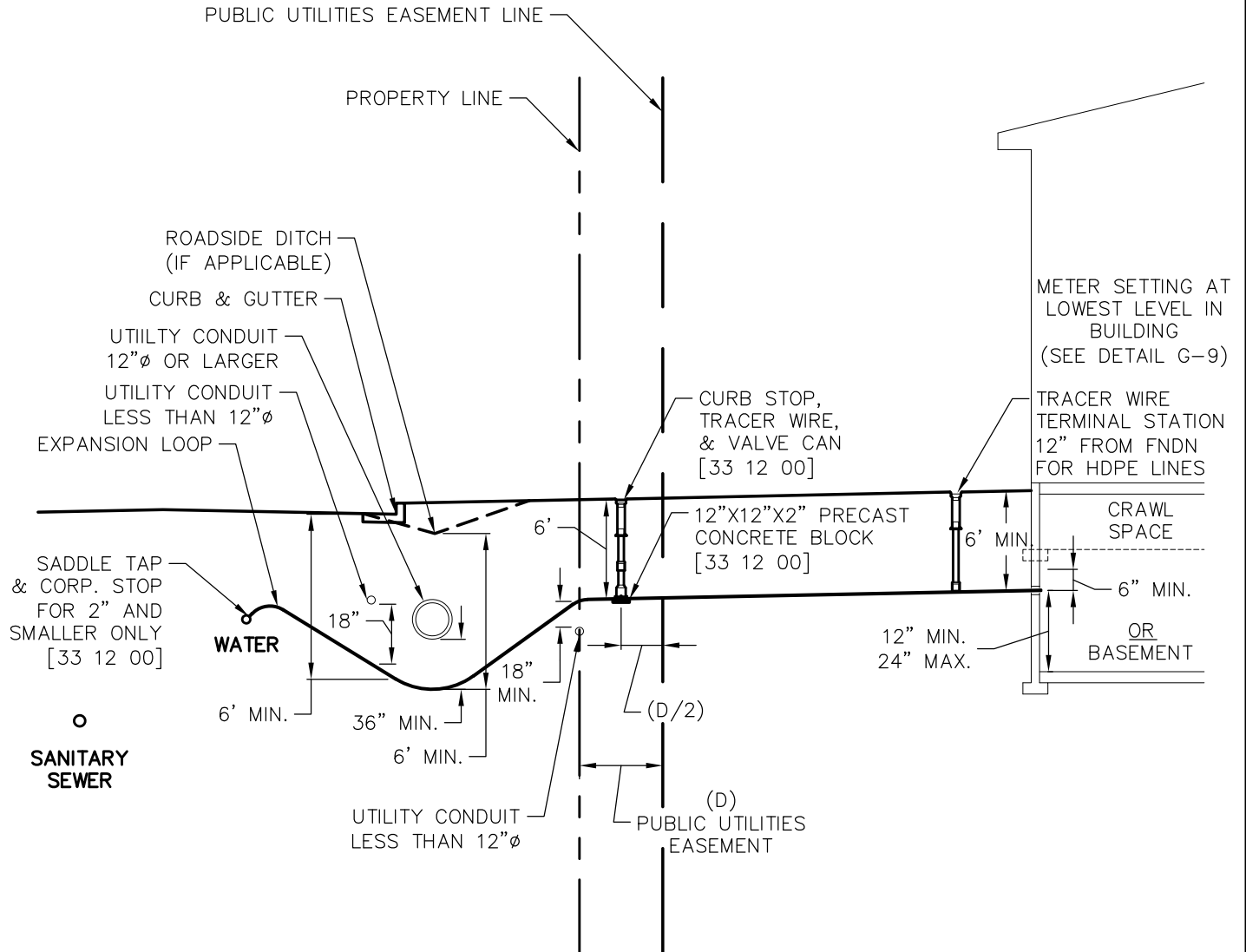

① **WATER SERVICE (3/4" TO 2")**
1"=10'

	WATER SERVICE (3/4" TO 2")	G-6
	GENERAL	-
	THIS CONSTRUCTION DETAIL SHOWS GENERAL CONFORMANCE TO SYSTEM SPECIFICATIONS AND MAY NEED TO BE ADJUSTED FOR SPECIFIC APPLICATIONS.	JAN 1, 2023

REFER TO WATER & SEWER SERVICE LINE EQUIPMENT SPECIFICATIONS FOR SUPPLEMENTAL INFORMATION
(APP C OF THE SYSTEM SPECIFICATIONS)

GENERAL NOTES:

– MECHANICAL JOINT RESTRAINTS REQUIRED ON ALL FITTINGS.

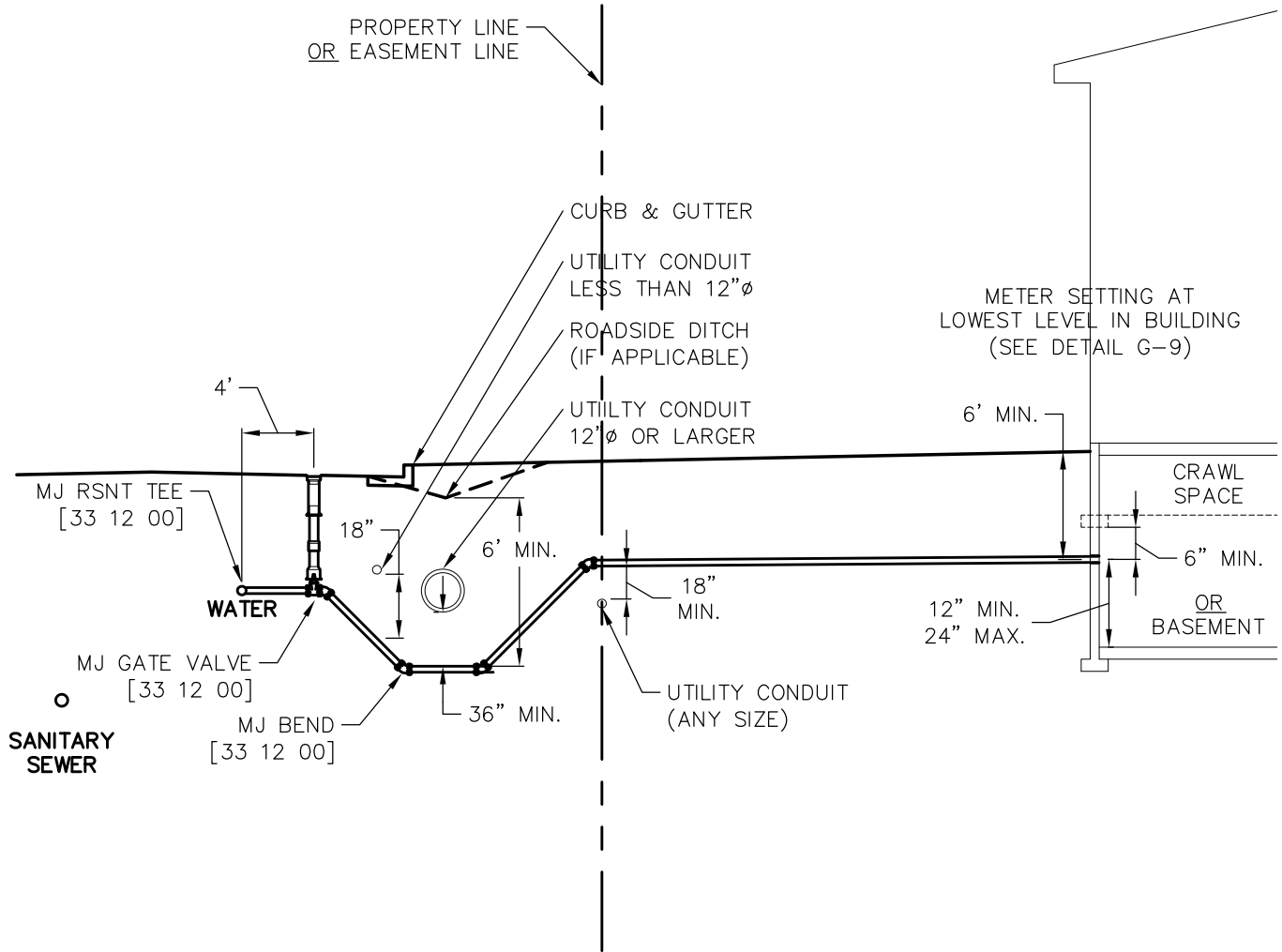

① WATER SERVICE (2-1/2" TO 6")
1"=10'

	WATER SERVICE (2-1/2" TO 6")	G-7
	GENERAL	-
	<small>THIS CONSTRUCTION DETAIL SHOWS GENERAL CONFORMANCE TO SYSTEM SPECIFICATIONS AND MAY NEED TO BE ADJUSTED FOR SPECIFIC APPLICATIONS.</small>	
		JAN 1, 2023

REFER TO WATER & SEWER SERVICE LINE EQUIPMENT SPECIFICATIONS FOR SUPPLEMENTAL INFORMATION
(APP C OF THE SYSTEM SPECIFICATIONS)

GENERAL NOTES:

- PROVIDE METAL T-POST AT CURB STOP WHEN CONSTRUCTION OF STUB-OUT TO LOT IS COMPLETE. T-POST MAY BE REMOVED AFTER CONNECTION TO SERVICE STUB.
- INTERMEDIATE CLEAN-OUT ASSEMBLIES REQUIRED AT 100' INTERVALS (FOR UNI-DIRECTIONAL) OR 200' INTERVALS (FOR BI-DIRECTIONAL) BETWEEN PROPERTY LINE CLEAN-OUT AND BUILDING CLEAN-OUT..

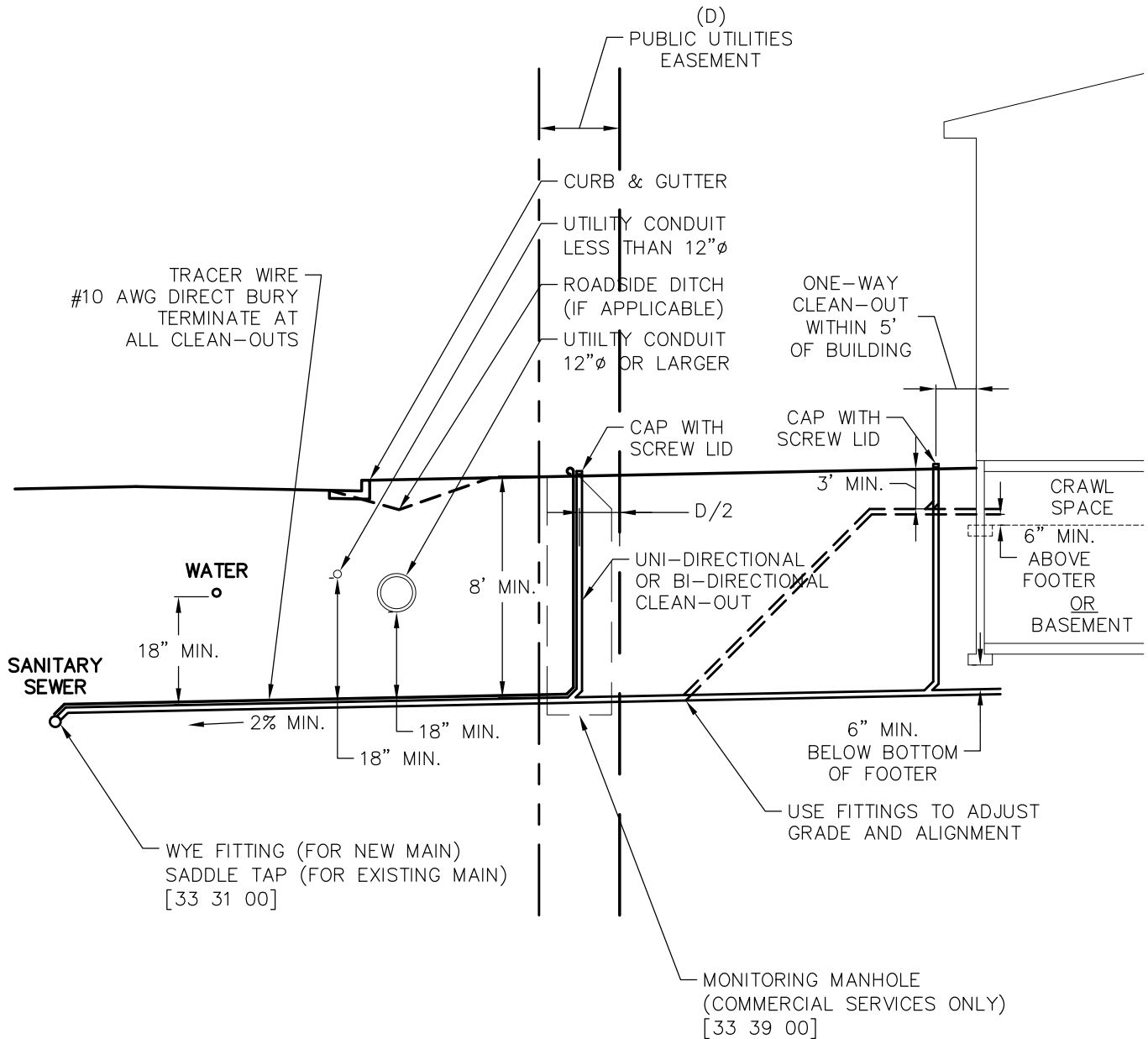

1 TYPICAL SEWER SERVICE (SECTION)
1"=10'

 WOODMOOR WATER & SANITATION DISTRICT NO. 1	TYPICAL SEWER SERVICE (SECTION)	G-8
	GENERAL	-
	THIS CONSTRUCTION DETAIL SHOWS GENERAL CONFORMANCE TO SYSTEM SPECIFICATIONS AND MAY NEED TO BE ADJUSTED FOR SPECIFIC APPLICATIONS.	JAN 1, 2023

REFER TO WATER & SEWER SERVICE LINE EQUIPMENT SPECIFICATIONS FOR SUPPLEMENTAL INFORMATION
(APPENDIX C OF THE SYSTEM SPECIFICATIONS)

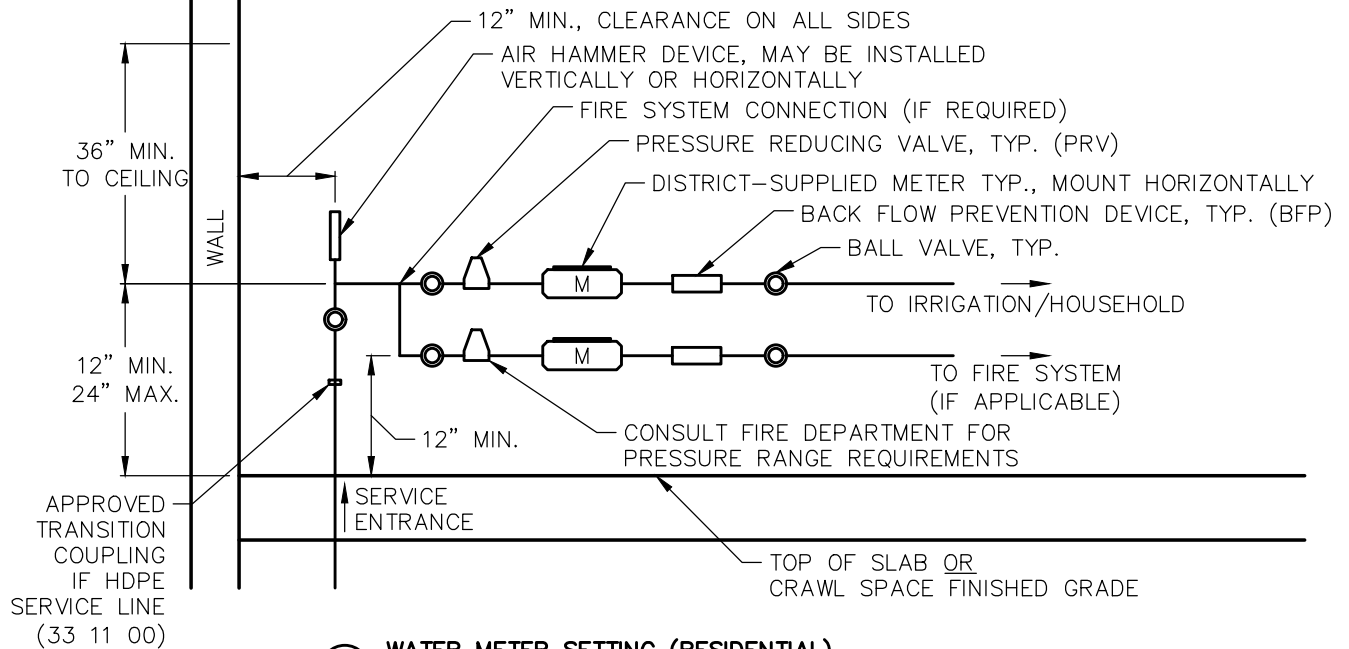

1 WATER METER SETTING (RESIDENTIAL)
NOT TO SCALE

NOTE: FOR ALL HDPE SERVICE TUBING, INSTALL TRANSITION COUPLINGS AND UNISTRUT PIPE SUPPORTS ON COPPER METER ASSEMBLY (33 11 00)

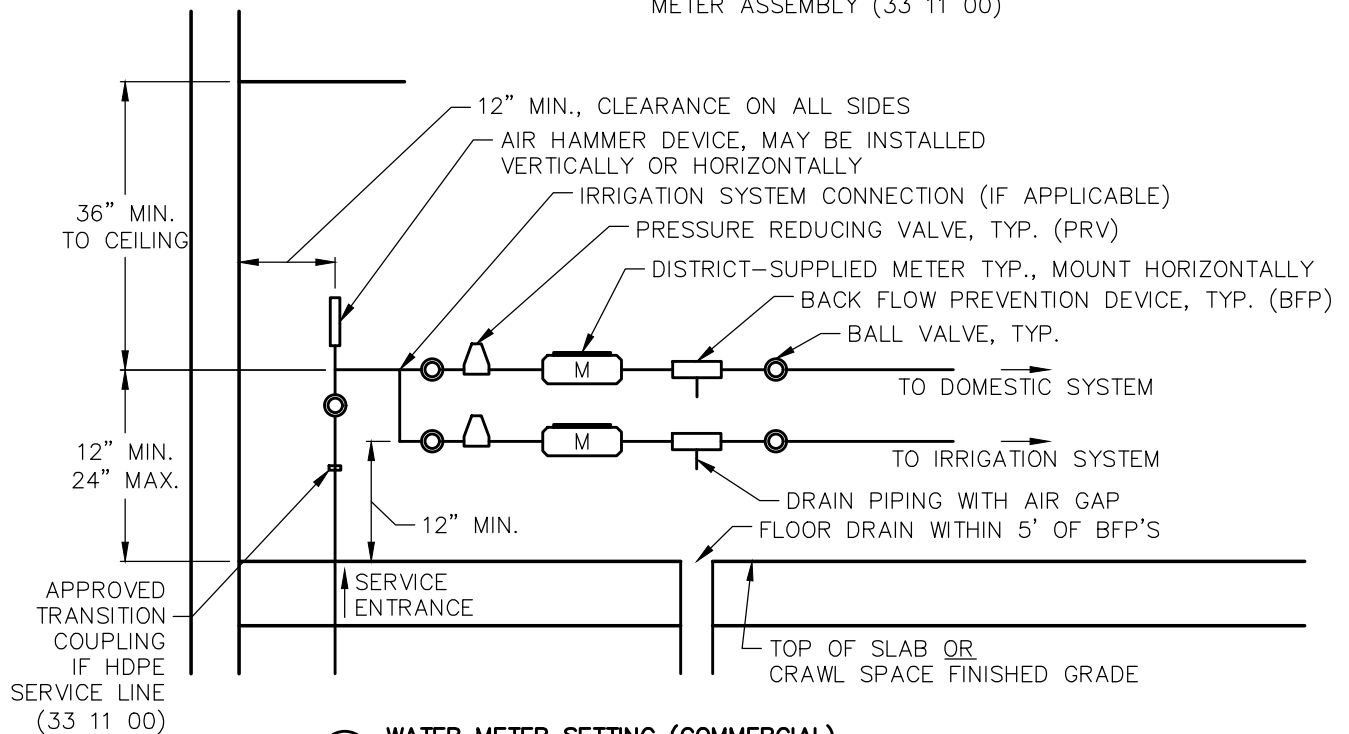

1 WATER METER SETTING (COMMERCIAL)
NOT TO SCALE



WATER METER SETTING DETAIL	G-9
GENERAL	-
THIS CONSTRUCTION DETAIL SHOWS GENERAL CONFORMANCE TO SYSTEM SPECIFICATIONS AND MAY NEED TO BE ADJUSTED FOR SPECIFIC APPLICATIONS.	
JUNE 6, 2023	

Woodmoor Water & Sanitation District Residential Water Service Installation

